

# Lecture 9: ROMs, PLAs and PALs, Oh My

---

CSE 370, Autumn 2007  
Benjamin Ylvisaker

---

## Where We Are

- Last lecture: Combinational Verilog
- This lecture: ROMs, PLAs and PALs, oh my
- Next lecture: Quine-McCluskey Minimization
- Homework 3 due Wednesday
- Read lab 3

# Discrete Gates are a Pain

- Building circuits with discrete chips, like what you've done in lab, is only tractable up to modestly sized circuits
- Alternatives:
  - ROMs
  - PLAs
  - PALs
  - FPGAs (later)

## Read-Only Memories

- Direct implementation of a truth table

A	B	C	F0	F1	F2	F3
0	0	0	1	0	1	1
0	0	1	0	0	0	1
0	1	0	0	0	1	0
0	1	1	1	1	1	1
1	0	0	0	1	1	1
1	0	1	1	0	0	0
1	1	0	1	1	0	0
1	1	1	0	1	0	1

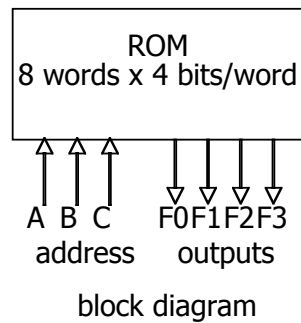

# ROM Implementation

- “words”
- “word-size”
- “address”

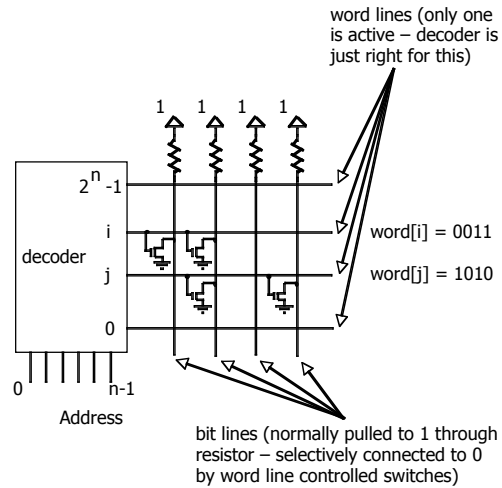

## ROM Pros and Cons

- Pros
  - Simple to use (just build a truth table for your functions)
  - Guaranteed to be able to implement any functions of a given number of inputs
- Cons
  - Large: Size is proportional to  $2^{\#}$  of inputs
  - Inefficient: can't exploit don't cares or “structure” of a function

# PLAs and PALs

- “Programmable Logic Array” and “Programmable Array Logic”

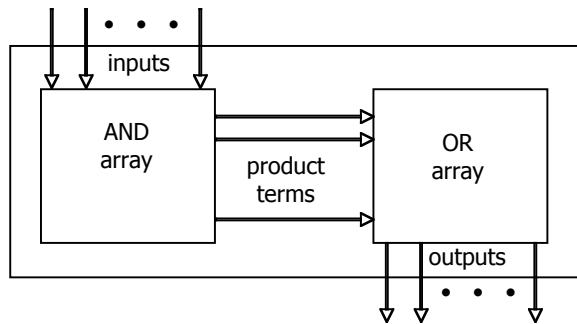

## Program with Wire Connections

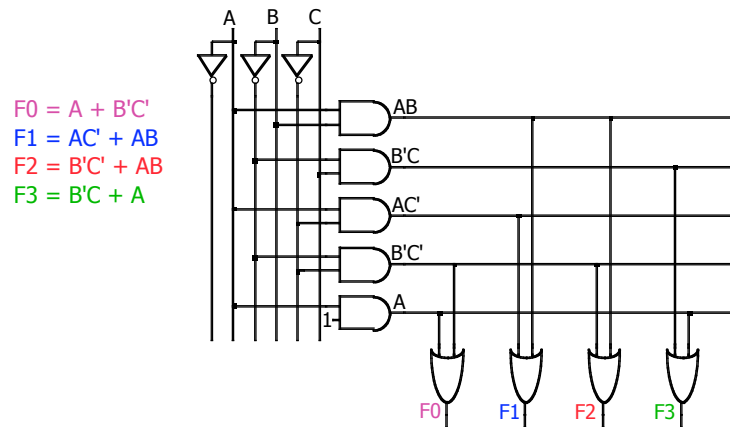

# Drawing PLA “Programs”

Before Programming

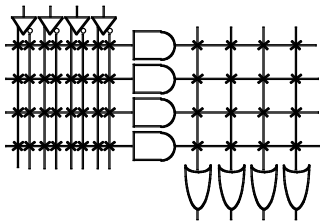

After Programming

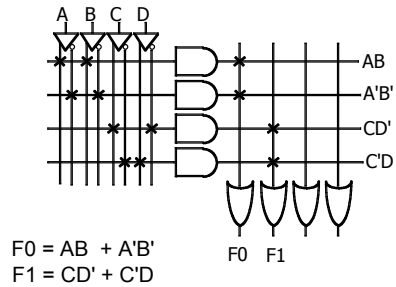

## Bigger PLA Example

- $F1 = ABC$
- $F2 = A + B + C$
- $F3 = A' B' C'$
- $F4 = A' + B' + C'$
- $F5 = A \text{ xor } B \text{ xor } C$
- $F6 = A \text{ xnor } B \text{ xnor } C$

A	B	C	F1	F2	F3	F4	F5	F6
0	0	0	0	0	1	1	0	0
0	0	1	0	1	0	1	1	1
0	1	0	0	1	0	1	1	1
0	1	1	0	1	0	1	0	0
1	0	0	0	1	0	1	1	1
1	0	1	0	1	0	1	0	0
1	1	0	0	1	0	1	0	0
1	1	1	1	1	0	0	1	1

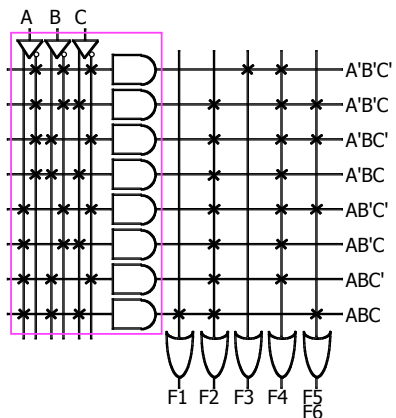

# The Difference Between PLAs and PALs

- PLAs
  - Programmable AND and OR
- PALs
  - Only programmable ANDs
  - ORs hard-wired

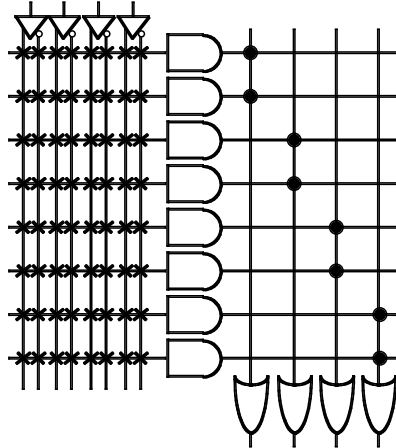

# BCD to SSD Converter

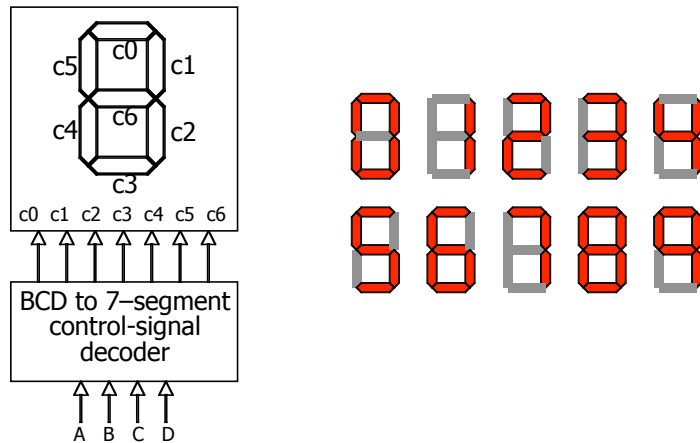

# BCD to SSD Truth Table

A	B	C	D	f0	f1	f2	f3	f4	f5	f6
0	0	0	0	1	1	1	1	1	1	0
0	0	0	1	0	1	1	0	0	0	0
0	0	1	0	1	1	0	1	1	0	1
0	0	1	1	1	1	1	1	0	0	1
0	1	0	0	0	1	1	0	0	1	1
0	1	0	1	1	0	1	1	0	1	1
0	1	1	0	1	0	1	1	1	1	1
0	1	1	1	1	1	1	0	0	0	0
1	0	0	0	1	1	1	1	1	1	1
1	0	0	1	1	1	1	0	0	1	1
1	0	1	-	-	-	-	-	-	-	-
1	1	-	-	-	-	-	-	-	-	-

## PLAs and PALs

- Pros
  - More efficient than ROMs for many “realistic” functions
  - Still quite flexible
- Cons
  - Cannot implement all functions of N inputs
  - Requires logic minimization for efficiency

# Additional PLA Features

- Feedback terms
  - Used to implement multi-level logic
- Registered outputs
  - Used to implement memory/sequential logic
- Tri-state outputs
  - Used to allow multiple circuits to share a single output wire (very carefully)

# Thank You for Your Attention

- Read lab 3
- Continue homework 3
- Continue reading the book