

# Hashing

CSE 373  
Data Structures

## Readings

---

- Reading
  - › Goodrich and Tamassia, Chapter 8

## The Need for Speed

---

- Data structures we have looked at so far
  - › Use comparison operations to find items
  - › Need  $O(\log N)$  time for Find and Insert
- In real world applications,  $N$  is typically between 100 and 100,000 (or more)
  - ›  $\log N$  is between 6.6 and 16.6
- Hash tables are an abstract data type designed for  $O(1)$  Find and Inserts

4/15/2004

CSE 373 - SP 04 -- Dictionaries  
and Hashing

3

## Fewer Functions Faster

---

- compare lists and stacks
  - › by reducing the flexibility of what we are allowed to do, we can increase the performance of the remaining operations
  - ›  $\text{insert}(L,X)$  into a list versus  $\text{push}(S,X)$  onto a stack
- compare trees and hash tables
  - › trees provide for known ordering of all elements
  - › hash tables just let you (quickly) find an element

4/15/2004

CSE 373 - SP 04 -- Dictionaries  
and Hashing

4

## Limited Set of Hash Operations

---

- For many applications, a limited set of operations is all that is needed
  - › Insert, Find, and Delete
  - › Note that no ordering of elements is implied
- For example, a compiler needs to maintain information about the symbols in a program
  - › user defined
  - › language keywords

4/15/2004

CSE 373 - SP 04 -- Dictionaries  
and Hashing

5

## Direct Address Tables

---

- Direct addressing using an array is very fast
- Assume
  - › keys are integers in the set  $U=\{0,1,\dots,m-1\}$
  - ›  $m$  is small
  - › no two elements have the same key
- Then just store each element at the array location `array[key]`
  - › search, insert, and delete are trivial

4/15/2004

CSE 373 - SP 04 -- Dictionaries  
and Hashing

6

# Direct Access Table

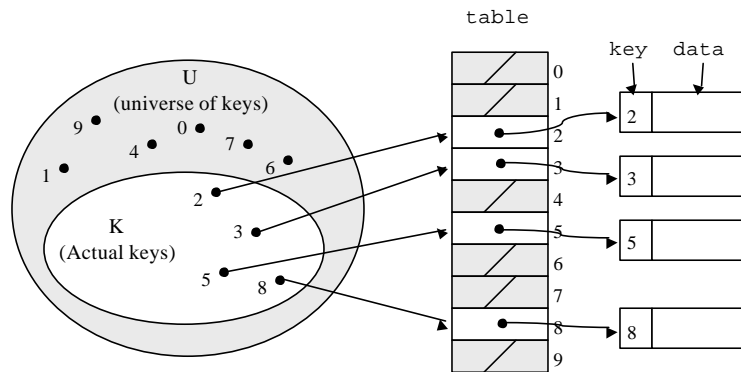

4/15/2004

CSE 373 - SP 04 -- Dictionaries  
and Hashing

7

# Direct Address Implementation

```
Delete(Table T, ElementType x)
    T[key[x]] = NULL    //key[x] is an
                        //integer

Insert(Table t, ElementType x)
    T[key[x]] = x

Find(Table t, Key k)
    return T[k]
```

4/15/2004

CSE 373 - SP 04 -- Dictionaries  
and Hashing

8

## An Issue

- If most keys in  $U$  are used
  - › direct addressing can work very well ( $m$  small)
- The largest possible key in  $U$ , say  $m$ , may be much larger than the number of elements actually stored ( $|U|$  much greater than  $|K|$ )
  - › the table is very sparse and wastes space
  - › in worst case, table too large to have in memory
- If most keys in  $U$  are not used
  - › need to map  $U$  to a smaller set closer in size to  $K$

4/15/2004

CSE 373 - SP 04 -- Dictionaries  
and Hashing

9

## Mapping the Keys

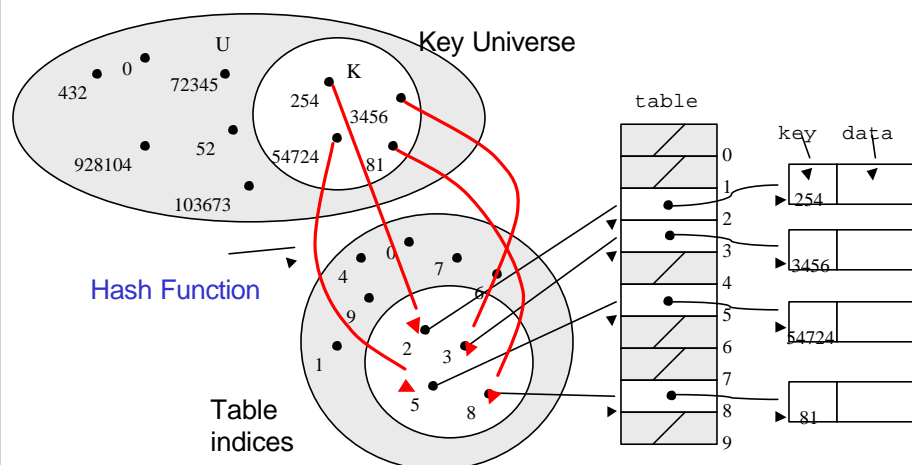

4/15/2004

CSE 373 - SP 04 -- Dictionaries  
and Hashing

10



## Go Directly to the Element

---

- What if we could directly index into the array using the **key**?
  - ›  $A[\text{"CSE 373"}] = \{\text{Size 85}\}$
- Main idea behind hash tables
  - › Use a key based on some aspect of the data to index directly into an array
  - ›  $O(1)$  time to access records

4/15/2004

CSE 373 - SP 04 -- Dictionaries  
and Hashing

13

## Indexing into Hash Table

---

- Need a fast **hash function** to convert the element key (string or number) to an integer (the **hash value**) (i.e, map from  $U$  to index)
  - › Then use this value to index into an array
  - ›  $\text{Hash}(\text{"CSE 373"}) = 157$ ,  $\text{Hash}(\text{"CSE 143"}) = 101$
- Output of the hash function
  - › must always be less than size of array
  - › should be as evenly distributed as possible

4/15/2004

CSE 373 - SP 04 -- Dictionaries  
and Hashing

14

## Choosing the Hash Function

---

- What properties do we want from a hash function?
  - › Want universe of hash values to be distributed randomly to minimize collisions
  - › Don't want systematic nonrandom pattern in selection of keys to lead to systematic collisions
  - › Want hash value to depend on all values in entire key and their positions

4/15/2004

CSE 373 - SP 04 -- Dictionaries  
and Hashing

15

## The Key Values are Important

---

- Notice that one issue with all the hash functions is that the actual **content of the key set** matters
- The elements in  $K$  (the keys that are used) are quite possibly a restricted subset of  $U$ , not just a random collection
  - › variable names, words in the English language, reserved keywords, telephone numbers, etc, etc

4/15/2004

CSE 373 - SP 04 -- Dictionaries  
and Hashing

16



# Simple Hashes

- It's possible to have very simple hash functions if you are certain of your keys
- For example,
  - › suppose we know that the keys  $s$  will be real numbers uniformly distributed over  $0 \leq s < 1$
  - › Then a very fast, very good hash function is
    - $\text{hash}(s) = \text{floor}(s \cdot m)$
    - where  $m$  is the size of the table

4/15/2004

CSE 373 - SP 04 -- Dictionaries  
and Hashing

17

# Example of a Very Simple Mapping

- $\text{hash}(s) = \text{floor}(s \cdot m)$  maps from  $0 \leq s < 1$  to  $0..m-1$ 
  - ›  $m = 10$

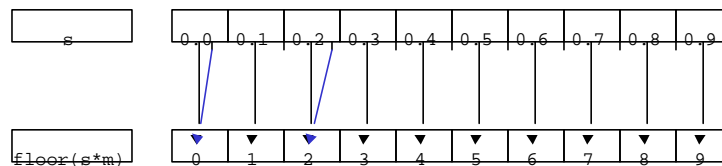

Note the even distribution. There are collisions, but we will deal with them later.

4/15/2004

CSE 373 - SP 04 -- Dictionaries  
and Hashing

18

## Perfect Hashing

- In some cases it's possible to map a known set of keys uniquely to a set of index values
- You must know every single key beforehand and be able to derive a function that works *one-to-one*

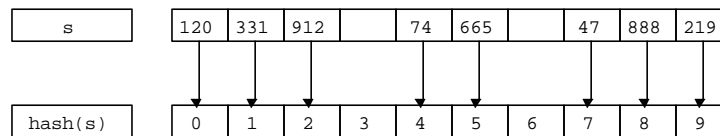

4/15/2004

CSE 373 - SP 04 -- Dictionaries  
and Hashing

19

## Mod Hash Function

- One solution for a less constrained key set
  - › modular arithmetic
- a **mod** size
  - › remainder when "a" is divided by "size"
  - › in C or Java this is written as `r = a % size;`
  - › If TableSize = 251
    - $408 \bmod 251 = 157$
    - $352 \bmod 251 = 101$

4/15/2004

CSE 373 - SP 04 -- Dictionaries  
and Hashing

20

## Modulo Mapping

- $a \bmod m$  maps from integers to  $0..m-1$ 
  - › one to one? no
  - › onto? yes

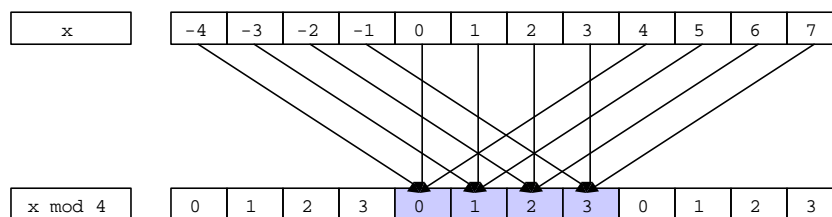

4/15/2004

CSE 373 - SP 04 -- Dictionaries  
and Hashing

21

## Hashing Integers

- If keys are integers, we can use the hash function:
  - ›  $\text{Hash}(\text{key}) = \text{key} \bmod \text{TableSize}$
- **Problem 1:** What if TableSize is 11 and all keys are 2 repeated digits? (eg, 22, 33, ...)
  - › all keys map to the same index
  - › Need to pick TableSize carefully: often, a prime number

4/15/2004

CSE 373 - SP 04 -- Dictionaries  
and Hashing

22

## Nonnumerical Keys

- Many hash functions assume that the universe of keys is the natural numbers  $\mathbf{N}=\{0,1,\dots\}$
- Need to find a function to convert the actual key to a natural number quickly and effectively before or during the hash calculation
- Generally work with the ASCII character codes when converting strings to numbers

4/15/2004

CSE 373 - SP 04 -- Dictionaries  
and Hashing

23

## Characters to Integers

- If keys are strings can get an integer by adding up ASCII values of characters in key
- We are converting a very large string  $c_0c_1c_2 \dots c_n$  to a relatively small number  $c_0+c_1+c_2+\dots+c_n \bmod \text{size}$ .

character	C	S	E		3	7	3	<0>
ASCII value	67	83	69	32	51	55	51	0

4/15/2004

CSE 373 - SP 04 -- Dictionaries  
and Hashing

24

## Hash Must be Onto Table

---

- **Problem 2:** What if *TableSize* is 10,000 and all keys are 8 or less characters long?
  - › chars have values between 0 and 127
  - › Keys will hash only to positions 0 through  $8 \cdot 127 = 1016$
- **Need to distribute keys over the entire table or the extra space is wasted**

4/15/2004

CSE 373 - SP 04 -- Dictionaries  
and Hashing

25

## Problems with Adding Characters

---

- Problems with adding up character values for string keys
  - › **If string keys are short, will not hash evenly to all of the hash table**
  - › **Different character combinations hash to same value**
    - “abc”, “bca”, and “cab” all add up to the same value (recall this was Problem 1)

4/15/2004

CSE 373 - SP 04 -- Dictionaries  
and Hashing

26

## Characters as Integers

---

- A character string can be thought of as a base 256 number. The string  $c_1c_2\dots c_n$  can be thought of as the number  $c_n + 256c_{n-1} + 256^2c_{n-2} + \dots + 256^{n-1}c_1$
- Use Horner's Rule to Hash! (see Ex. 2.14)

```
r = 0;
for i = 1 to n do
  r := (c[i] + 256*r) mod TableSize
```

4/15/2004

CSE 373 - SP 04 -- Dictionaries  
and Hashing

27

## Collisions

---

- A **collision** occurs when two different keys hash to the same value
  - › E.g. For  $TableSize = 17$ , the keys 18 and 35 hash to the same value for the mod17 hash function
  - ›  $18 \bmod 17 = 1$  and  $35 \bmod 17 = 1$
- Cannot store both data records in the same slot in array!

4/15/2004

CSE 373 - SP 04 -- Dictionaries  
and Hashing

28

# Collision Resolution

- **Separate Chaining**
  - › Use data structure (such as a linked list) to store multiple items that hash to the same slot
- **Open addressing (or probing)**
  - › search for empty slots using a second function and store item in first empty slot that is found

4/15/2004

CSE 373 - SP 04 -- Dictionaries  
and Hashing

29

# Resolution by Chaining

- Each hash table cell holds pointer to linked list of records with same hash value
- **Collision: Insert item into linked list**
- **To Find an item: compute hash value, then do Find on linked list**
- Note that there are potentially as many as TableSize lists

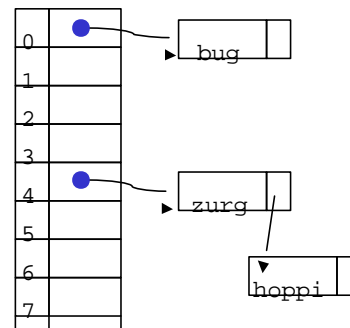

4/15/2004

CSE 373 - SP 04 -- Dictionaries  
and Hashing

30

## Why Lists?

---

- Can use List ADT for Find/Insert/Delete in linked list
  - ›  $O(N)$  runtime where  $N$  is the number of elements in the particular chain
- Can also use Binary Search Trees
  - ›  $O(\log N)$  time instead of  $O(N)$
  - › But the number of elements to search through should be small (otherwise the hashing function is bad or the table is too small)
  - › generally not worth the overhead of BSTs

4/15/2004

CSE 373 - SP 04 -- Dictionaries  
and Hashing

31

## Load Factor of a Hash Table

---

- Let  $N$  = number of items to be stored
- Load factor  $\lambda = N/\text{TableSize}$ 
  - ›  $\text{TableSize} = 101$  and  $N = 505$ , then  $\lambda = 5$
  - ›  $\text{TableSize} = 101$  and  $N = 10$ , then  $\lambda = 0.1$
- **Average** length of chained list =  $\lambda$  and so **average time** for accessing an item =  
 $O(1) + O(\lambda)$ 
  - › Want  $\lambda$  to be smaller than 1 but close to 1 if good hashing function (i.e.  $\text{TableSize} \approx N$ )
  - › With chaining hashing continues to work for  $\lambda > 1$

4/15/2004

CSE 373 - SP 04 -- Dictionaries  
and Hashing

32



## Resolution by Open Addressing

---

- No links, all keys are in the table
  - › reduced overhead saves space
- When searching for  $x$ , check locations  $h_1(x), h_2(x), h_3(x), \dots$  until either
  - ›  $x$  is found; or
  - › we find an empty location ( $x$  not present)
- Various flavors of open addressing differ in which probe sequence they use

4/15/2004

CSE 373 - SP 04 -- Dictionaries  
and Hashing

33

## Cell Full? Keep Looking.

---

- $h_i(x) = (\text{Hash}(x) + F(i)) \bmod \text{TableSize}$ 
  - › Define  $F(0) = 0$
- $F$  is the collision resolution function.  
Some possibilities:
  - › Linear:  $F(i) = i$
  - › Quadratic:  $F(i) = i^2$
  - › Double Hashing:  $F(i) = i \cdot \text{Hash}_2(x)$

4/15/2004

CSE 373 - SP 04 -- Dictionaries  
and Hashing

34

## Linear Probing

---

- When searching for  $\kappa$ , check locations  $h(\kappa)$ ,  $h(\kappa)+1$ ,  $h(\kappa)+2$ , ...  $\text{mod TableSize}$  until either
  - >  $\kappa$  is found; or
  - > we find an empty location ( $\kappa$  not present)
- If table is very sparse, almost like separate chaining.
- When table starts filling, we get clustering but still constant average search time.
- Full table  $\Rightarrow$  infinite loop.

4/15/2004

CSE 373 - SP 04 -- Dictionaries  
and Hashing

35

## Primary Clustering Problem

---

- Once a block of a few contiguous occupied positions emerges in table, it becomes a “target” for subsequent collisions
- As clusters grow, they also merge to form larger clusters.
- **Primary clustering:** elements that hash to different cells probe same alternative cells

4/15/2004

CSE 373 - SP 04 -- Dictionaries  
and Hashing

36

## Quadratic Probing

---

- When searching for  $x$ , check locations  $h_1(x), h_1(x) + 1^2, h_1(x) + 2^2, \dots \bmod \text{TableSize}$  until either
  - ›  $x$  is found; or
  - › we find an empty location ( $x$  not present)
- No primary clustering but secondary clustering possible

4/15/2004

CSE 373 - SP 04 -- Dictionaries  
and Hashing

37

## Double Hashing

---

- When searching for  $x$ , check locations  $h_1(x), h_1(x) + h_2(x), h_1(x) + 2 \cdot h_2(x), \dots \bmod \text{TableSize}$  until either
  - ›  $x$  is found; or
  - › we find an empty location ( $x$  not present)
- Must be careful about  $h_2(x)$ 
  - › Not 0 and not a divisor of  $m$
  - › eg,  $h_1(k) = k \bmod m_1, h_2(k) = 1 + (k \bmod m_2)$   
where  $m_2$  is slightly less than  $m_1$

4/15/2004

CSE 373 - SP 04 -- Dictionaries  
and Hashing

38

## Rules of Thumb

---

- Separate chaining is simple but wastes space...
- Linear probing uses space better, is fast when tables are sparse
- Double hashing is space efficient, fast (get initial hash and increment at the same time), needs careful implementation

4/15/2004

CSE 373 - SP 04 -- Dictionaries  
and Hashing

39

## Rehashing – Rebuild the Table

---

- Need to use lazy deletion if we use probing (why?)
  - › Need to mark array slots as deleted after Delete
  - › consequently, deleting doesn't make the table any less full than it was before the delete
- If table gets too full ( $\lambda \approx 1$ ) or if many deletions have occurred, running time gets too long and Inserts may fail

4/15/2004

CSE 373 - SP 04 -- Dictionaries  
and Hashing

40

# Rehashing

- Build a bigger hash table of approximately twice the size when  $\lambda$  exceeds a particular value
  - › Go through old hash table, ignoring items marked deleted
  - › Recompute hash value for each non-deleted key and put the item in new position in new table
  - › Cannot just copy data from old table because the bigger table has a new hash function
- Running time is  $O(N)$  but happens very infrequently
  - › Not good for real-time safety critical applications

4/15/2004

CSE 373 - SP 04 -- Dictionaries  
and Hashing

41

# Rehashing Example

- Open hashing –  $h_1(x) = x \bmod 5$  rehashes to  $h_2(x) = x \bmod 11$ .

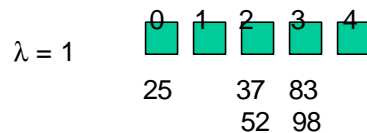

4/15/2004

CSE 373 - SP 04 -- Dictionaries  
and Hashing

42

## Caveats

---

- Hash functions are very often the cause of performance bugs.
- Hash functions often make the code not portable.
- If a particular hash function behaves badly on your data, then pick another.
- Always check where the time goes