

# Pipeline Control unit (highly abstracted)

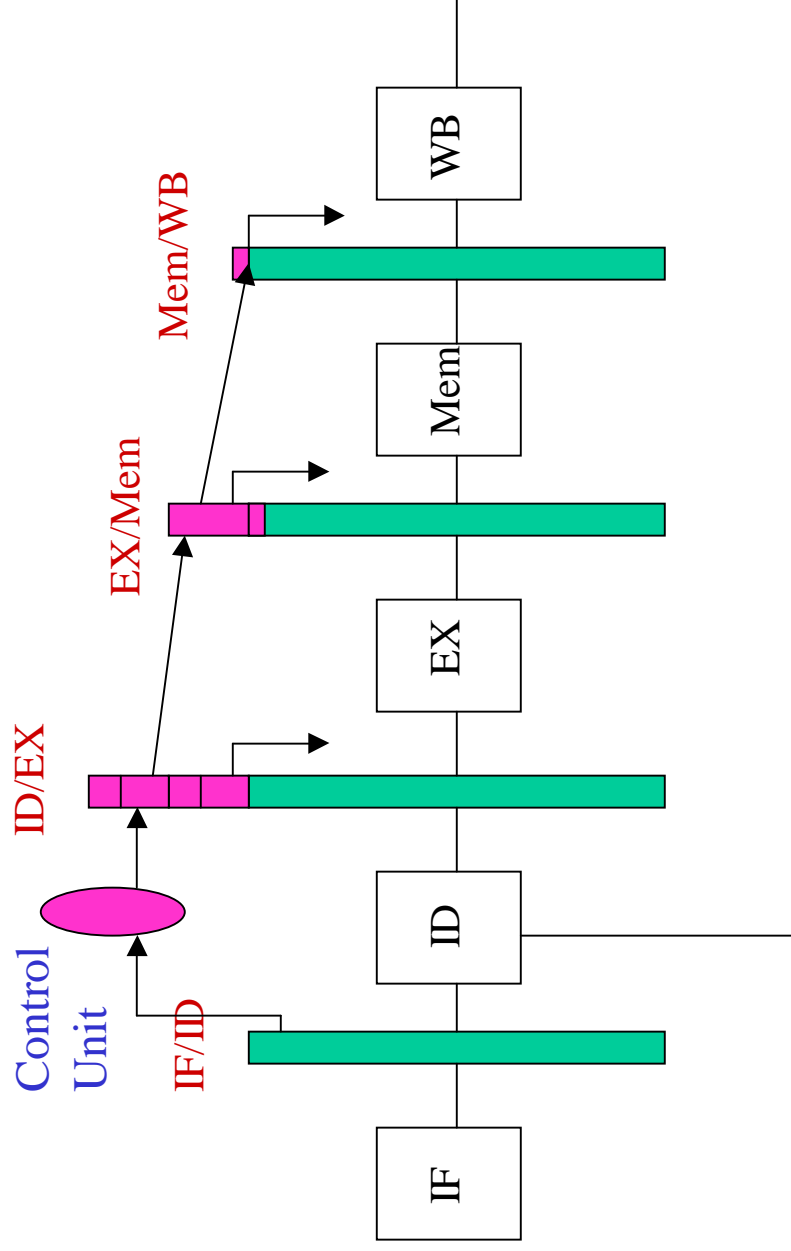

Where are the control signals needed?

- Very much like in multiple cycle implementation for the case of an ideal pipeline
- Cf. Figure 6.25

## Control (ideal case)

- Control signals are split among the 5 stages. For the ideal case no need for additional control (but just wait!)
- *Stage 1*: nothing special to control
  - read instr. memory and increment PC asserted at each cycle
- *Stage 2*: nothing. All instructions do the same
- *Stage 3*: Instruction dependent
  - Control signals for ALU sources and ALUop
  - Control signal for Regdest so the right name is passed along
- *Stage 4*: Control for memory (read/write) and for branches
- *Stage 5*: Control for source of what to write in the

destination register

# Hazards

- Recall
  - *structural* hazards: lack of resources (won't happen in simple pipeline)
  - *data* hazards: due to dependencies between executing instructions
  - *control* hazards: flow of control is not sequential

## Data dependencies

- The result of an operation is needed before it is stored back in the register file

– Example:

add \$7, \$12, \$15

# put result in register 7

sub \$8, \$7, \$12

# use register 7 as a source

and \$9, \$14, \$7

# use register 7 as a source

- The above dependence is called RAW (Read After Write)
- Note that there is no dependency for register 12 which is used as a source in two operations
- WAW (Write After Write) and WAR (Write After Read) dependencies can exist but not in our simple pipeline

# Data dependencies in the pipe

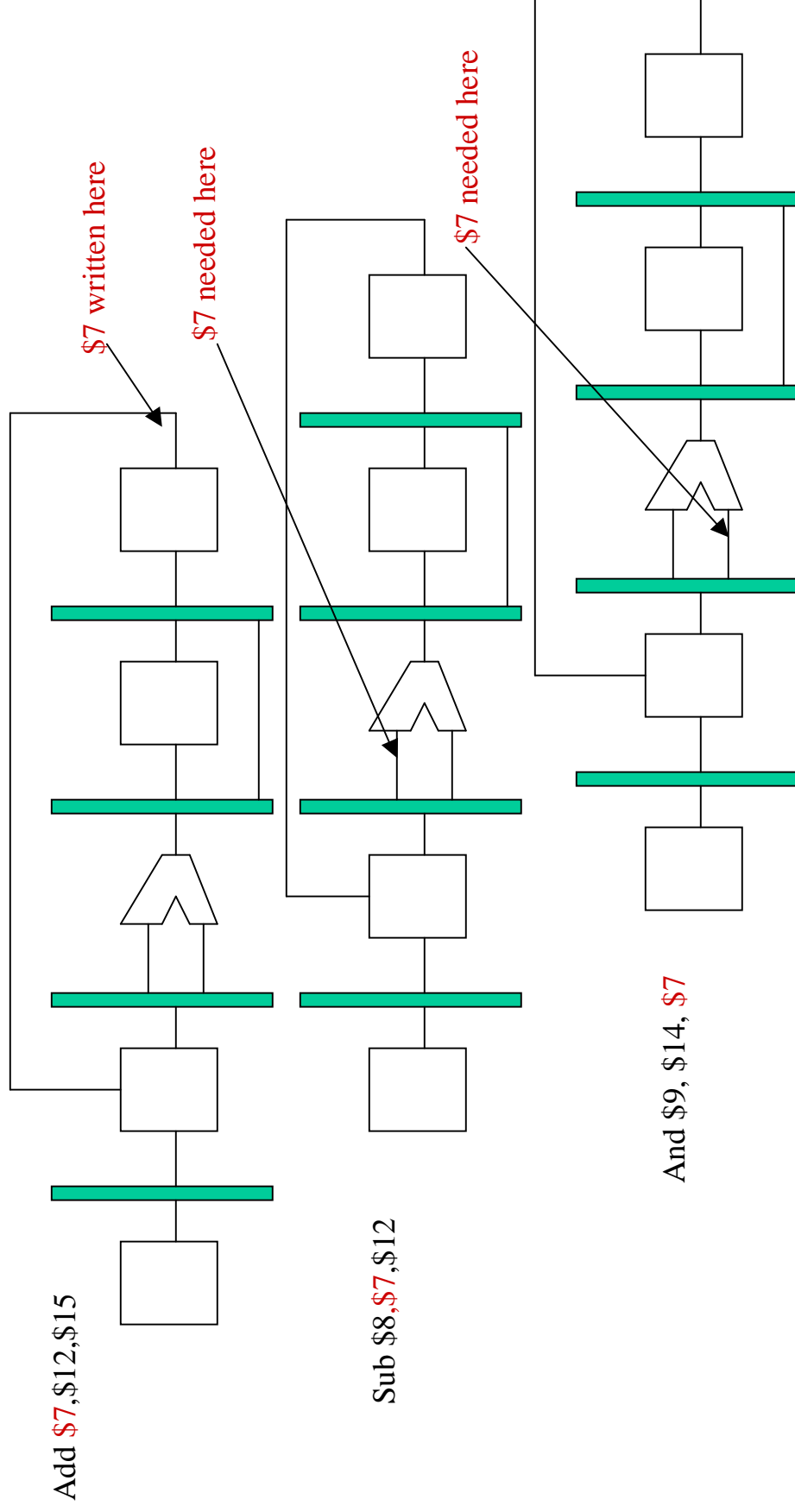

## Occurrences of data dependencies

- Data dependence occurs when:
  - An instruction wants to read a register in stage 2, and
  - One instruction in either stage 3 or stage 4 is going to write that register
    - Note that if the instruction writing the register is in stage 5, this is fine since we can write a register and read it in the same cycle
- Data dependencies can occur between:
  - Arithmetic instructions
  - A load and an arithmetic instruction needing the result of a load
  - An arithmetic instruction and a load/store (to compute the address)
  - An arithmetic instruction and a branch (to compare registers)

## Detection of data dependencies

- When an instruction reaches stage 2, the control unit will detect whether the names of the result registers of the **two previous instructions** match the name of the source registers for the current instruction.
  - Examples: EX/Mem write-register name = ID/EX rs
  - Mem/WB write-register name = ID/EX rt



## Resolving data dependencies

- There are several possibilities:
  - Have the compiler generate “no-ops”, i.e., instructions that do nothing while passing through the pipeline (original MIPS at Stanford; found to be too complex)
  - Stall the pipeline when the hardware detects the dependency, i.e., create *bubbles* (the resulting delays are the same as for no-ops)
  - Forwarding the result, generated in stage 3 or stage 4, to the appropriate input of the ALU. This is called *forwarding* or *bypassing*.

# Example of stalls

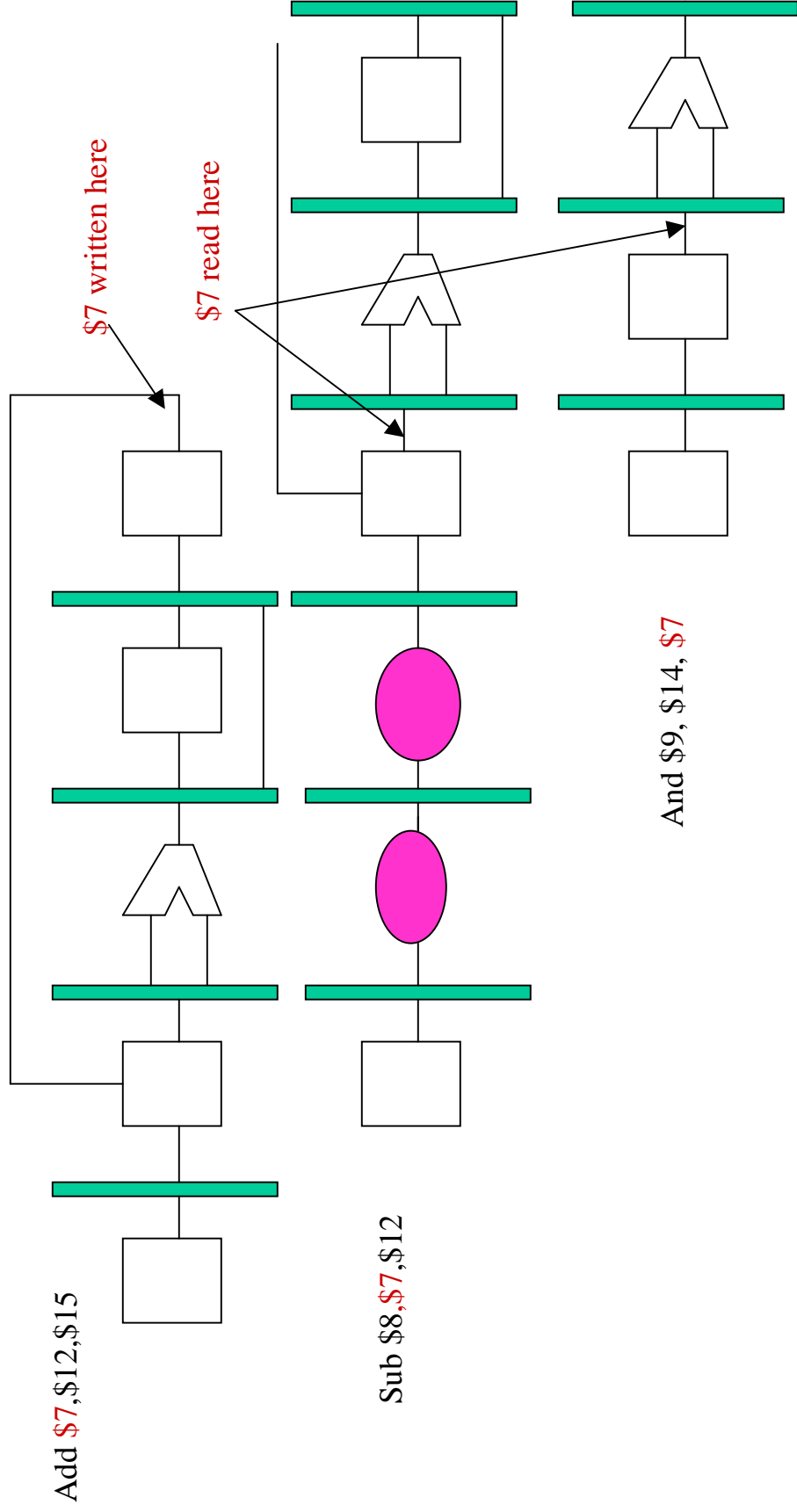

## How to detect stalls and additional control

- Between instruction  $i+1$  and instruction  $i$  (2 bubbles)  
ID/EX write-register = IF/ID read-register 1 or IF/ID read-register 2
- Between instruction  $i+2$  and instruction  $i$  (1 bubble)  
EX/Mem write-register = IF/ID read-register 1 or IF/ID read-register 2
- Note that we are stalling an instruction in stage 2 (decode) thus
  - We must prevent fetching new instructions (otherwise PC and current instruction would be clobbered in IF/ID)
  - so control to create bubbles (set all control lines to 0 from stage 2 on) and prevent new instruction fetches

## Forwarding

- Bubbles (or no-ops) are pessimistic since result is present before stage 5
  - In stage 3 for arithmetic instructions
  - In stage 4 for loads
- So why not forward directly the result from stage 3 (or 4) to the ALU
- Note that the state of the process (i.e., writing in registers) is still modified only in stage 5
  - The importance of this will become clear when we look at exceptions.

# Forwarding in the pipe

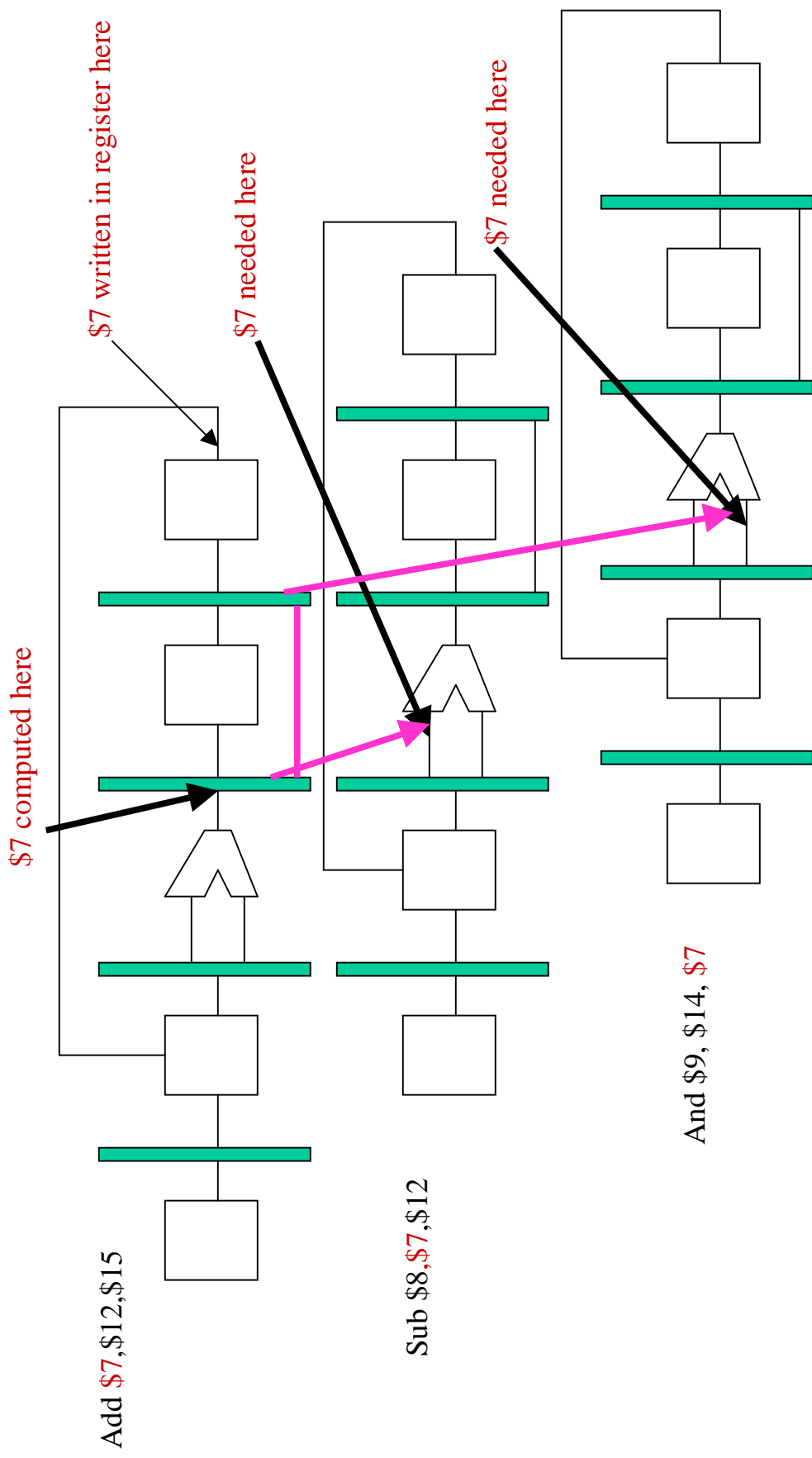

## Forwarding implementation

- Add busses to the data path so that inputs to ALU can be taken from
  - register file
  - EX/Mem pipeline register
  - Mem/WB pipeline register
- Have a “control forwarding unit” that detects
  - forwarding between instructions  $i+1$  and  $i$  and between instructions  $i+2$  and  $i$  (note that both can happen at the same time for the two sources)
- Expand muxes to allow these new choices

## Still need for stalling

- Alas, we can't get rid of bubbles completely because the result of a load is only available at the end of stage 4

– Example: Lw \$6,0(\$2)  
          Add \$7,\$6,\$4

We need to stall for 1 cycle and then forward

# The Load stalling case

