

CSE 451: Operating Systems
Winter 2007

Module 5
Threads

What's in a process?

- A process consists of (at least):
 - an address space
 - the code for the running program
 - the data for the running program
 - an execution stack and stack pointer (SP)
 - traces state of procedure calls made
 - the program counter (PC), indicating the next instruction
 - a set of general-purpose processor registers and their values
 - a set of OS resources
 - open files, network connections, sound channels, ...
- That's a lot of concepts bundled together!
- Today: decompose ...
 - an address space
 - threads of control
 - (other resources...)

Concurrency

- Imagine a web server, which might like to handle multiple requests concurrently
 - While waiting for the credit card server to approve a purchase for one client, it could be retrieving the data requested by another client from disk, and assembling the response for a third client from cached information
- Imagine a web client (browser), which might like to initiate multiple requests concurrently
 - The CSE home page has 46 “src= ...” html commands, each of which is going to involve a lot of sitting around! Wouldn't it be nice to be able to launch these requests concurrently?
- Imagine a parallel program running on a multiprocessor, which might like to employ “physical concurrency”
 - For example, multiplying a large matrix – split the output matrix into k regions and compute the entries in each region concurrently using k processors

What's needed?

- In each of these examples of concurrency (web server, web client, parallel program):
 - Everybody wants to run the same code
 - Everybody wants to access the same data
 - Everybody has the same privileges
 - Everybody uses the same resources (open files, network connections, etc.)
- But you'd like to have multiple hardware execution states:
 - an execution stack and stack pointer (SP)
 - traces state of procedure calls made
 - the program counter (PC), indicating the next instruction
 - a set of general-purpose processor registers and their values

How could we achieve this?

- Given the process abstraction as we know it:
 - fork several processes
 - cause each to *map* to the **same** physical memory to share data
 - see the `shmget()` system call for one way to do this (kind of)
- This is like making a pig fly – it's really inefficient
 - space: PCB, page tables, etc.
 - time: creating OS structures, fork and copy addr space, etc.
- Some equally bad alternatives for some of the examples:
 - Entirely separate web servers
 - Manually programmed asynchronous programming (non-blocking I/O) in the web client (browser)

Can we do better?

- Key idea:
 - separate the concept of a **process** (address space, etc.)
 - ...from that of a minimal “**thread of control**” (execution state: PC, etc.)
- This execution state is usually called a **thread**, or sometimes, a **lightweight process**

Threads and processes

- Most modern OS's (Mach, Chorus, NT, modern UNIX) therefore support two entities:
 - the **process**, which defines the address space and general process attributes (such as open files, etc.)
 - the **thread**, which defines a sequential execution stream within a process
- A thread is bound to a single process / address space
 - address spaces, however, can have multiple threads executing within them
 - sharing data between threads is cheap: all see the same address space
 - creating threads is cheap too!
- Threads become the unit of scheduling
 - processes / address spaces are just **containers** in which threads execute

The design space

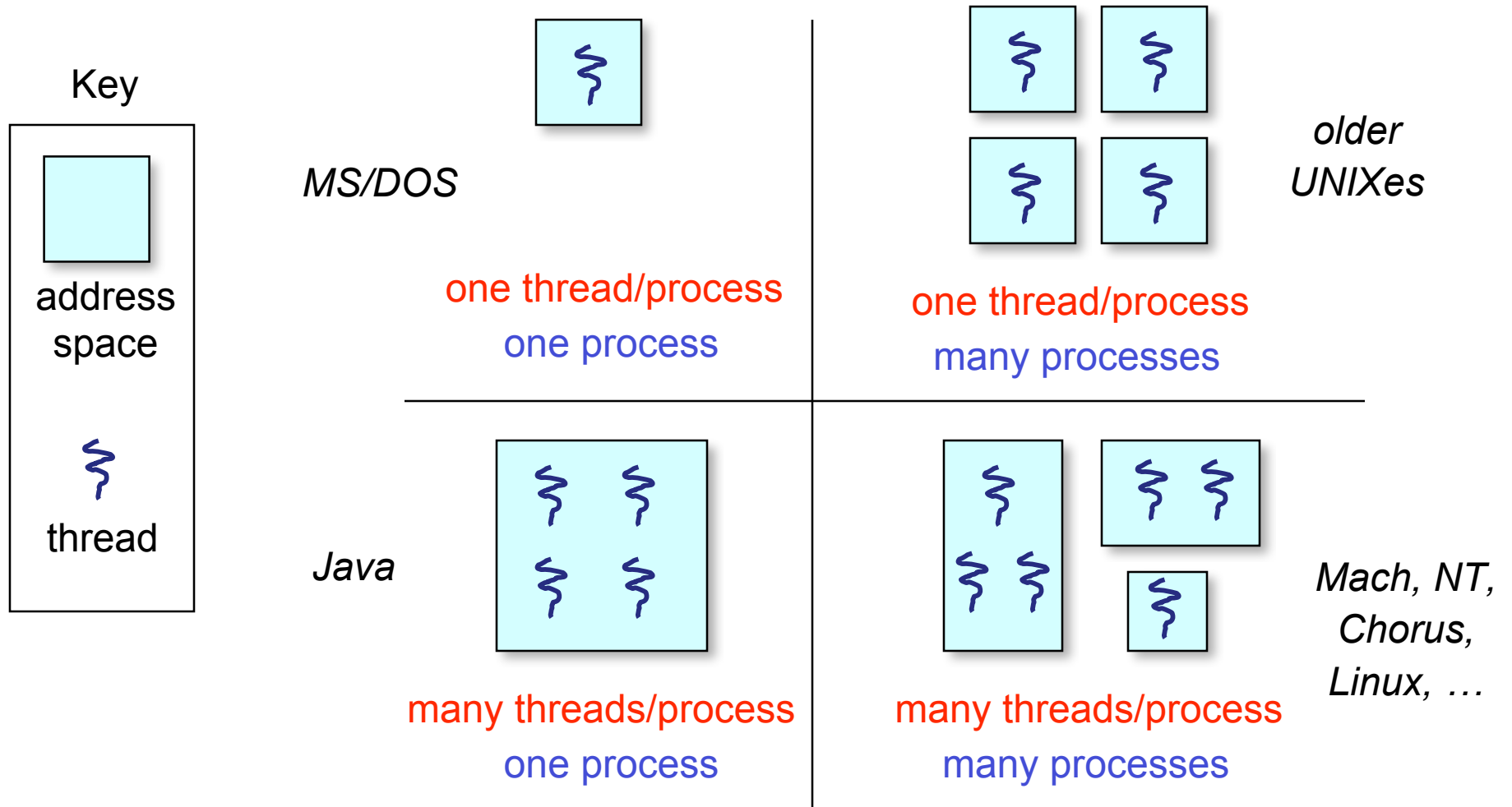

(old) Process address space

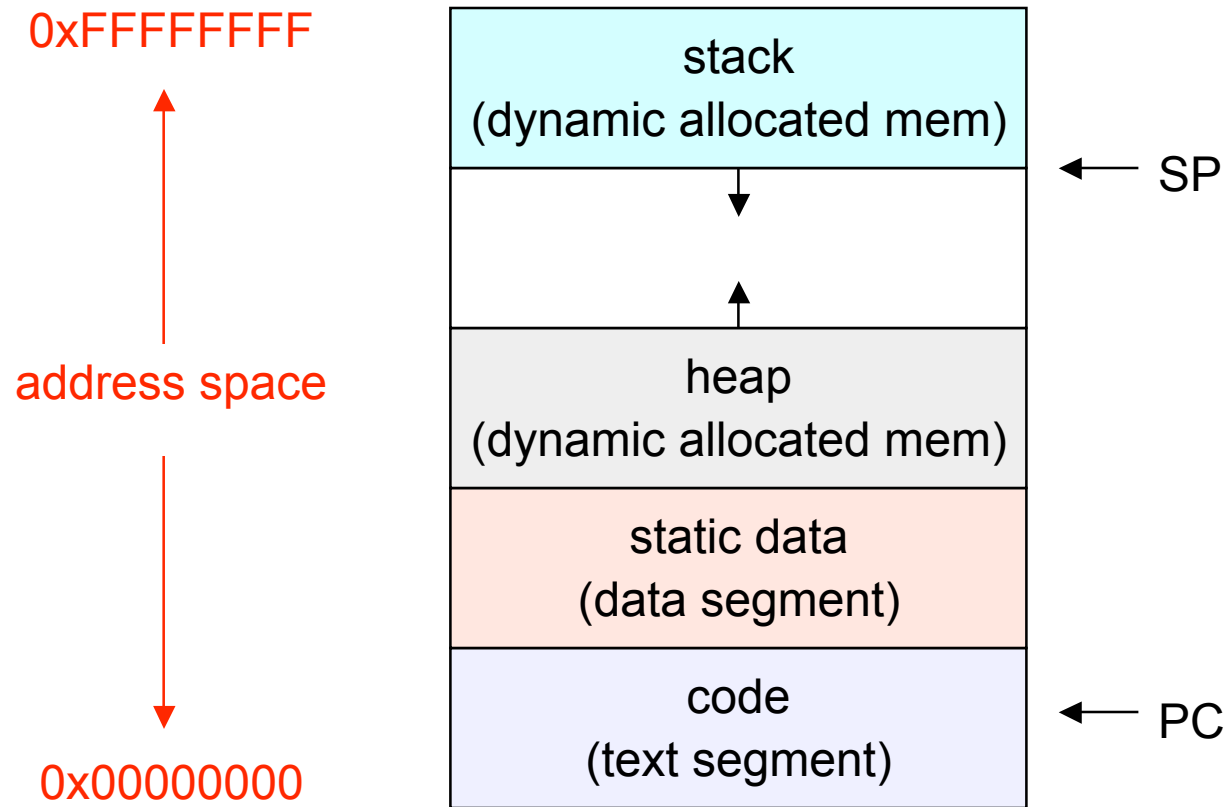

(new) Process address space with threads

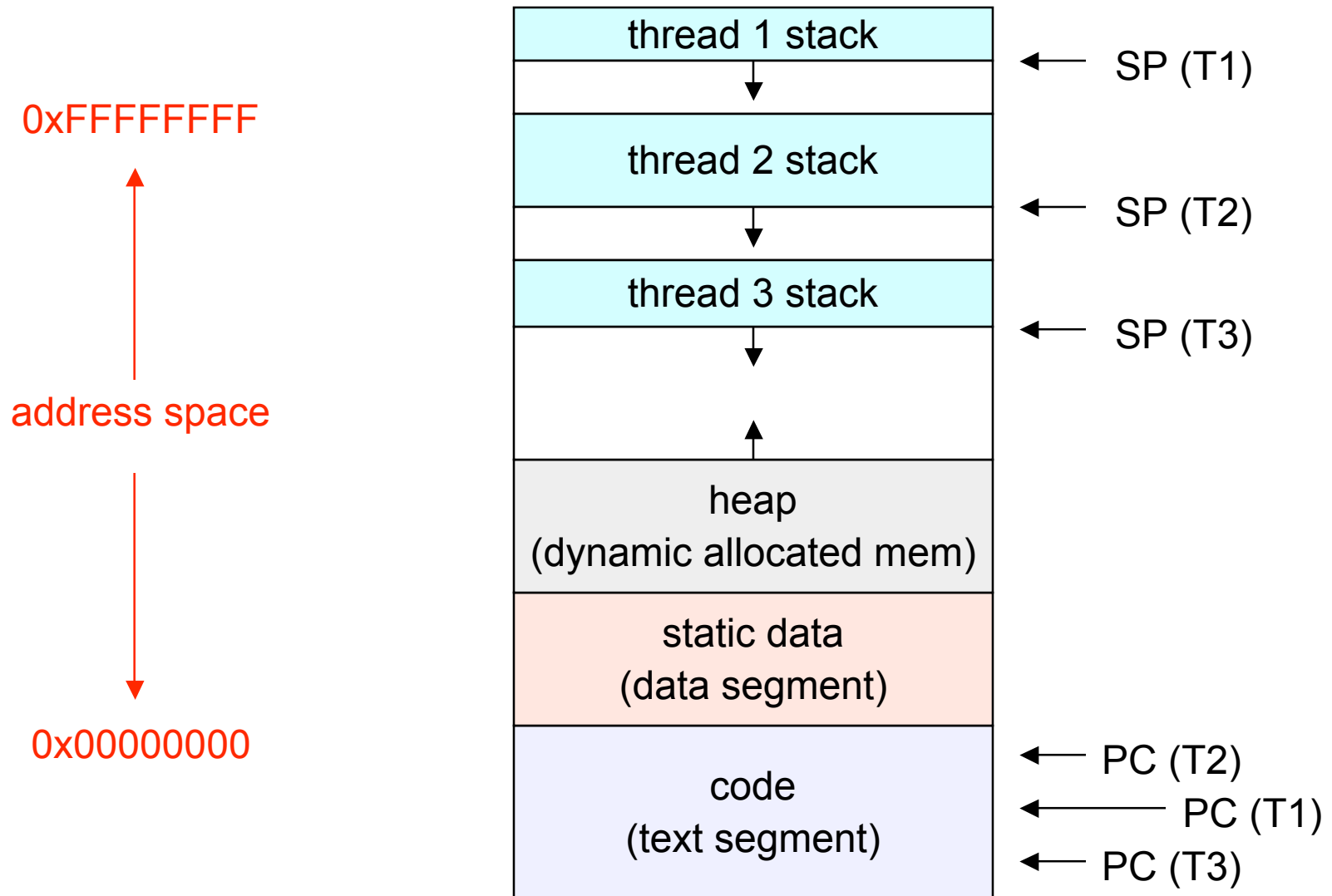

Process/thread separation

- Concurrency (multithreading) is useful for:
 - handling concurrent events (e.g., web servers and clients)
 - building parallel programs (e.g., matrix multiply, ray tracing)
 - improving program structure (the Java argument)
- Multithreading is useful even on a uniprocessor
 - even though only one thread can run at a time
- Supporting multithreading – that is, separating the concept of a **process** (address space, files, etc.) from that of a minimal **thread of control** (execution state), is a big win
 - creating concurrency does not require creating new processes
 - “faster / better / cheaper”

“Where do threads come from?”

- Natural answer: the kernel is responsible for creating/managing threads
 - for example, the kernel call to create a new thread would
 - allocate an execution stack within the process address space
 - create and initialize a Thread Control Block
 - stack pointer, program counter, register values
 - stick it on the ready queue
 - we call these **kernel threads**

“Where do threads come from?” (2)

- Threads can also be managed at the user level (that is, entirely from within the process)
 - a library linked into the program manages the threads
 - because threads share the same address space, the thread manager doesn't need to manipulate address spaces (which only the kernel can do)
 - threads differ (roughly) only in hardware contexts (PC, SP, registers), which can be manipulated by user-level code
 - the **thread package** multiplexes user-level threads on top of kernel thread(s), which it treats as “virtual processors”
 - we call these **user-level threads**

Kernel threads

- OS now manages threads *and* processes
 - all thread operations are implemented in the kernel
 - OS schedules all of the threads in a system
 - if one thread in a process blocks (e.g., on I/O), the OS knows about it, and can run other threads from that process
 - possible to overlap I/O and computation **inside** a process
- Kernel threads are cheaper than processes
 - less state to allocate and initialize
- But, they're still pretty expensive for fine-grained use (e.g., orders of magnitude more expensive than a procedure call)
 - thread operations are all system calls
 - context switch
 - argument checks
 - must maintain kernel state for each thread

User-level threads

- To make threads cheap and fast, they need to be implemented at the user level
 - managed entirely by user-level library, e.g., `libpthreads.a`
- User-level threads are small and fast
 - each thread is represented simply by a PC, registers, a stack, and a small **thread control block** (TCB)
 - creating a thread, switching between threads, and synchronizing threads are done via procedure calls
 - no kernel involvement is necessary!
 - user-level thread operations can be 10-100x faster than kernel threads as a result

Performance example

- On a 700MHz Pentium running Linux 2.2.16:
 - Processes
 - `fork/exit`: 251 μ s
 - Kernel threads
 - `pthread_create()/pthread_join()`: 94 μ s (2.5x faster)
 - User-level threads
 - `pthread_create()/pthread_join`: 4.5 μ s (another 20x faster)

Performance example (2)

- On a 700MHz Pentium running Linux 2.2.16:
- On a DEC SRC Firefly running Ultrix, 1989
 - Processes
 - `fork/exit`: 251 μ s / 11,300 μ s
 - Kernel threads
 - `pthread_create()/pthread_join()`: 94 μ s / 948 μ s (12x faster)
 - User-level threads
 - `pthread_create()/pthread_join`: 4.5 μ s / 34 μ s (another 28x faster)

The design space

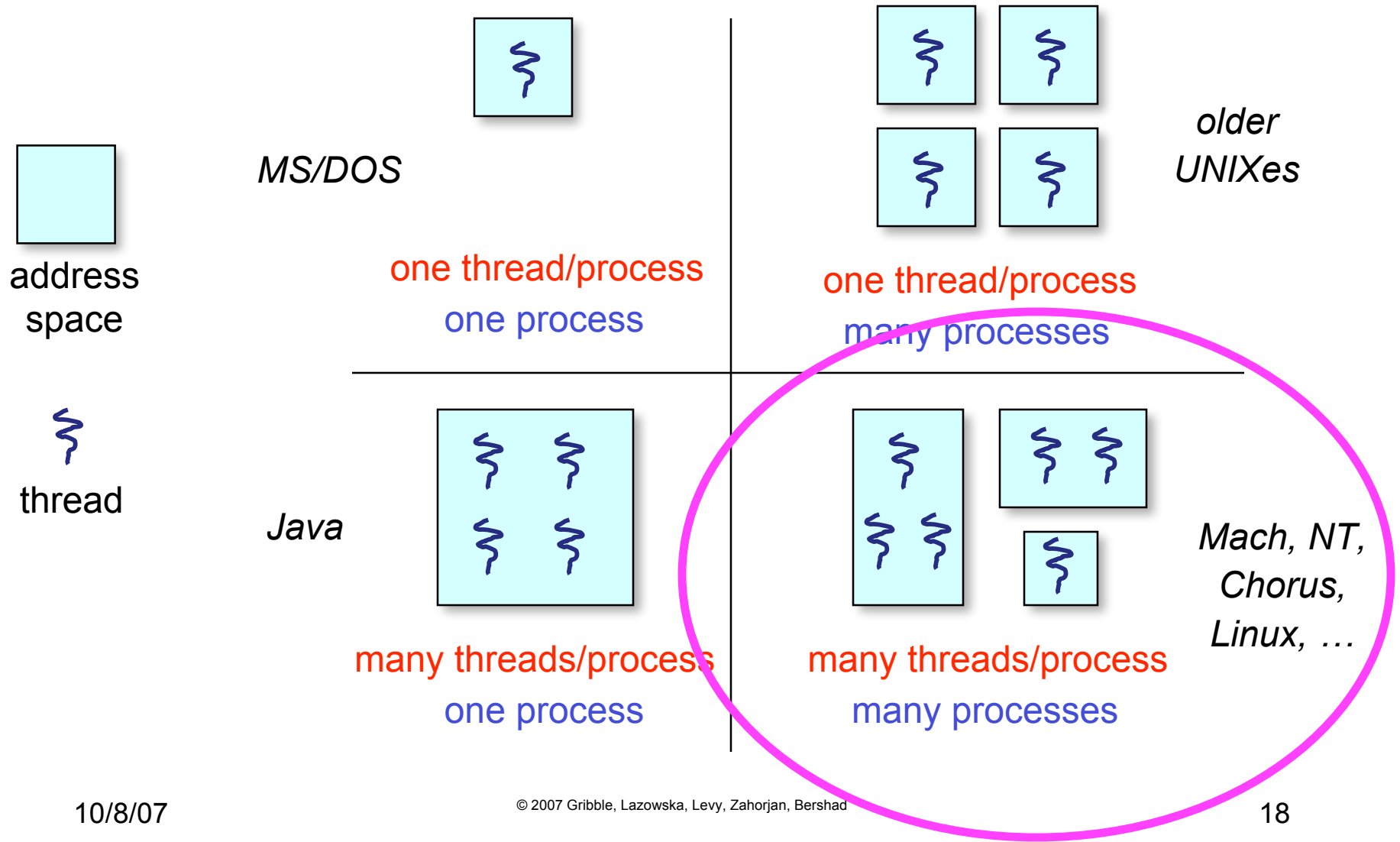

Kernel threads

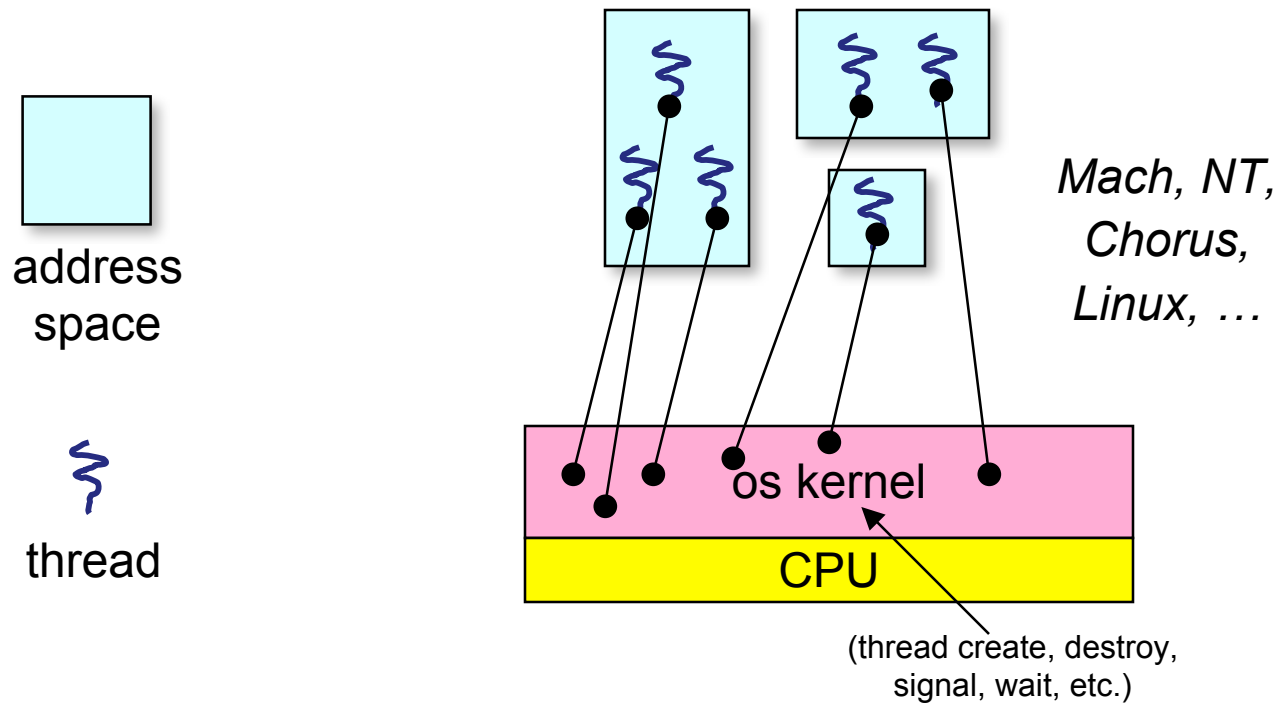

User-level threads, conceptually

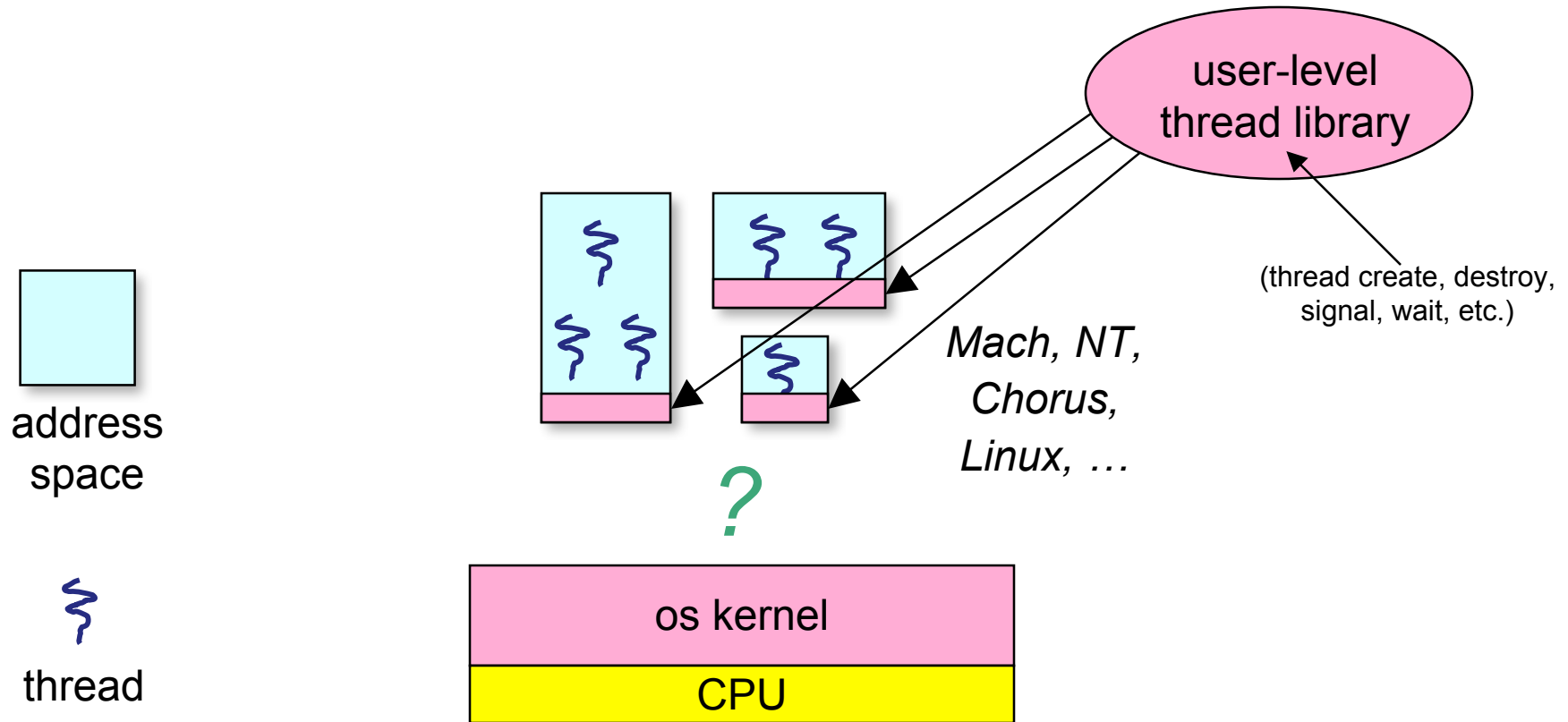

User-level threads, *really*

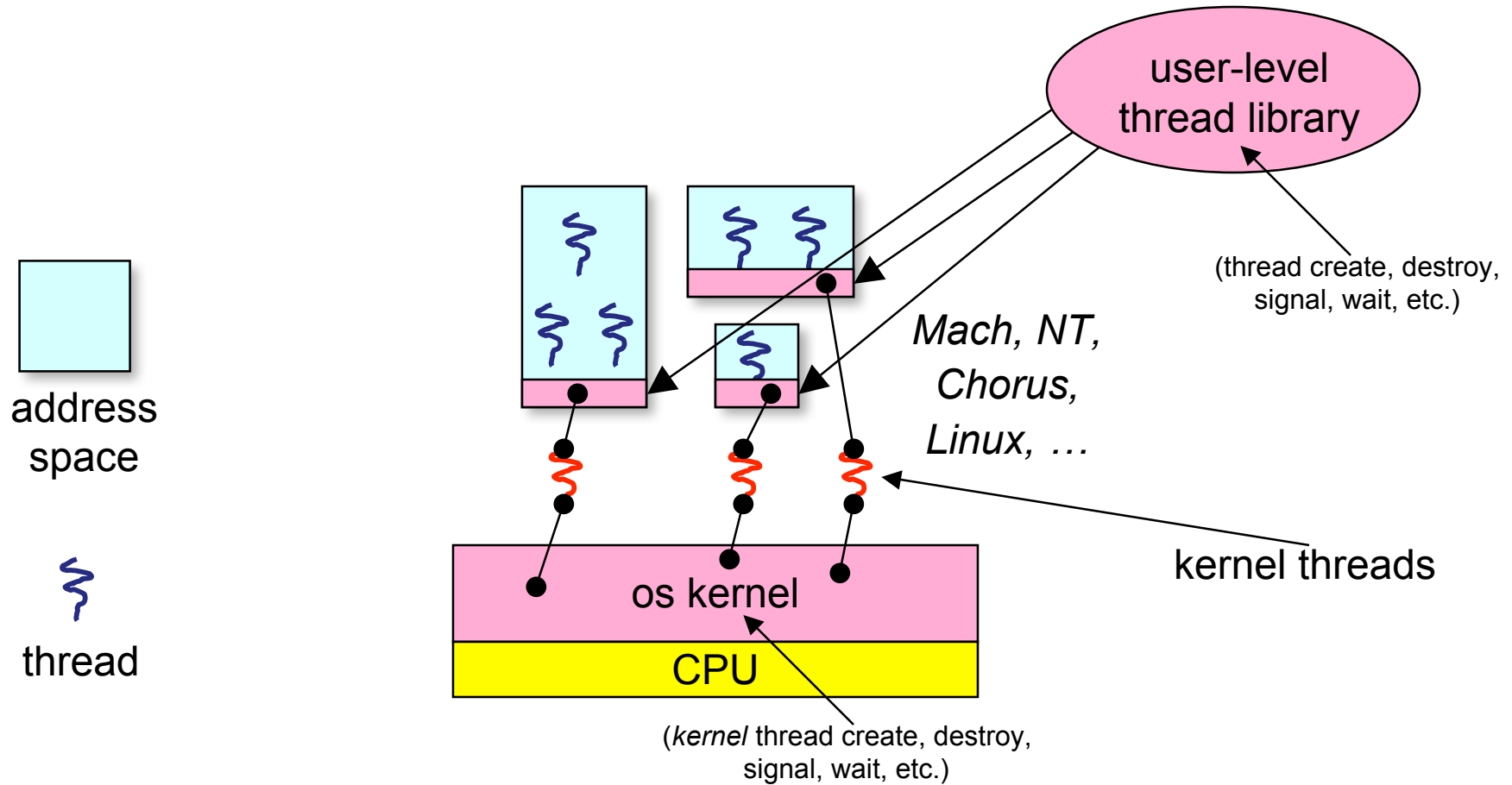

Multiple kernel threads “powering” each address space

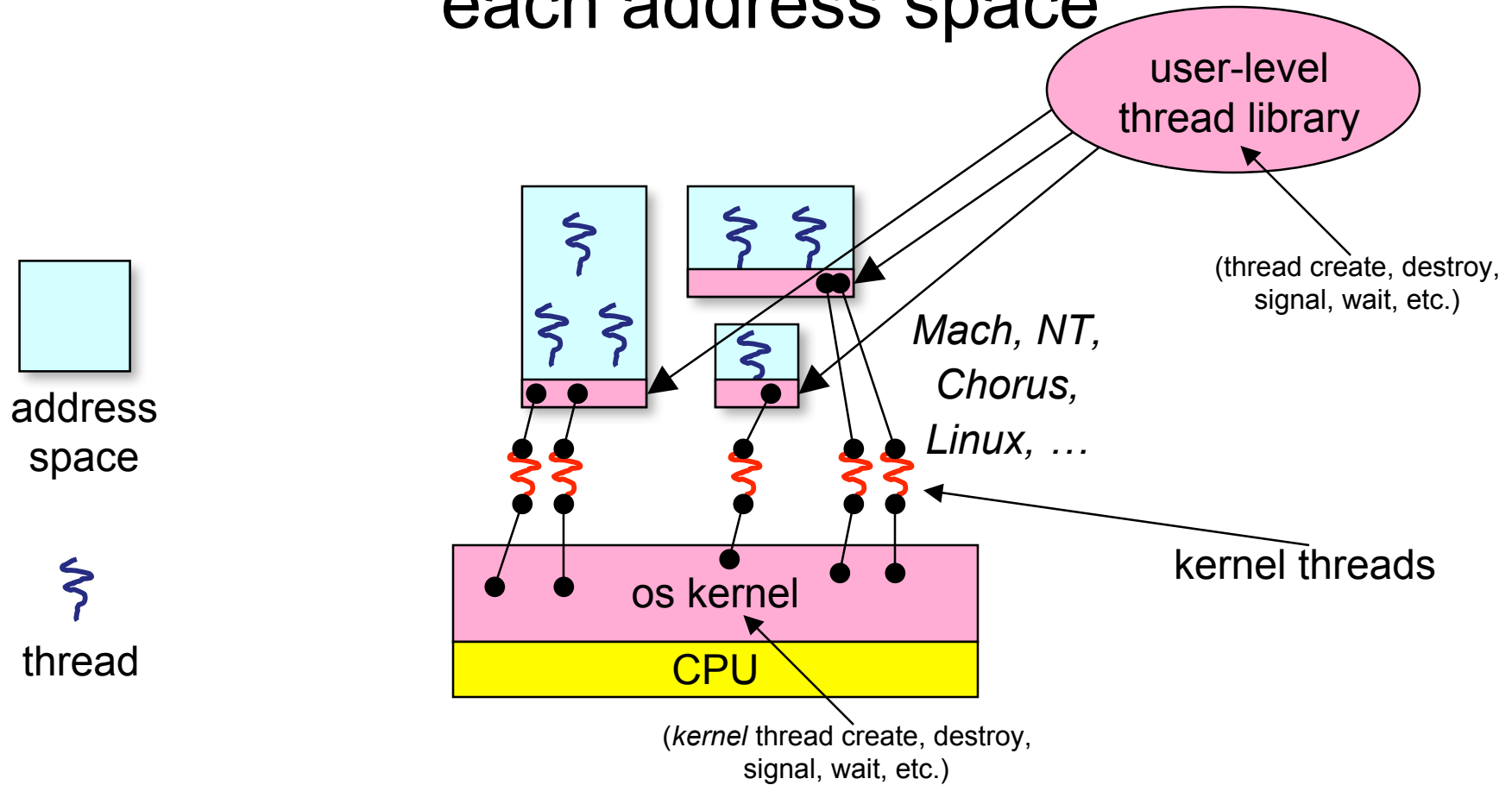

User-level thread implementation

- The kernel believes the user-level process is just a normal process running code
 - But, this code includes the thread support library and its associated thread scheduler
- The thread scheduler determines when a thread runs
 - it uses queues to keep track of what threads are doing: run, ready, wait
 - just like the OS and processes
 - but, implemented at user-level as a library

Thread interface

- This is taken from the POSIX `pthread` API:
 - `t = pthread_create(attributes, start_procedure)`
 - creates a new thread of control
 - new thread begins executing at `start_procedure`
 - `pthread_cond_wait(condition_variable)`
 - the calling thread blocks, sometimes called `thread_block()`
 - `pthread_signal(condition_variable)`
 - starts the thread waiting on the condition variable
 - `pthread_exit()`
 - terminates the calling thread
 - `pthread_wait(t)`
 - waits for the named thread to terminate

How to keep a user-level thread from hogging the CPU?

- Strategy 1: force everyone to cooperate
 - a thread willingly gives up the CPU by calling `yield()`
 - `yield()` calls into the scheduler, which context switches to another ready thread
 - what happens if a thread never calls `yield()`?
- Strategy 2: use preemption
 - scheduler requests that a timer interrupt be delivered by the OS periodically
 - usually delivered as a UNIX signal (`man signal`)
 - signals are just like software interrupts, but delivered to user-level by the OS instead of delivered to OS by hardware
 - at each timer interrupt, scheduler gains control and context switches as appropriate

Thread context switch

- Very simple for user-level threads:
 - save context of currently running thread
 - push machine state onto thread stack
 - restore context of the next thread
 - pop machine state from next thread's stack
 - return as the new thread
 - execution resumes at PC of next thread
- This is all done by assembly language
 - it works at the level of the procedure calling convention
 - thus, it cannot be implemented using procedure calls
 - e.g., a thread might be preempted (and then resumed) in the middle of a procedure call

What if a thread tries to do I/O?

- The kernel thread “powering” it is lost for the duration of the (synchronous) I/O operation!
- Could have one kernel thread “powering” each user-level thread
 - no real difference from kernel threads – “common case” operations (e.g., synchronization) would be quick
- Could have a limited-size “pool” of kernel threads “powering” all the user-level threads in the address space
 - the kernel will be scheduling these threads, obviously to what’s going on at user-level

What if the kernel preempts a thread holding a lock?

- Other threads will be unable to enter the critical section and will block (stall)
 - tradeoff, as with everything else
- Solving this requires coordination between the kernel and the user-level thread manager
 - “scheduler activations”
 - a research paper from UW with huge effect on practice
 - each process can request one or more kernel threads
 - process is given responsibility for mapping user-level threads onto kernel threads
 - kernel promises to notify user-level before it suspends or destroys a kernel thread
 - *ACM TOCS 10,1*

Summary

- You really want multiple threads per address space
- Kernel threads are much more efficient than processes, but they're still not cheap
 - all operations require a kernel call and parameter verification
- User-level threads are:
 - fast
 - great for common-case operations
 - creation, synchronization, destruction
 - can suffer in uncommon cases due to kernel obliviousness
 - I/O
 - preemption of a lock-holder
- Scheduler activations are the answer
 - pretty subtle though