

**CSE 451: Operating Systems  
Autumn 2008**

**Module 5  
Threads**

Hank Levy

**What's in a process?**

- A process consists of (at least):
  - an address space
  - the code for the running program
  - the data for the running program
  - an execution stack and stack pointer (SP)
    - traces state of procedure calls made
  - the program counter (PC), indicating the next instruction
  - a set of general-purpose processor registers and their values
  - a set of OS resources
    - open files, network connections, sound channels, ...
- That's a lot of concepts bundled together!

10/5/2008

HML

2

**Concurrency**

- Imagine a web server, which might like to handle multiple requests concurrently
  - While waiting for the credit card server to approve a purchase for one client, it could be retrieving the data requested by another client from disk, and assembling the response for a third client from cached information
- Imagine a web client (browser), which might like to initiate multiple requests concurrently
  - The CSE home page has 46 "src= ..." html commands, each of which is going to involve a lot of sitting around! Wouldn't it be nice to be able to launch these requests concurrently?
- Imagine a parallel program running on a multiprocessor, which might like to concurrently employ multiple processors
  - For example, multiplying a large matrix – split the output matrix into k regions and compute the entries in each region concurrently using k processors

10/5/2008

HML

3

**What's needed?**

- In each of these examples of concurrency (web server, web client, parallel program):
  - Everybody wants to run the same code
  - Everybody wants to access the same data
  - Everybody has the same privileges
  - Everybody uses the same resources (open files, network connections, etc.)
- But you'd like to have multiple hardware execution states:
  - an execution stack and stack pointer (SP)
    - traces state of procedure calls made
  - the program counter (PC), indicating the next instruction
  - a set of general-purpose processor registers and their values

10/5/2008

HML

4

## How could we achieve this?

- Given the process abstraction as we know it:
  - fork several processes
  - cause each to map to the *same* address space to share data
    - see the `shmget()` system call for one way to do this (kind of)
- This is like making a pig fly – it's really inefficient
  - space: PCB, page tables, etc.
  - time: creating OS structures, fork and copy addr space, etc.
- Some equally bad alternatives for some of the cases:
  - Entirely separate web servers
  - Asynchronous programming (explicitly programming of non-blocking I/Os) in the web client (browser)

10/5/2008

HML

5

## Can we do better?

- Key idea:
  - separate the concept of a **process** (address space, etc.)
  - from that of a minimal **"thread of control"** (execution state: PC, etc.)
- This execution state is usually called a **thread**, or sometimes, a **lightweight process**

10/5/2008

HML

6

## Threads and processes

- Most modern OS's (Mach, Chorus, Win/XP, modern Unix) therefore support two entities:
  - the **process**, which defines the address space and general process attributes (such as open files, etc.)
  - the **thread**, which defines a sequential execution stream within a process
- A thread is bound to a single process
  - processes, however, can have multiple threads executing within them
  - sharing data between threads is cheap: all see same address space
- Threads become the unit of scheduling
  - processes are just **containers** in which threads execute

10/5/2008

HML

7

## The design space

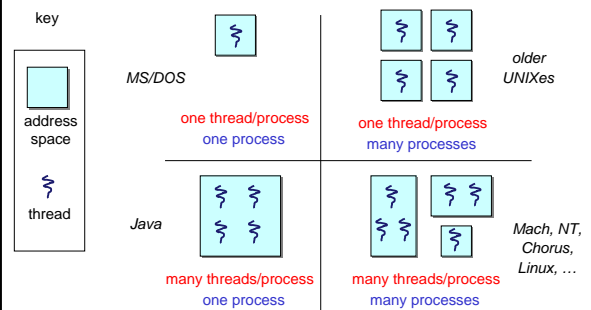

10/5/2008

HML

8

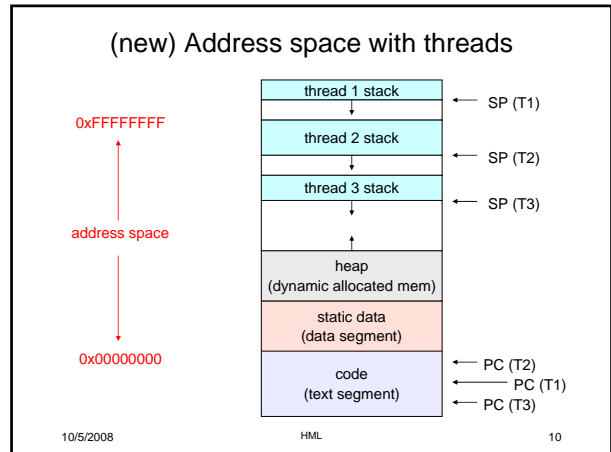
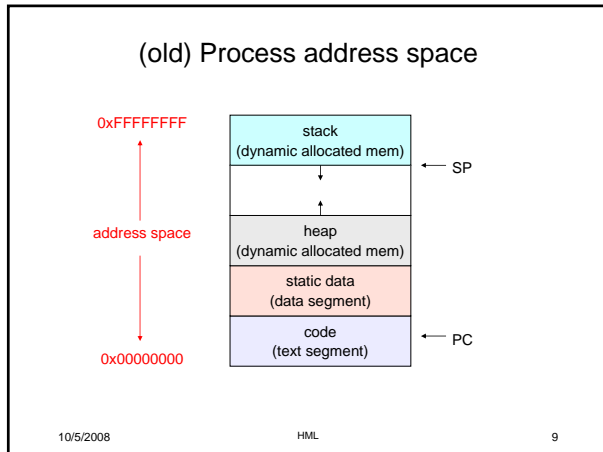

- ### Process/thread separation
- Concurrency (multithreading) is useful for:
    - handling concurrent events (e.g., web servers and clients)
    - building parallel programs (e.g., matrix multiply, ray tracing)
    - improving program structure (the Java argument)
  - Multithreading is useful even on a uniprocessor
    - even though only one thread can run at a time
  - Supporting multithreading – that is, separating the concept of a **process** (address space, files, etc.) from that of a minimal **thread of control** (execution state), is a big win
    - creating concurrency does not require creating new processes
    - “faster better cheaper”
- 10/5/2008 HML 11

- ### “Where do threads come from, Mommy?”
- Natural answer: the kernel is responsible for creating/managing threads
    - for example, the kernel call to create a new thread would
      - allocate an execution stack within the process address space
      - create and initialize a Thread Control Block
        - stack pointer, program counter, register values
      - stick it on the ready queue
    - we call these **kernel threads**
- 10/5/2008 HML 12

- Threads can also be managed at the user level (that is, entirely from within the process)
  - a library linked into the program manages the threads
    - because threads share the same address space, the thread manager doesn't need to manipulate address spaces (which only the kernel can do)
    - threads differ (roughly) only in hardware contexts (PC, SP, registers), which can be manipulated by user-level code
    - Thread package multiplexes user-level threads on top of kernel thread(s), which it treats as "virtual processors"
  - we call these **user-level threads**

10/5/2008

HML

13

### The design space

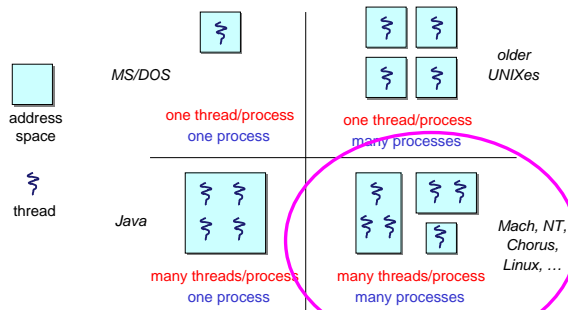

10/5/2008

HML

14

### Kernel threads

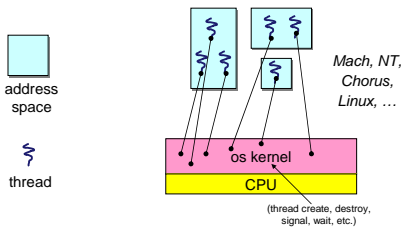

10/5/2008

HML

15

### User-level threads, conceptually

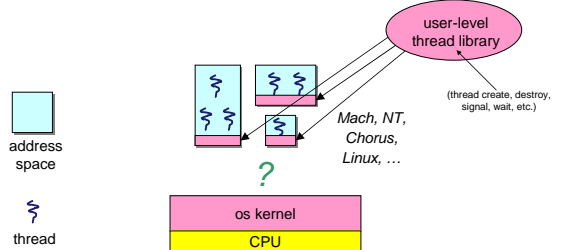

10/5/2008

HML

16

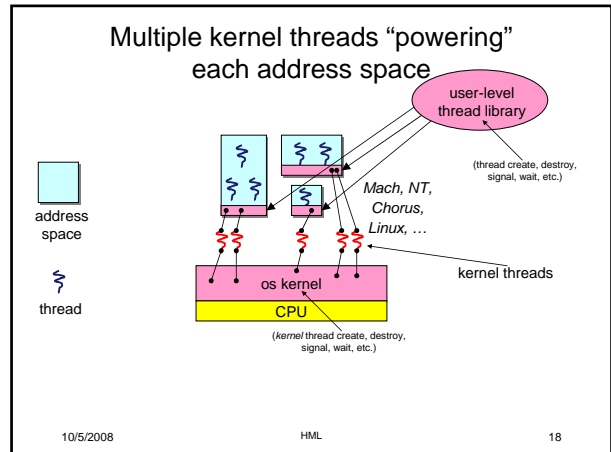
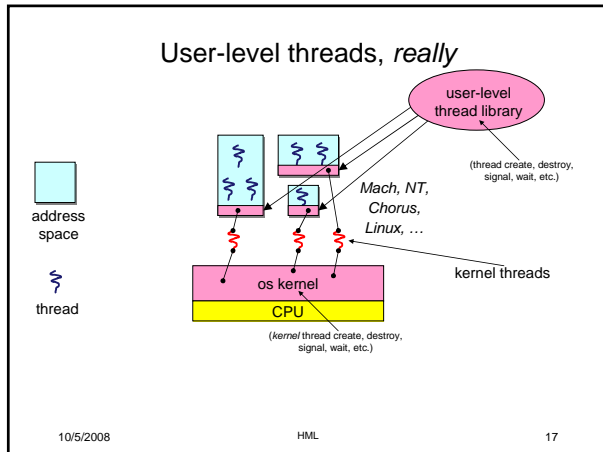

- ### Kernel threads
- OS now manages threads *and* processes
    - all thread operations are implemented in the kernel
    - OS schedules all of the threads in a system
      - if one thread in a process blocks (e.g., on I/O), the OS knows about it, and can run other threads from that process
      - possible to overlap I/O and computation *inside* a process
  - Kernel threads are cheaper than processes
    - less state to allocate and initialize
  - But, they're still pretty expensive for fine-grained use (e.g., orders of magnitude more expensive than a procedure call)
    - thread operations are all system calls
      - context switch
      - argument checks
    - must maintain kernel state for each thread
- 10/5/2008 HML 19

- ### User-level threads
- To make threads cheap and fast, they need to be implemented at the user level
    - managed entirely by user-level library, e.g. `libpthreads.a`
  - User-level threads are small and fast
    - each thread is represented simply by a PC, registers, a stack, and a small **thread control block** (TCB)
    - creating a thread, switching between threads, and synchronizing threads are done via procedure calls
      - no kernel involvement is necessary!
    - user-level thread operations can be 10-100x faster than kernel threads as a result
- 10/5/2008 HML 20

## Performance example

- On a 700MHz Pentium running Linux 2.2.16:
  - Processes
    - `fork/exit`: 251  $\mu$ s
  - Kernel threads
    - `pthread_create()/pthread_join()`: 94  $\mu$ s
  - User-level threads
    - `pthread_create()/pthread_join`: 4.5  $\mu$ s

10/5/2008

HML

21

## User-level thread implementation

- The kernel thread (the kernel-controlled executable entity associated with the address space) executes the code in the address space
- This code includes the thread support library and its associated thread scheduler
- The thread scheduler determines when a thread runs
  - it uses queues to keep track of what threads are doing: run, ready, wait
    - just like the OS and processes
    - but, implemented at user-level as a library

10/5/2008

HML

22

## Thread interface

- This is taken from the POSIX pthreads API:
  - `t = pthread_create(attributes, start_procedure)`
    - creates a new thread of control
    - new thread begins executing at `start_procedure`
  - `pthread_cond_wait(condition_variable)`
    - the calling thread blocks, sometimes called `thread_block()`
  - `pthread_signal(condition_variable)`
    - starts the thread waiting on the condition variable
  - `pthread_exit()`
    - terminates the calling thread
  - `pthread_wait(t)`
    - waits for the named thread to terminate

10/5/2008

HML

23

## How to keep a thread from hogging the CPU?

- Strategy 1: force everyone to cooperate
  - a thread willingly gives up the CPU by calling `yield()`
  - `yield()` calls into the scheduler, which context switches to another ready thread
  - what happens if a thread never calls `yield()`?
- Strategy 2: use preemption
  - scheduler requests that a timer interrupt be delivered by the OS periodically
    - usually delivered as a UNIX signal (man signal)
    - signals are just like software interrupts, but delivered to user-level by the OS instead of delivered to OS by hardware
  - at each timer interrupt, scheduler gains control and context switches as appropriate

10/5/2008

HML

24

## Thread context switch

- Very simple for user-level threads:
  - save context of currently running thread
    - push machine state onto thread stack
  - restore context of the next thread
    - pop machine state from next thread's stack
  - return as the new thread
    - execution resumes at PC of next thread
- This is all done by assembly language
  - it works at the level of the procedure calling convention
    - thus, it cannot be implemented using procedure calls

10/5/2008

HML

25

## What if a thread tries to do I/O?

- The kernel thread "powering" it is lost for the duration of the (synchronous) I/O operation!
- Could have one kernel thread "powering" each user-level thread
  - "common case" operations (e.g., synchronization) would be quick
- Could have a limited-size "pool" of kernel threads "powering" all the user-level threads in the address space
  - the kernel will be scheduling its threads obliviously to what's going on at user-level

10/5/2008

HML

26

## What if the kernel preempts a thread holding a lock?

- Other threads will be unable to enter the critical section and will block (stall)
  - tradeoff, as with everything else
- Solving this requires coordination between the kernel and the user-level thread manager
  - "scheduler activations"
    - a research paper from UW with huge effect on industry
    - each process can request one or more kernel threads
      - process is given responsibility for mapping user-level threads onto kernel threads
      - kernel promises to notify user-level before it suspends or destroys a kernel thread
    - ACM TOCS 10,1

10/5/2008

HML

27

## Summary

- You really want multiple threads per address space
- Kernel threads are much more efficient than processes, but they're still not cheap
  - all operations require a kernel call and parameter verification
- User-level threads are:
  - fast as blazes
  - great for common-case operations
    - creation, synchronization, destruction
  - can suffer in uncommon cases due to kernel obliviousness
    - I/O
    - preemption of a lock-holder
- Scheduler activations are the answer
  - pretty subtle though

10/5/2008

HML

28