

Matching in 2D

Readings: Ch. 11: Sec. 11.1-11.6

- alignment
- point representations and 2D transformations
- solving for 2D transformations from point correspondences
- some methodologies for alignment
 - local-feature-focus method
 - pose clustering
 - geometric hashing
- relational matching

Specific Object Recognition: Matching in 2D

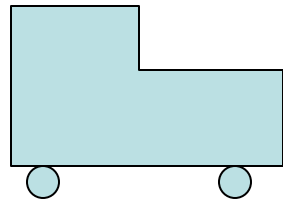

engine model

Is there an engine in the image?
If so, where is it located?

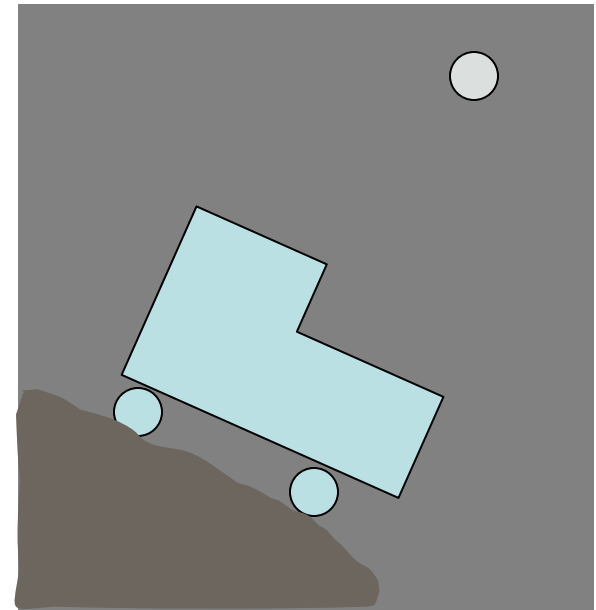
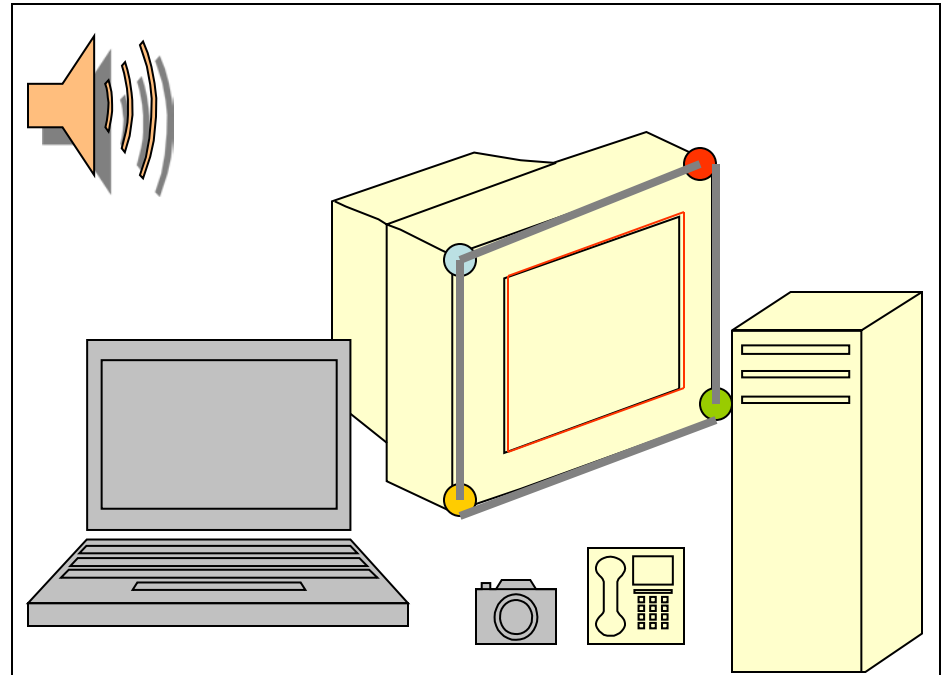
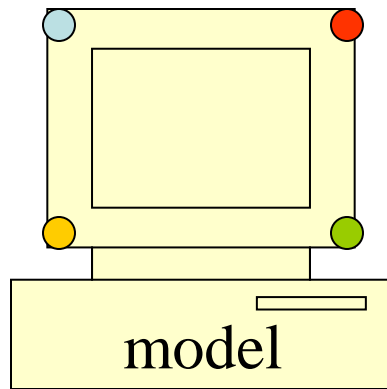

image containing an
instance of the model

Alignment

- Use a geometric feature-based model of the object.
- Match features of the object to features in the image.
- Produce a hypothesis h (matching features)
- Compute an affine transformation T from h
- Apply T to the features of the model to map the model features to the image.
- Use a verification procedure to decide how well the model features line up with actual image features

Alignment



image

How can the object in the image differ from that in the model?



Most often used:

2D Affine Transformations

1. translation

2. rotation

3. scale

4. skew

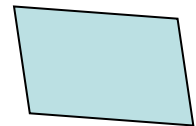
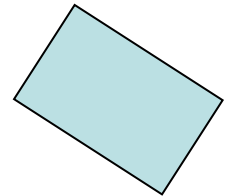

Point Representation and Transformations (review)

Normal Coordinates for a 2D Point

$$P = [x, y]^t = \begin{bmatrix} x \\ y \end{bmatrix}$$

Homogeneous Coordinates

$$P = [sx, sy, s]^t \text{ where } s \text{ is a scale factor}$$

Scaling

$$\begin{bmatrix} x \\ y \end{bmatrix} = \begin{bmatrix} c_x & 0 \\ 0 & c_y \end{bmatrix} \begin{bmatrix} x \\ y \end{bmatrix} = \begin{bmatrix} c_x * x \\ c_y * y \end{bmatrix}$$

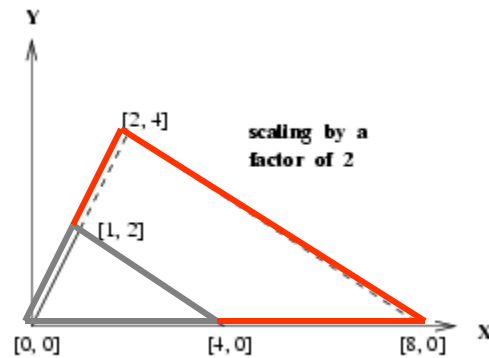

scaling by
a factor of 2
about (0,0)

Rotation

$$\begin{bmatrix} x \\ y \end{bmatrix} = \begin{bmatrix} \cos \theta & -\sin \theta \\ \sin \theta & \cos \theta \end{bmatrix} \begin{bmatrix} x \\ y \end{bmatrix} = \begin{bmatrix} x \cos \theta - y \sin \theta \\ x \sin \theta + y \cos \theta \end{bmatrix}$$

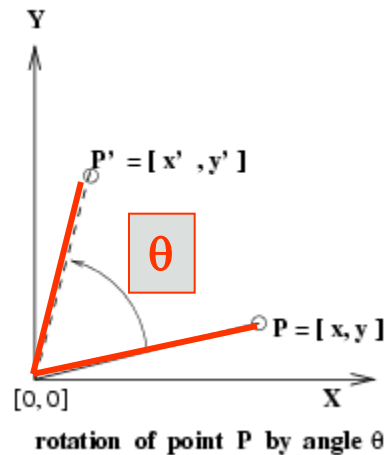

rotate point

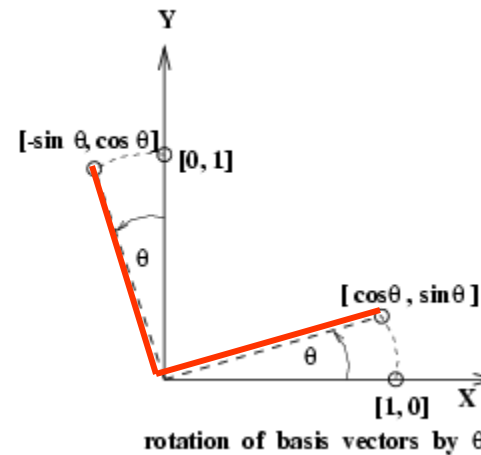

rotate axes

Translation

2 X 2 matrix doesn't work for translation!
Here's where we need homogeneous coordinates.

$$\begin{pmatrix} x \\ y \\ 1 \end{pmatrix} = \begin{pmatrix} 1 & 0 & x_0 \\ 0 & 1 & y_0 \\ 0 & 0 & 1 \end{pmatrix} \begin{pmatrix} x \\ y \\ 1 \end{pmatrix} = \begin{pmatrix} x + x_0 \\ y + y_0 \\ 1 \end{pmatrix}$$

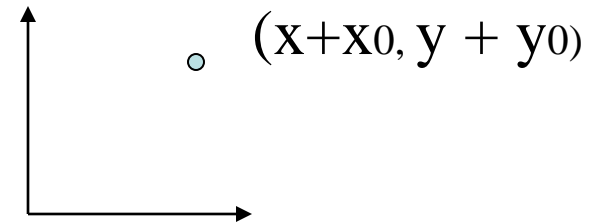
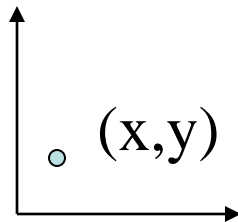

Rotation, Scaling and Translation

$$\begin{pmatrix} x_w \\ y_w \\ 1 \end{pmatrix} = \begin{pmatrix} 1 & 0 & x_0 \\ 0 & 1 & y_0 \\ 0 & 0 & 1 \end{pmatrix} \begin{pmatrix} s & 0 & 0 \\ 0 & s & 0 \\ 0 & 0 & 1 \end{pmatrix} \begin{pmatrix} \cos \theta & -\sin \theta & 0 \\ \sin \theta & \cos \theta & 0 \\ 0 & 0 & 1 \end{pmatrix} \begin{pmatrix} x_i \\ y_i \\ 1 \end{pmatrix}$$

T S R

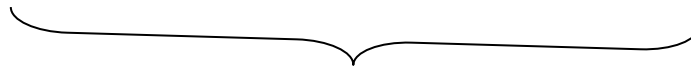

T_R

2D Model and 3 Matching Images of a Boeing Airplane Part

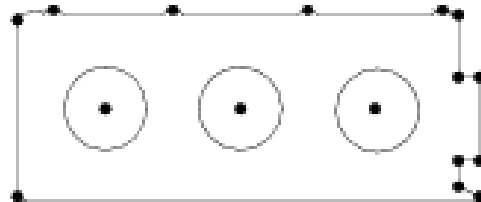

a) Part Model

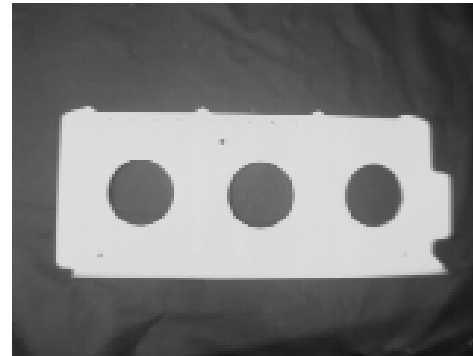

b) Horizontal Image

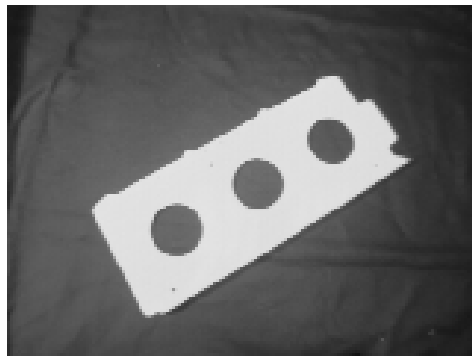

c) Rotated Image



d) Rotated and Skewed Image

Computing Affine Transformations between Sets of Matching Points

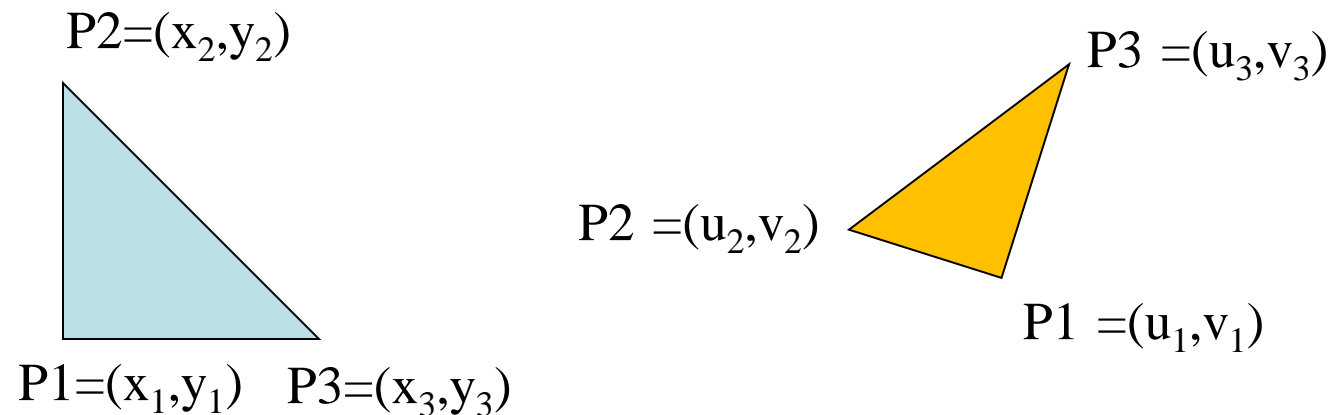

Given 3 matching pairs of points, the affine transformation can be computed through solving a simple matrix equation.

$$\begin{pmatrix} u_1 & u_2 & u_3 \\ v_1 & v_2 & v_3 \\ 1 & 1 & 1 \end{pmatrix} = \begin{pmatrix} a_{11} & a_{12} & a_{13} \\ a_{21} & a_{22} & a_{23} \\ 0 & 0 & 1 \end{pmatrix} \begin{pmatrix} x_1 & x_2 & x_3 \\ y_1 & y_2 & y_3 \\ 1 & 1 & 1 \end{pmatrix}$$

A More Robust Approach

Using only 3 points is dangerous, because if even one is off, the transformation can be far from correct.

Instead, use many (**n = 10 or more**) pairs of matching control points to determine a **least squares estimate** of the six parameters of the affine transformation.

$$\text{Error}(a_{11}, a_{12}, a_{13}, a_{21}, a_{22}, a_{23}) =$$

$$\sum_{j=1, n} \left((a_{11} * x_j + a_{12} * y_j + a_{13} - u_j)^2 + (a_{21} * x_j + a_{22} * y_j + a_{23} - v_j)^2 \right)$$

The Equations to Solve

$$\varepsilon(a_{11}, a_{12}, a_{13}, a_{21}, a_{22}, a_{23}) = \sum_{j=1}^n ((a_{11}x_j + a_{12}y_j + a_{13} - u_j)^2 + (a_{21}x_j + a_{22}y_j + a_{23} - v_j)^2) \quad (11.16)$$

Taking the six partial derivatives of the error function with respect to each of the six variables and setting this expression to zero gives us the six equations represented in matrix form in Equation 11.17 .

$$\begin{bmatrix} \Sigma x_j^2 & \Sigma x_j y_j & \Sigma x_j & 0 & 0 & 0 \\ \Sigma x_j y_j & \Sigma y_j^2 & \Sigma y_j & 0 & 0 & 0 \\ \Sigma x_j & \Sigma y_j & \Sigma 1 & 0 & 0 & 0 \\ 0 & 0 & 0 & \Sigma x_j^2 & \Sigma x_j y_j & \Sigma x_j \\ 0 & 0 & 0 & \Sigma x_j y_j & \Sigma y_j^2 & \Sigma y_j \\ 0 & 0 & 0 & \Sigma x_j & \Sigma y_j & \Sigma 1 \end{bmatrix} \begin{bmatrix} a_{11} \\ a_{12} \\ a_{13} \\ a_{21} \\ a_{22} \\ a_{23} \end{bmatrix} = \begin{bmatrix} \Sigma u_j x_j \\ \Sigma u_j y_j \\ \Sigma u_j \\ \Sigma v_j x_j \\ \Sigma v_j y_j \\ \Sigma v_j \end{bmatrix} \quad (11.17)$$

What is this for?

Many 2D matching techniques use it.

1. Local-Feature Focus Method
2. Pose Clustering
3. Geometric Hashing

Local-Feature-Focus Method

- Each model has a set of features (interesting points).
 - The focus features are the particularly detectable features, usually representing several different areas of the model.
 - Each focus feature has a set of nearby features that can be used, along with the focus feature, to compute the transformation.

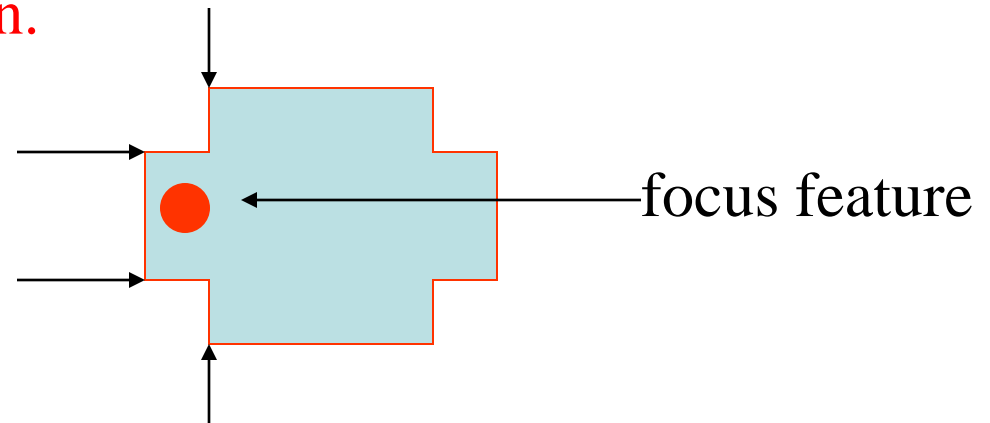

LFF Algorithm

Let G be the set of detected image features.

Let F_m be focus features of the model.

Let $S(f)$ be the nearby features for feature f .

for each focus feature F_m

for each image feature G_i of the same type as F_m

1. **find the maximal subgraph** S_m of $S(F_m)$ that matches a subgraph S_i of $S(G_i)$.
2. **Compute transformation** T that maps the points of each feature of S_m to the corresponding one of S_i .
3. **Apply T to the line segments** of the model.
4. If enough transformed segments find **evidence in the image**, return(T)

Example Match 1: Good Match

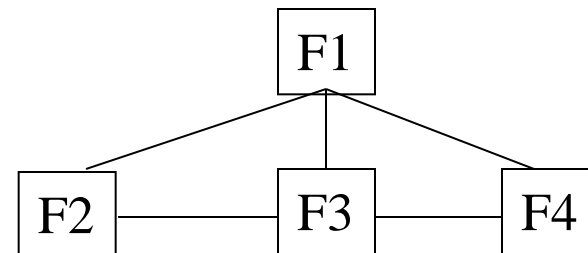
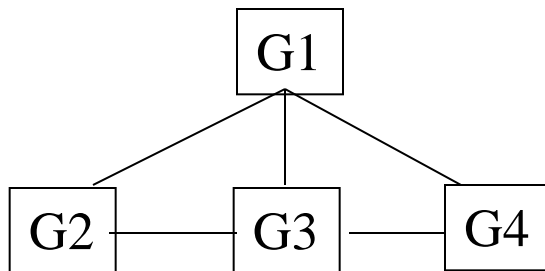
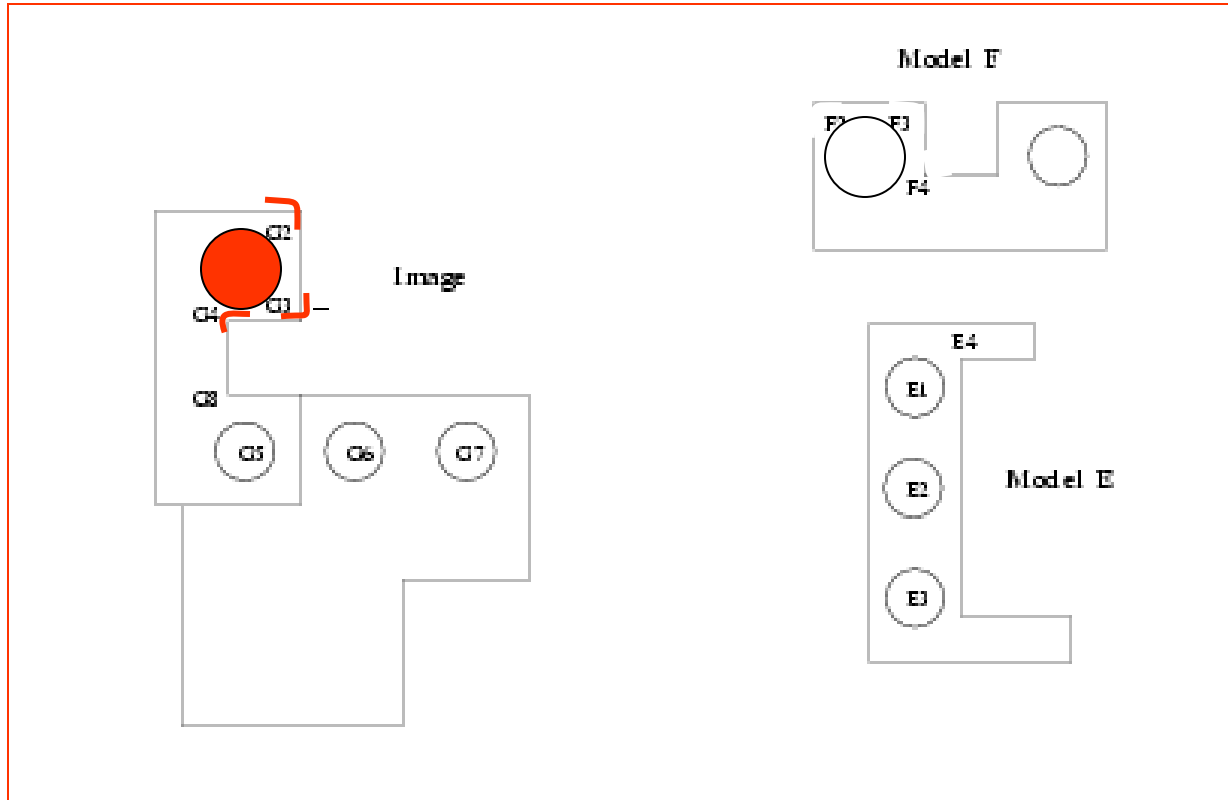

Example Match 2: Poor Match

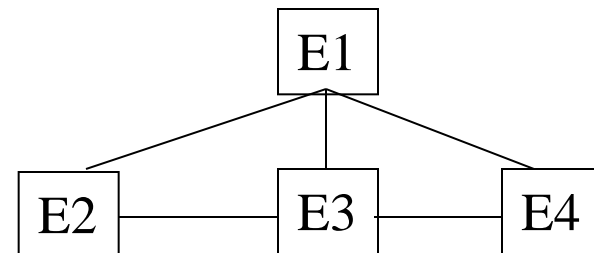
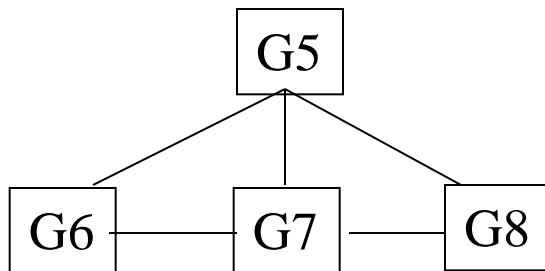
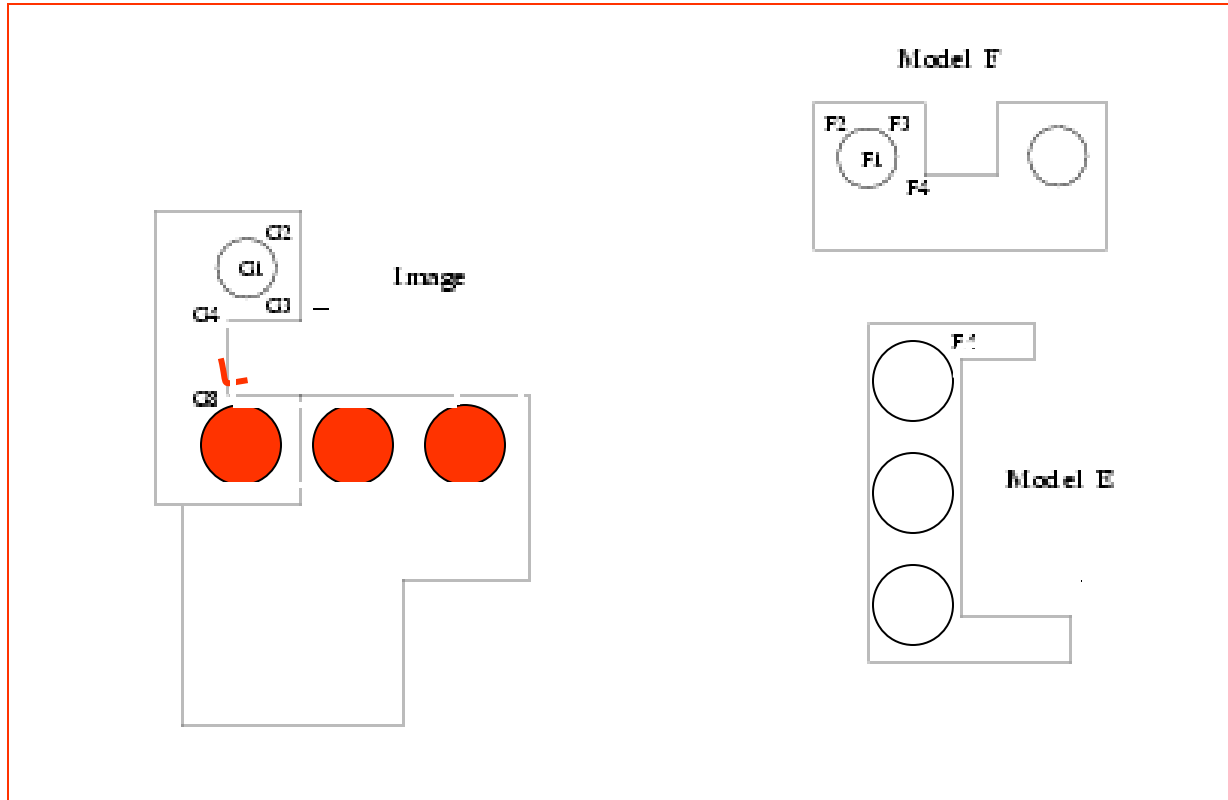

Pose Clustering

Let T be a transformation aligning model M with image object O

The **pose** of object O is its location and orientation, **defined by T** .

The idea of pose clustering is to **compute lots of possible pose transformations**, each based on 2 points from the model and 2 hypothesized corresponding points from the image.*

Then **cluster all the transformations** in pose space and try to **verify** the large clusters.

* This is not a full affine transformation, just RST.

Pose Clustering

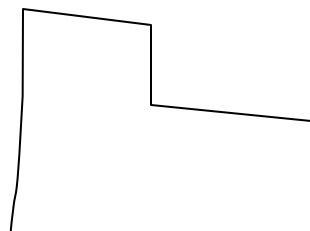

Model

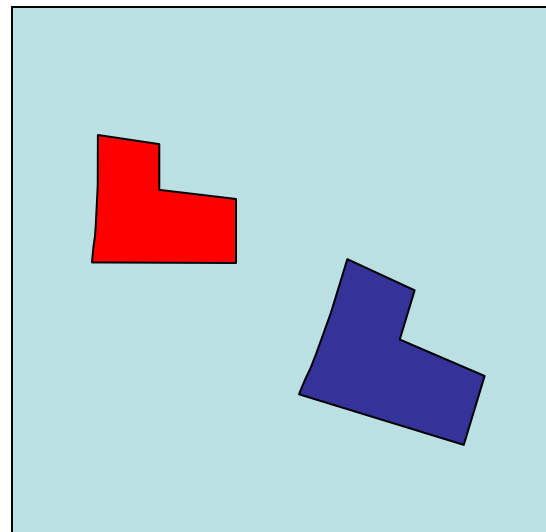

Image

Pose Clustering

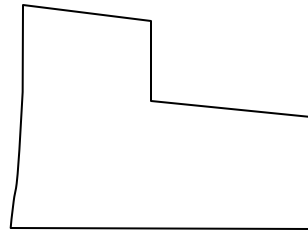

Model

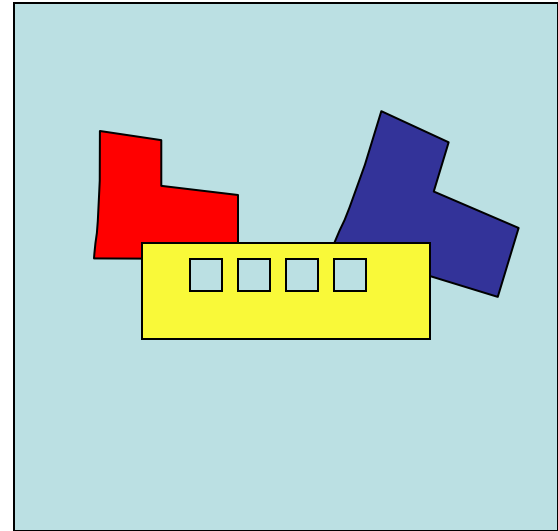

Image

Pose Clustering Applied to Detecting a Particular Airplane

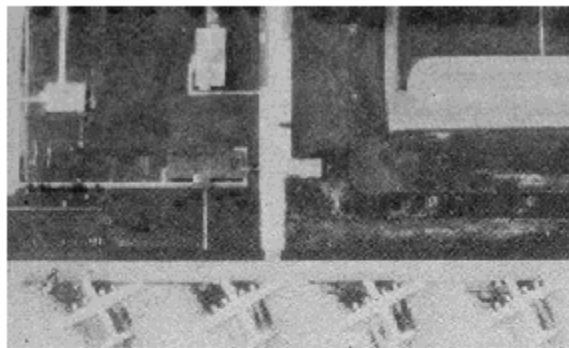

(a) original airfield image

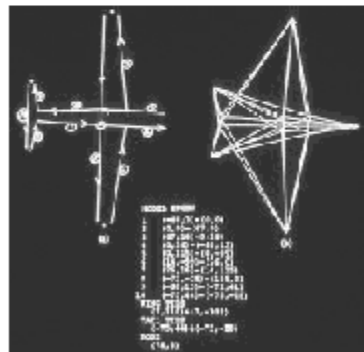

(b) model of object

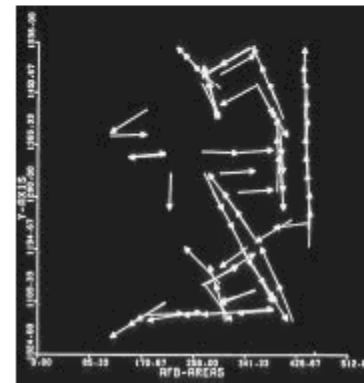

(c) detections matching model

Geometric Hashing

- This method was developed for the case where there is a **whole database of models** to try to find in an image.
- It trades:
 - a large amount of offline preprocessing and
 - a large amount of space
- for potentially fast online
 - object recognition**
 - pose detection**

Theory Behind Geometric Hashing

- A **model M** is a an ordered set of feature points.

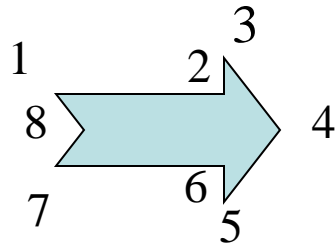

$$M = \langle P_1, P_2, P_3, P_4, P_5, P_6, P_7, P_8 \rangle$$

- An **affine basis** is any subset $E = \{e_{00}, e_{01}, e_{10}\}$ of noncollinear points of **M**.
- For basis E , any point $x \in M$ can be represented in **affine coordinates** (ξ, η) .

$$x = \xi(e_{10} - e_{00}) + \eta(e_{01} - e_{00}) + e_{00}$$

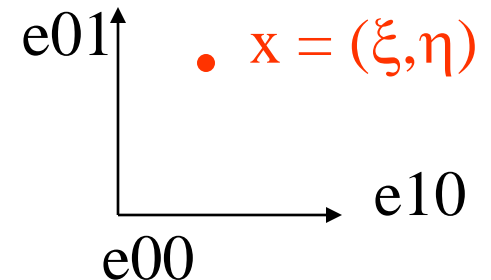

Affine Transform

If x is represented in affine coordinates (ξ, η) .

$$\mathbf{x} = \xi(\mathbf{e}_{10} - \mathbf{e}_{00}) + \eta(\mathbf{e}_{01} - \mathbf{e}_{00}) + \mathbf{e}_{00}$$

and we apply affine transform T to point x , we get

$$T\mathbf{x} = \xi(T\mathbf{e}_{10} - T\mathbf{e}_{00}) + \eta(T\mathbf{e}_{01} - T\mathbf{e}_{00}) + T\mathbf{e}_{00}$$

In both cases, x has the same coordinates (ξ, η) .

Example

original object

transformed object

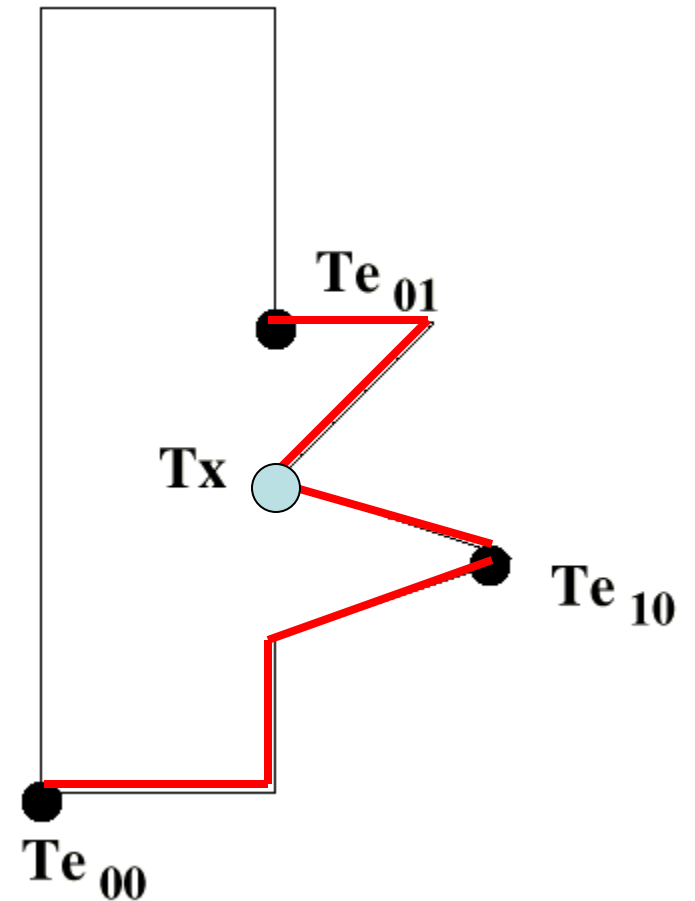
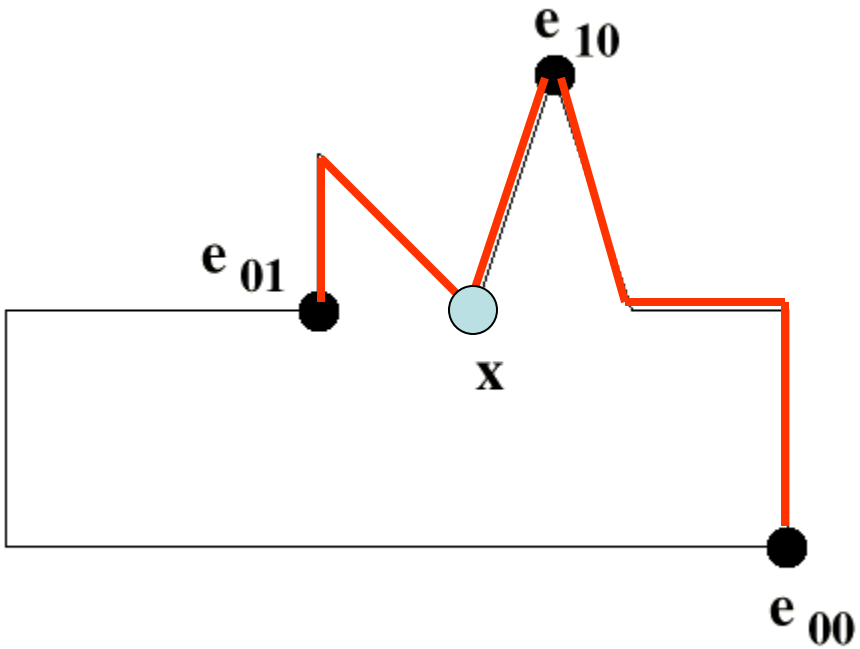

Offline Preprocessing

For each model M

{

 Extract feature point set FM

 for each noncollinear triple E of FM (**basis**)

 for each **other point** x of FM

 {

calculate (ξ, η) for x with respect to E

store (M,E) in hash table H at index (ξ, η)

 }

 }

Hash Table

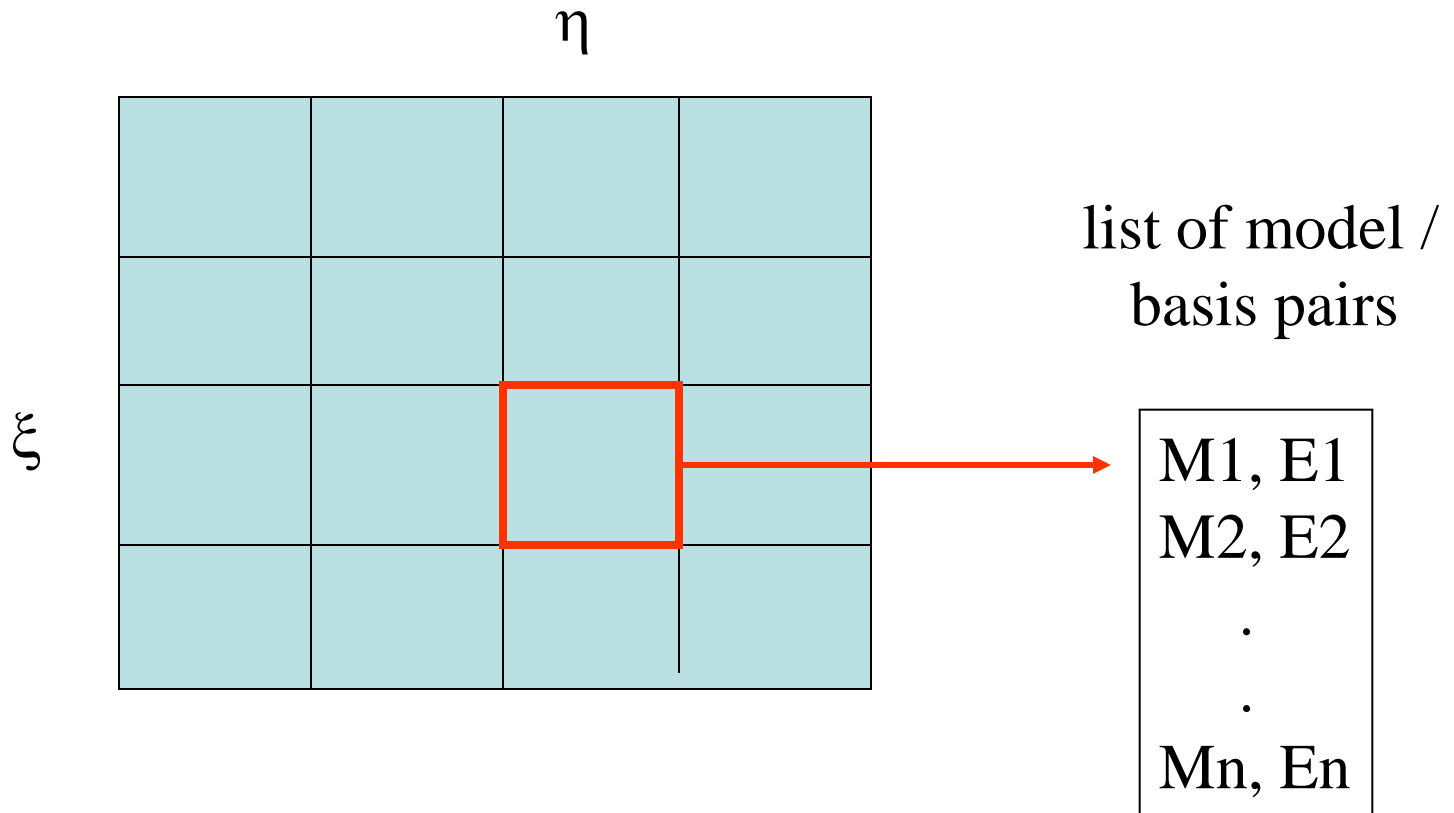

Online Recognition

initialize accumulator A to all zero
extract feature points from image

```
for each basis triple  $F$  /* one basis */
  for each other point  $v$  /* each image point */
    {
      calculate  $(\xi, \eta)$  for  $v$  with respect to  $F$ 
      retrieve list  $L$  from hash table at index  $(\xi, \eta)$ 
      for each pair  $(M, E)$  of  $L$ 
         $A[M, E] = A[M, E] + 1$ 
    }
```

find peaks in accumulator array A

for each peak (M, E) in A

calculate and try to **verify** $T \ni: F = TE$

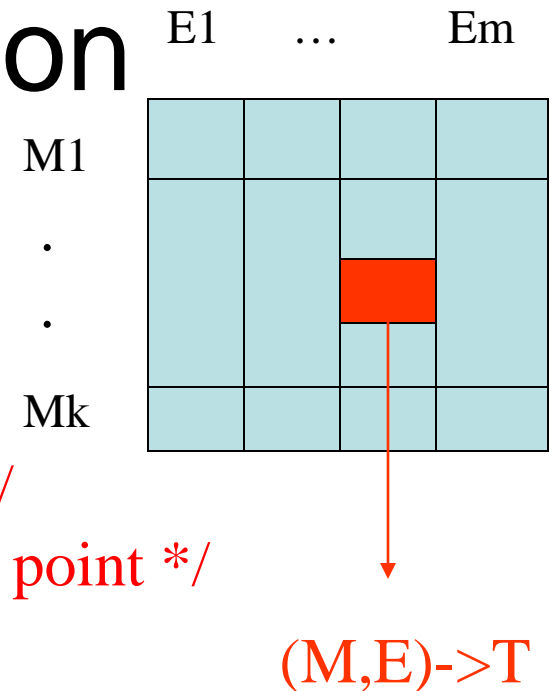

Robotics Example (MIT)

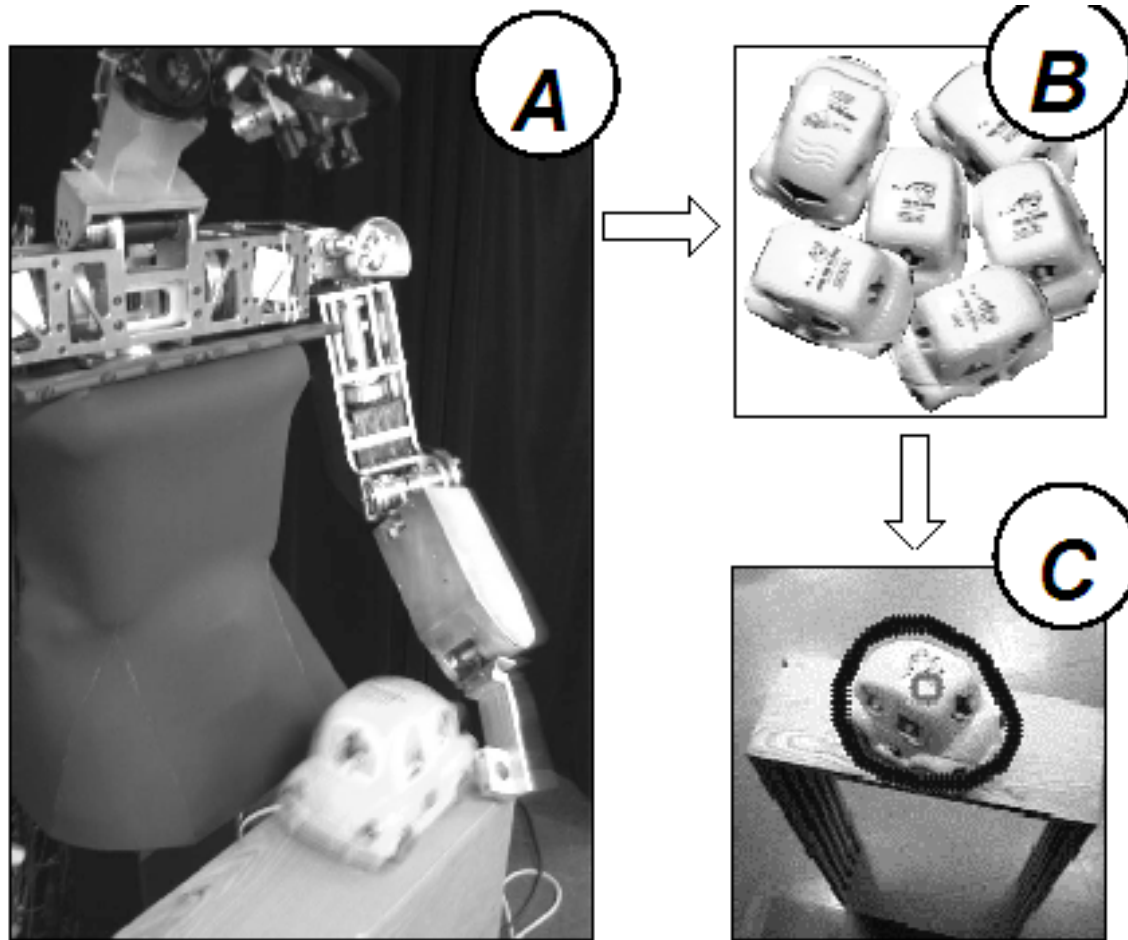

Molecular Biology Example

Tel Aviv University

Protein Matching

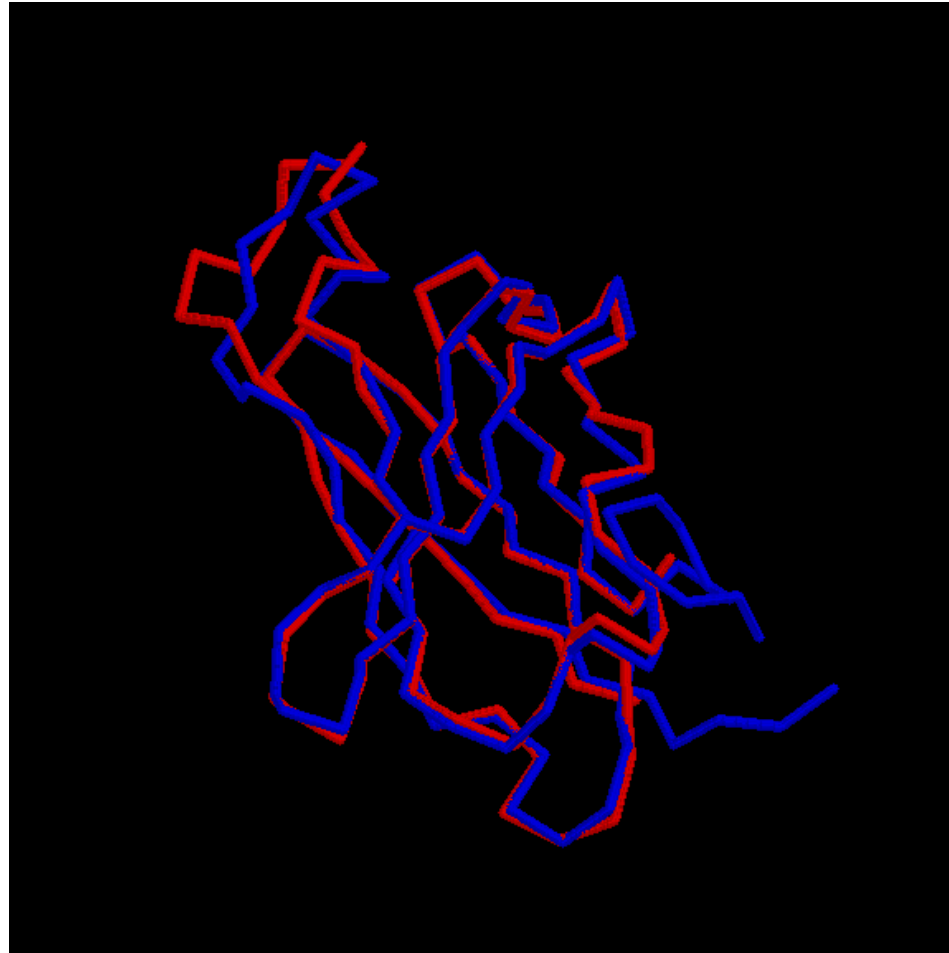

Verification

How well does the transformed model line up with the image.

- compare positions of feature points
- compare full line or curve segments

Whole segments work better, allow less **halucination**, but there's a higher cost in execution time.

2D Matching Mechanisms

- We can **formalize the recognition problem** as finding a mapping from model structures to image structures.
- Then we can look at different paradigms for solving it.
 - interpretation tree search
 - discrete relaxation
 - relational distance
 - continuous relaxation

Formalism

- A **part** (unit) is a structure in the scene, such as a region or segment or corner.
- A **label** is a symbol assigned to identify the part.
- An **N-ary relation** is a set of N-tuples defined over a set of parts or a set of labels.
- An **assignment** is a mapping from parts to labels.

Example

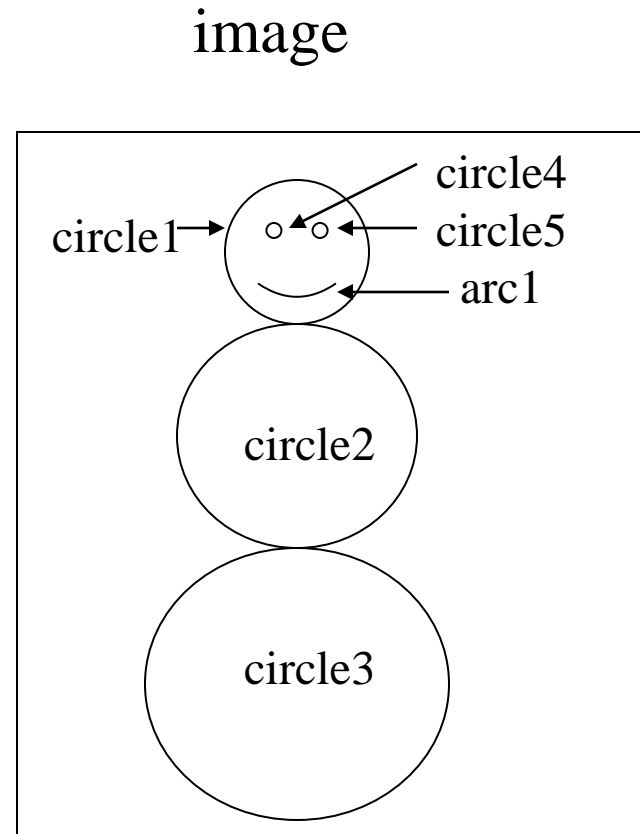
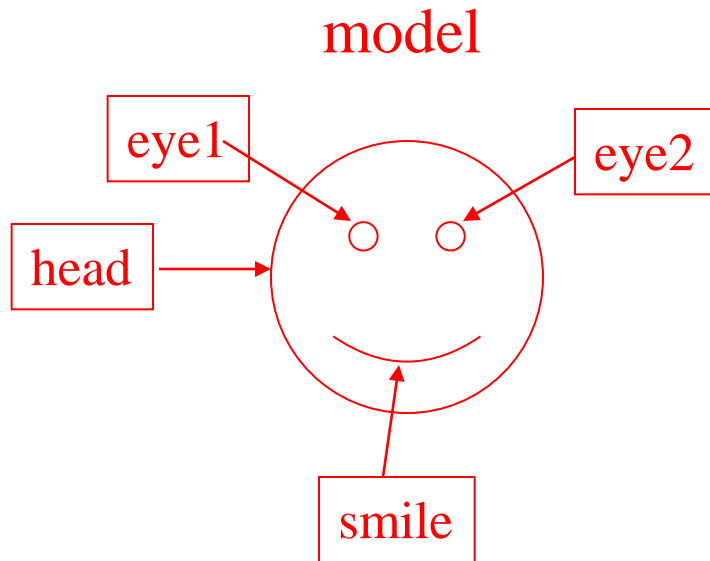

What are the relationships?

What is the best assignment
of model labels to image features?

Consistent Labeling Definition

Given:

1. a set of units P
2. a set of labels for those units L
3. a relation R_P over set P
4. a relation R_L over set L

A consistent labeling f is a mapping $f: P \rightarrow L$ satisfying

if $(p_i, p_j) \in R_P$, then $(f(p_i), f(p_j)) \in R_L$

which means that a consistent labeling preserves relationships.

Abstract Example

binary relation R_P

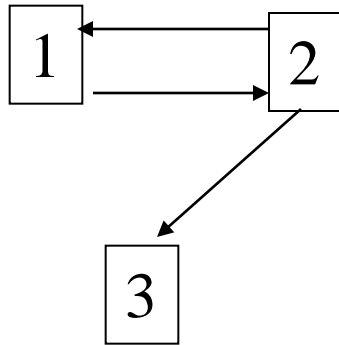

$$P = \{1, 2, 3\}$$

$$R_P = \{(1, 2), (2, 1), (2, 3)\}$$

binary relation R_L

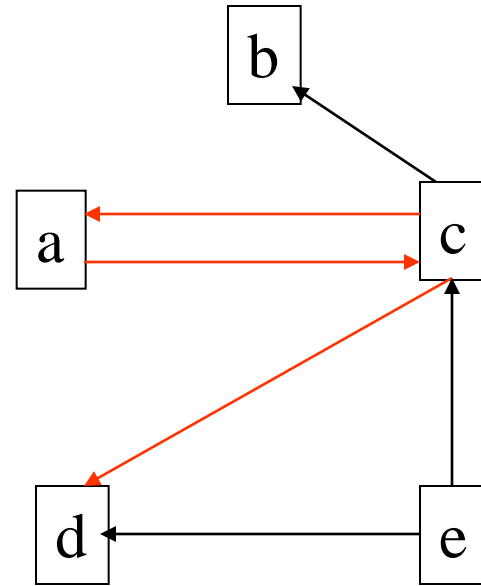

$$L = \{a, b, c, d, e\}$$

$$R_L = \{(a, c), (c, a), (c, b), \\ (c, d), (e, c), (e, d)\}$$

One consistent labeling is $\{(1, a), (2, c), (3, d)\}$

House Example

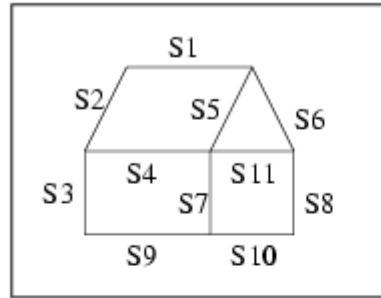

Image 1 **P**

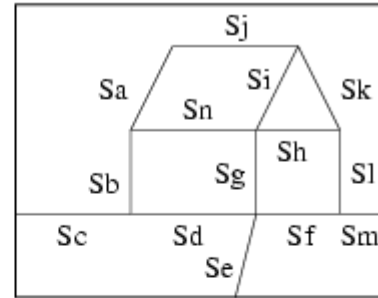

Image 2 **L**

$$P = \{S1, S2, S3, S4, S5, S6, S7, S8, S9, S10, S11\}.$$

$$L = \{Sa, Sb, Sc, Sd, Se, Sf, Sg, Sh, Si, Sj, Sk, Sl, Sm\}.$$

$$R_P = \{ (S1, S2), (S1, S5), (S1, S6), (S2, S3), (S2, S4), (S3, S4), (S3, S9), (S4, S5), (S4, S7), (S4, S11), (S5, S6), (S5, S7), (S5, S11), (S6, S8), (S6, S11), (S7, S9), (S7, S10), (S7, S11), (S8, S10), (S8, S11), (S9, S10) \}.$$

$$R_L = \{ (Sa, Sb), (Sa, Sj), (Sa, Sn), (Sb, Sc), (Sb, Sd), (Sb, Sn), (Sc, Sd), (Sd, Se), (Sd, Sf), (Sd, Sg), (Se, Sf), (Se, Sg), (Sf, Sg), (Sf, Sl), (Sf, Sm), (Sg, Sh), (Sg, Si), (Sg, Sn), (Sh, Si), (Sh, Sk), (Sh, Sl), (Sh, Sn), (Si, Sj), (Si, Sk), (Si, Sn), (Sj, Sk), (Sk, Sl), (Sl, Sm) \}.$$

RP and RL are connection relations.

$$f(S1) = S_j$$

$$f(S4) = S_n$$

$$f(S7) = S_g$$

$$f(S10) = S_f$$

$$f(S2) = S_a$$

$$f(S5) = S_i$$

$$f(S8) = S_l$$

$$f(S11) = S_h$$

$$f(S3) = S_b$$

$$f(S6) = S_k$$

$$f(S9) = S_d$$

1. Interpretation Tree

- An **interpretation tree** is a tree that represents all assignments of labels to parts.
- Each path from the root node to a leaf represents a (partial) assignment of labels to parts.
- Every path terminates as either
 1. a complete consistent labeling
 2. a failed partial assignment

Interpretation Tree Example

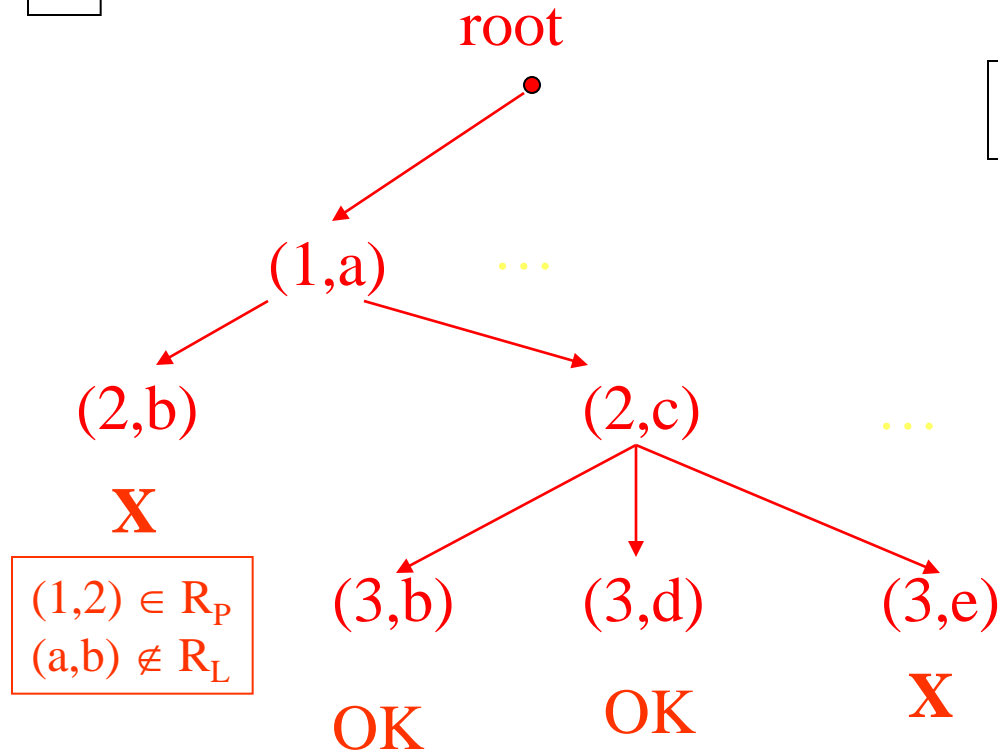
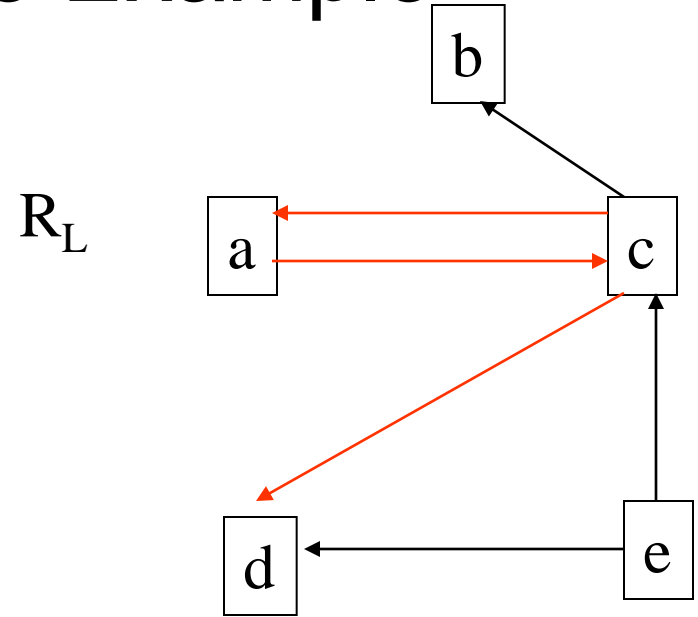
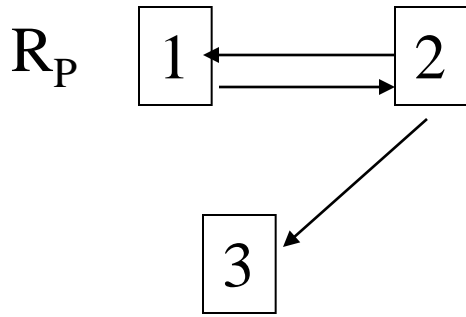

2. Discrete Relaxation

- Discrete relaxation is an alternative to (or addition to) the interpretation tree search.
- Relaxation is an iterative technique with polynomial time complexity.
- Relaxation uses local constraints at each iteration.
- It can be implemented on parallel machines.

How Discrete Relaxation Works

1. Each unit is assigned a set of **initial possible labels**.
2. **All relations are checked to see if some pairs of labels are impossible for certain pairs of units.**
3. **Inconsistent labels are removed** from the label sets.
4. If any labels have been filtered out then another pass is executed else the relaxation part is done.
5. If there is more than one labeling left, a tree search can be used to find each of them.

Example of Discrete Relaxation

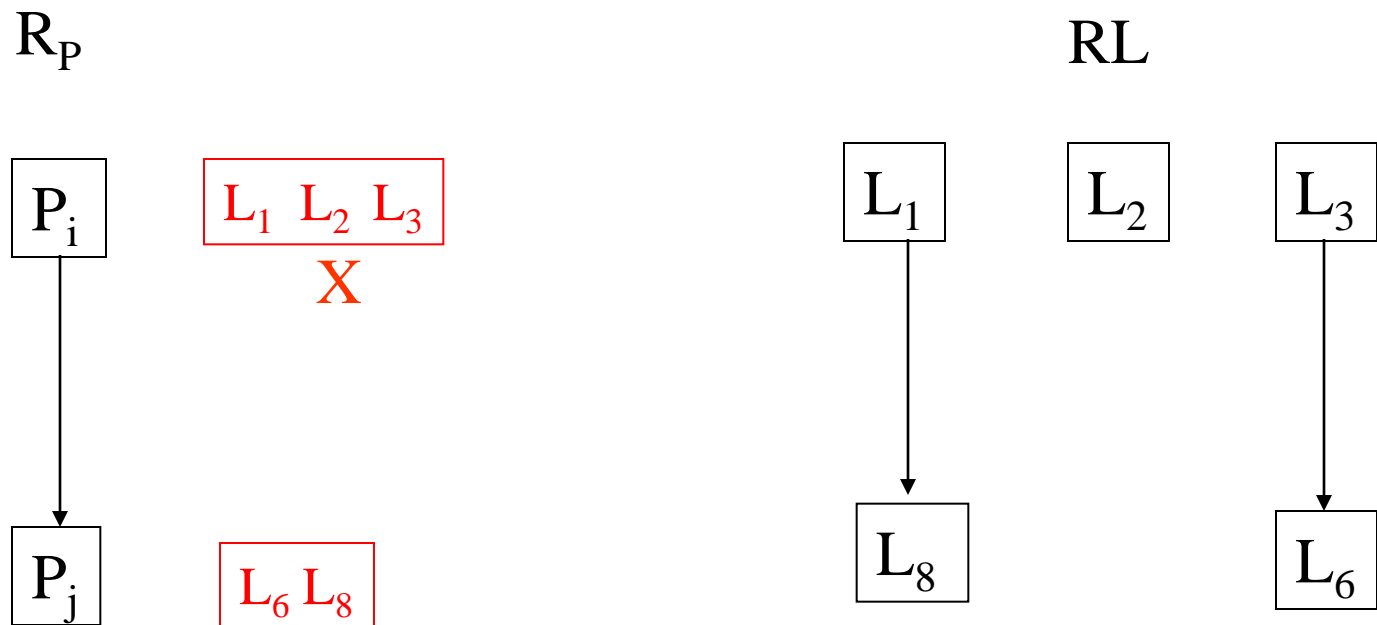

There is no label in P_j 's label set that is connected to L_2 in P_i 's label set. L_2 is inconsistent and filtered out.

3. Relational Distance Matching

- A fully consistent labeling is unrealistic.
- An image may have missing and extra features; required relationships may not always hold.
- Instead of looking for a consistent labeling, we can look for the **best mapping from P to L**, the one that preserves the most relationships.

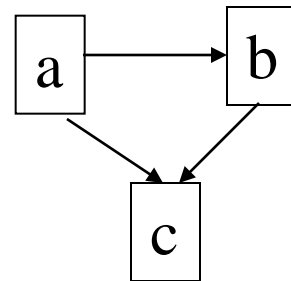
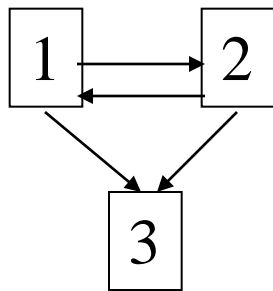

Preliminary Definitions

Def: A **relational description** D_P is a sequence of relations over a set of primitives P .

- Let $D_A = \{R_1, \dots, R_I\}$ be a relational description over A .
- Let $D_B = \{S_1, \dots, S_I\}$ be a relational description over B .
- Let f be a 1-1, onto mapping from A to B .
- For any relation R , the composition **$R \circ f$** is given by

$$R \circ f = \{(b_1, \dots, b_n) \mid (a_1, \dots, a_n) \text{ is in } R \text{ and } f(a_i) = (b_i), i=1, n\}$$

Example of Composition

$$R \circ f = \{(b_1, \dots, b_n) \mid (a_1, \dots, a_n) \text{ is in } R \text{ and } f(a_i) = (b_i), i=1, n\}$$

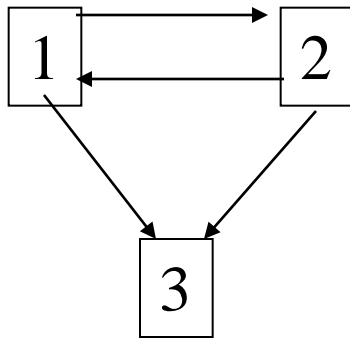

R

1	a
2	b
3	c

f

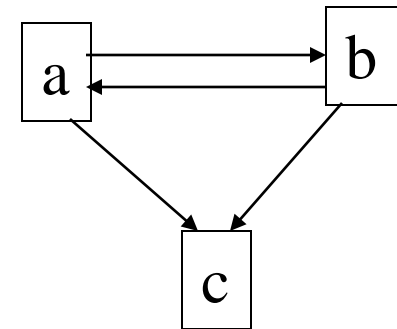

$R \circ f$

$R \circ f$ is an isomorphic copy of R with nodes renamed by f.

Relational Distance Definition

Let D_A be a relational description over set A ,
 D_B be a relational description over set B ,
and $f : A \rightarrow B$.

- The **structural error of f** for R_i in D_A and S_i in D_B is

$$E_S^i(f) = |R_i \circ f - S_i| + |S_i \circ f^{-1} - R_i|$$

- The **total error of f** with respect to D_A and D_B is

$$E(f) = \sum_{i=1}^I E_S^i(f)$$

- The **relational distance** $GD(DA, DB)$ is given by

$$GD(DA, DB) = \min_{f : A \rightarrow B, f \text{ is 1-1 and onto}} E(f)$$

Example

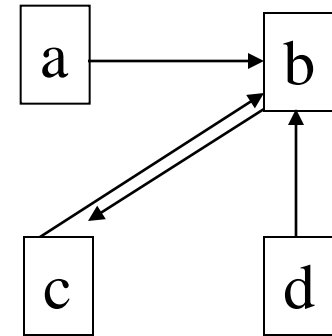
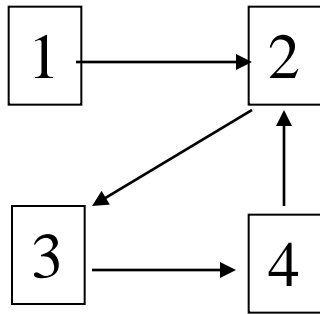

What is the best mapping?

What is the error of the best mapping?

Example

Let $f = \{(1,a),(2,b),(3,c),(4,d)\}$

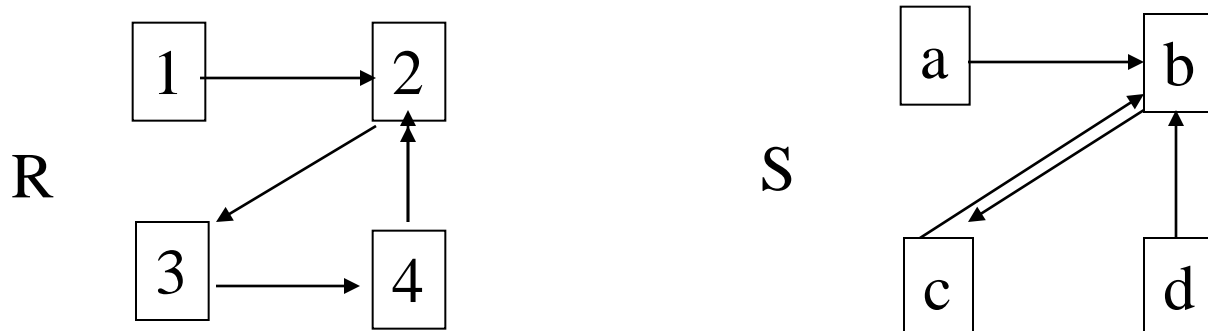

$$\begin{aligned} |R \circ f - S| &= |\{(a,b)(b,c)(c,d)(d,b)\} - \{(a,b)(b,c)(c,b)(d,b)\}| \\ &= |\{(c,d)\}| = 1 \end{aligned}$$

$$\begin{aligned} |S \circ f^{-1} - R| &= |\{(1,2)(2,3)(3,2)(4,2)\} - \{(1,2)(2,3)(3,4)(4,2)\}| \\ &= |\{(3,2)\}| = 1 \end{aligned}$$

$$E(f) = 1+1 = 2$$

Is there a better mapping?

Example of a Cluster of Sticks-Plates-Blobs Objects

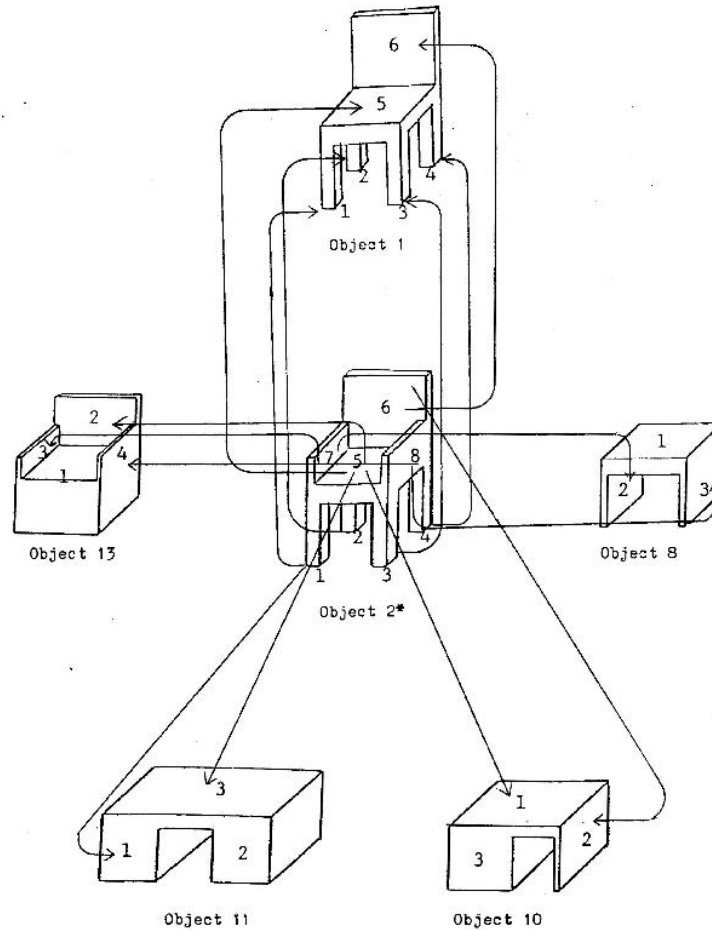

Variations

- Different weights on different relations
- Normalize error by dividing by total possible
- Attributed relational distance for attributed relations
- Penalizing for NIL mappings

Implementation

- Relational distance requires finding the lowest cost mapping from object features to image features.
- It is typically done using a branch and bound tree search.
- The search keeps track of the error after each object part is assigned an image feature.
- When the error becomes higher than the best mapping found so far, it backs up.
- It can also use discrete relaxation or forward checking (see Russel AI book on Constraint Satisfaction) to prune the search.

4. Continuous Relaxation

- In discrete relaxation, a label for a unit is either possible or not.
- In continuous relaxation, each (unit, label) pair has a probability.
- Every label for unit i has a prior probability.
- A set of compatibility coefficients $C = \{c_{ij}\}$ gives the influence that the label of unit i has on the label of unit j .
- The relationship R is replaced by a set of unit/label compatibilities where $r_{ij}(l, l')$ is the compatibility of label l for part i with label l' for part j .
- An iterative process updates the probability of each label for each unit in terms of its previous probability and the compatibilities of its current labels and those of other units that influence it.

Summary

- 2D object recognition for specific objects (usually industrial) is done by alignment.
 - Affine transformations are usually powerful enough to handle objects that are mainly two-dimensional.
 - Matching can be performed by many different “graph-matching” methodologies.
 - Verification is a necessary part of the procedure.
- Appearance-based recognition is another 2D recognition paradigm that came from the need for recognizing specific instances of a general object class, motivated by face recognition.
- Parts-based recognition combines appearance-based recognition with interest-region detection. It has been used to recognize multiple generic object classes.