

Hierarchical Modeling

**Brian Curless
CSE 457
Spring 2013**

Reading

Required:

- ◆ Angel, sections 8.1 – 8.6, 8.8

Optional:

- ◆ *OpenGL Programming Guide*, chapter 3

Symbols and instances

Most graphics APIs support a few geometric primitives:

- ◆ spheres
- ◆ cubes
- ◆ cylinders

`gluSphere()`

These symbols are **instanced** using an **instance transformation**.

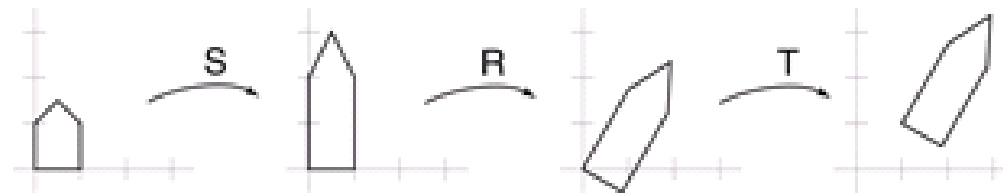

Q: What is the matrix for the instance transformation above?

$$M = T R S$$

3D Example: A robot arm

Consider this robot arm with 3 degrees of freedom:

- Base rotates about its vertical axis by θ
- Upper arm rotates in its xy -plane by ϕ
- Lower arm rotates in its xy -plane by ψ

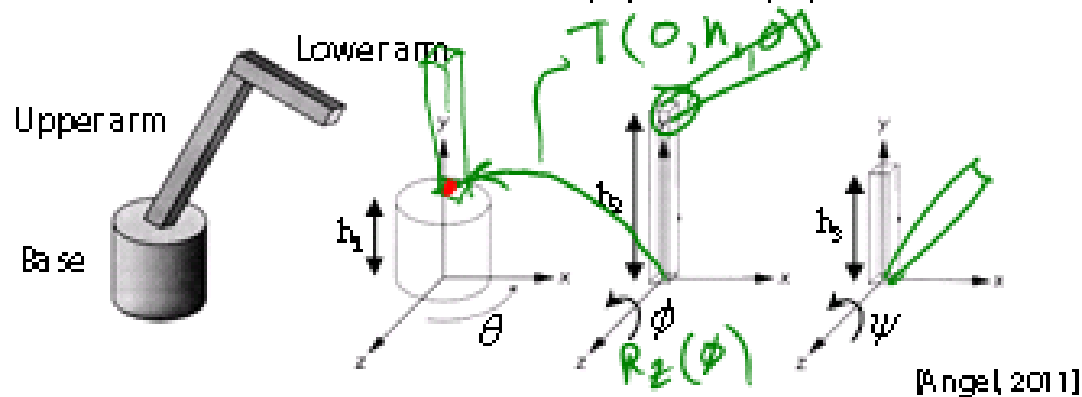

$$R_x(\)$$

$$R_y(\)$$

$$R_z(\)$$

$$T(\)$$

(Note that the angles are set to zero in the figure; i.e., the parts are shown in their "default" positions.)

Q: What matrix do we use to transform the base?

Q: What matrix for the upper arm?

Q: What matrix for the lower arm?

$$\underbrace{R_y(\theta)}_{\text{base}} \underbrace{T(0, h_1, 0) R_z(\phi)}_{\text{upper arm}} \underbrace{T(0, h_2, 0) R_z(\psi)}_{\text{lower arm}}$$

3D Example: A robot arm

An alternative interpretation is that we are taking the original coordinate frames...

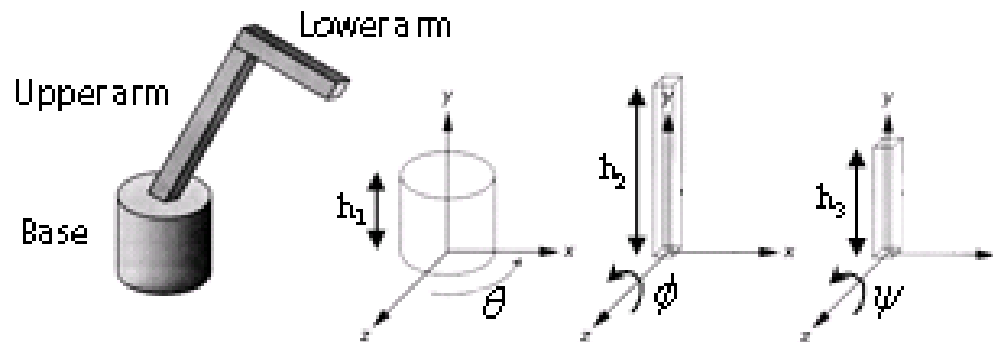

...and translating and rotating them into place:

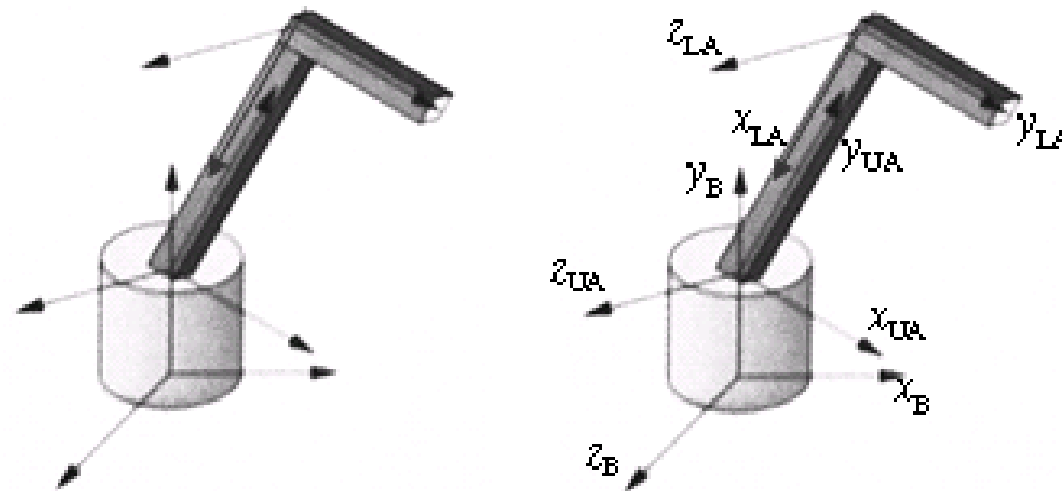

From parts to model to viewer

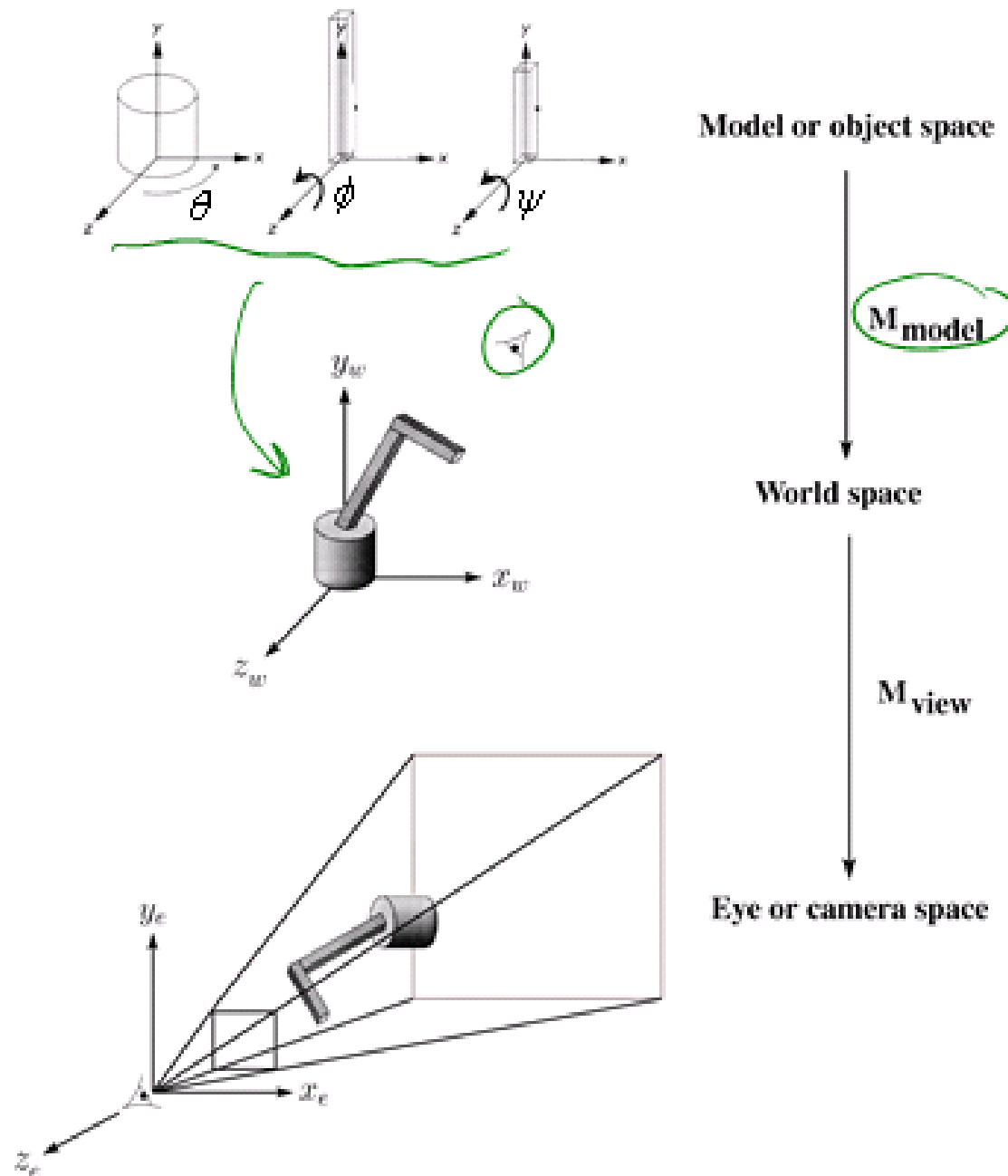

Robot arm implementation

The robot arm can be displayed by keeping a global matrix and computing it at each step:

```
Matrix M_model;
Matrix M_view;

main()
{
    . . .
    M_view = compute_view_transform();
    robot_arm();
    . . .
}

robot_arm()
{
    M_model = M_view*R_y(theta);
    base();
    M_model = M_view*R_y(theta)*T(0,h1,0)*R_z(phi);
    upper_arm();
    M_model = M_view*R_y(theta)*T(0,h1,0)
                *R_z(phi)*T(0,h2,0)*R_z(psi);
    lower_arm();
}
```

Do the matrix computations seem wasteful?

Yes!

Robot arm implementation, better

Instead of recalculating the global matrix each time, we can just update it *in place* by concatenating matrices on the right:

```
Matrix M_modelview;

main()
{
    . . .
    M_modelview = compute_view_transform();
    robot_arm();
    . . .
}

robot_arm()
{
    M_modelview *= R_y(theta);
    base();
    M_modelview *= T(0,h1,0)*R_z(phi);
    upper_arm();
    M_modelview *= T(0,h2,0)*R_z(psi);
    lower_arm();
}
```

Robot arm implementation, OpenGL

OpenGL maintains a global state matrix called the **model-view matrix**, which is updated by concatenating matrices on the *right*.

```
main()
{
    . . .
    glMatrixMode( GL_MODELVIEW );
    Matrix M = compute_view_xform();
    glLoadMatrixf( M );
    robot_arm();
    . . .
}

robot_arm()
{
    glRotatef( theta, 0.0, 1.0, 0.0 );
    base();
    glTranslatef( 0.0, h1, 0.0 );
    glRotatef( phi, 0.0, 0.0, 1.0 );
    lower_arm();
    glTranslatef( 0.0, h2, 0.0 );
    glRotatef( psi, 0.0, 0.0, 1.0 );
    upper_arm();
}
```

Hierarchical modeling

Hierarchical models can be composed of instances using trees or DAGs:

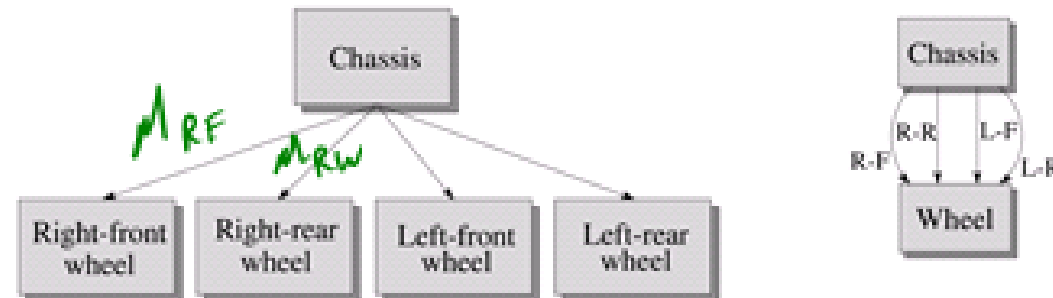

- ◆ edges contain geometric transformations
- ◆ nodes contain geometry (and possibly drawing attributes)

How might we draw the tree for the robot arm?

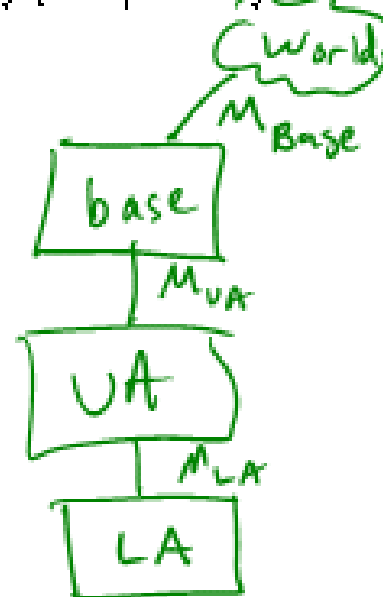

A complex example: human figure

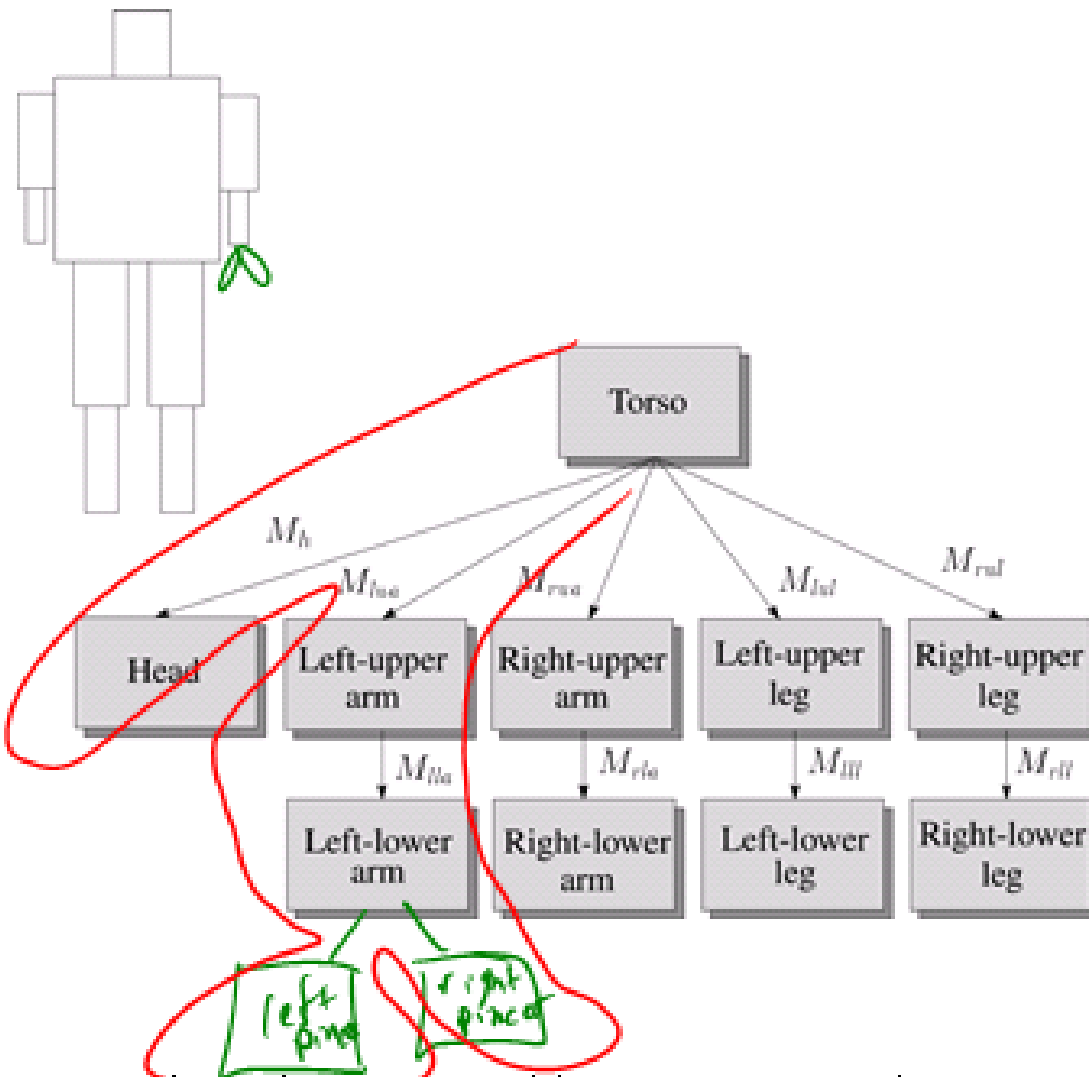

Q: What's the most sensible way to traverse this tree?

Depth view traversal

Human figure implementation, OpenGL

```
figure()
{
    torso();
    glPushMatrix();
        glTranslate( ... );
        glRotate( ... );
        head();
    glPopMatrix();
    glPushMatrix();
        glTranslate( ... );
        glRotate( ... );
        left_upper_arm();
        glPushMatrix();
            glTranslate( ... );
            glRotate( ... );
            left_lower_arm();
        glPopMatrix();
    glPopMatrix();
    ...
}
```

Animation

The above examples are called **articulated models**:

- ◆ rigid parts
- ◆ connected by joints

They can be animated by specifying the joint angles (or other display parameters) as functions of time.

Key-frame animation

The most common method for character animation in production is **key-frame animation**.

- ◆ Each joint specified at various **key frames** (not necessarily the same as other joints)
- ◆ System does interpolation or **in-betweening**

Doing this well requires:

- ◆ A way of smoothly interpolating key frames: **splines**
- ◆ A good interactive system
- ◆ A lot of skill on the part of the animator

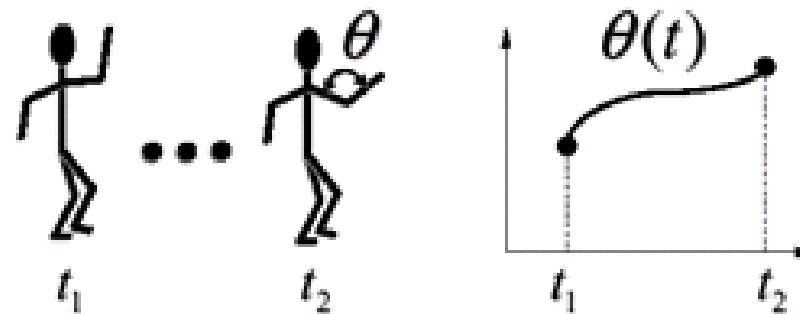

Scene graphs

The idea of hierarchical modeling can be extended to an entire scene, encompassing:

- ◆ many different objects
- ◆ lights
- ◆ camera position

This is called a **scene tree** or **scene graph**.

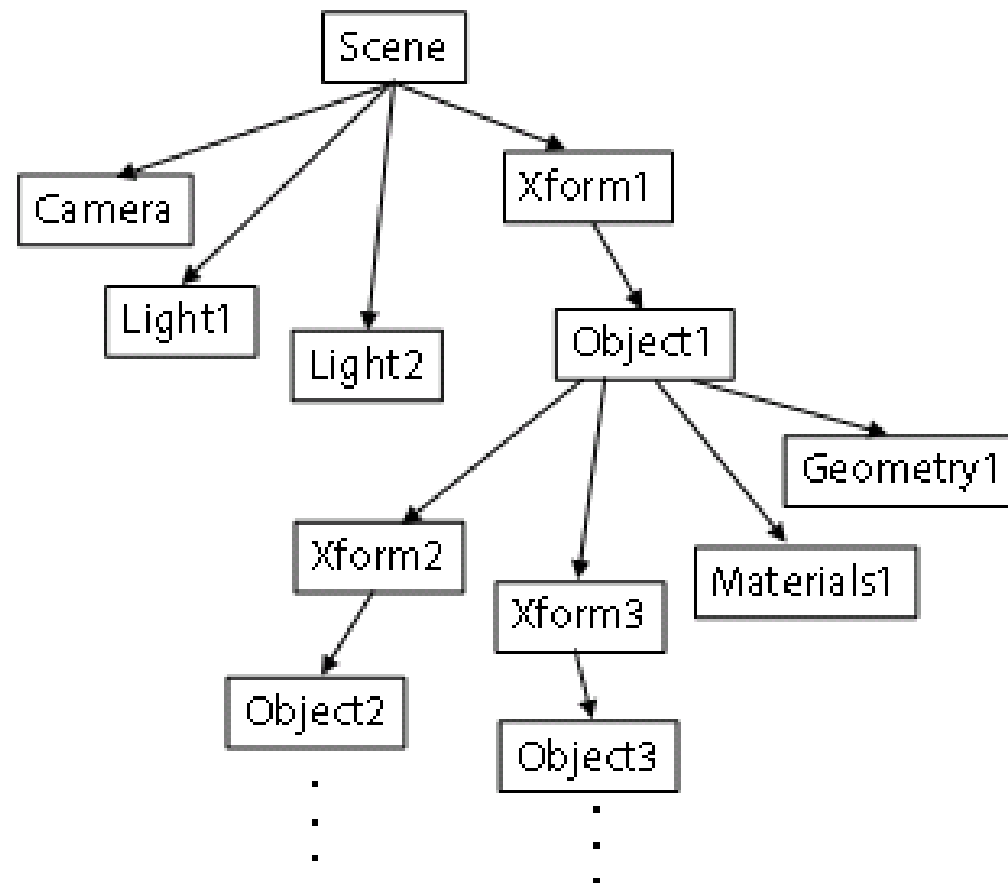

Summary

Here's what you should take home from this lecture:

- ◆ All the **boldfaced terms**.
- ◆ How primitives can be instanced and composed to create hierarchical models using geometric transforms.
- ◆ How the notion of a model tree or DAG can be extended to entire scenes.
- ◆ How OpenGL transformations can be used in hierarchical modeling.
- ◆ How keyframe animation works.