

CSE 461: Computer Networks

Kurtis Heimerl – kheimerl@cs

Matt Johnson – matt9j@cs

Zetian Chen – zetiach@cs

Chenyang Fang – chenyf@cs

Josh Curtis – curtjd@cs

Who we are





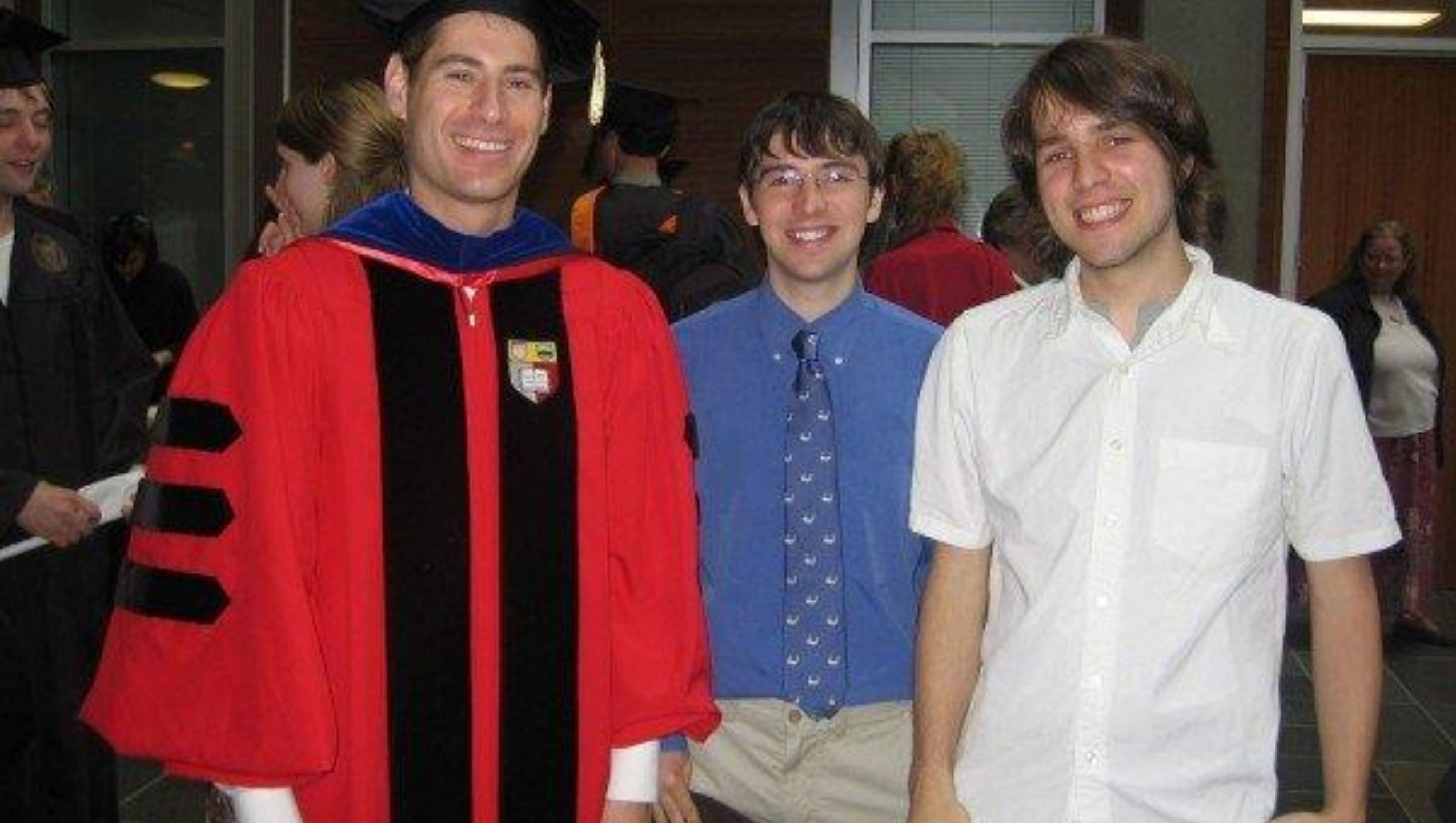





K KIL
Workin

+918.185

ICTD

ICTD

- Information and Communication Technology for Development
 - Development -> Poverty Alleviation (not software development)
 - Broad field covering health, justice, and **access**
- Why?
 - Lots of natural intuition from Alaska, I know rural.
 - Able to use networking skill -> Many opportunities (NSRC)
- My subfield: Cellular access
- My Answer: Community Cellular









BE THE PHONE COMPANY.

No more waiting for coverage: now you can build cellular networks yourself.

[Learn More](#)





Photo

Status

facebook

TAs Now!

Matt J.



- From Houston, TX, USA
- Grad Student at UW CSE
 - researching rural networking
- Love reading, photography, and bikes
- Office hours *Mondays* before class
M(11:30-12:30) in CSE2-131





I don't really have many photos 😞

Name: Chenyang Fang (Michael)

Year: Senior

What I like: Music Music and Music

Favorite Band:
The Stone Roses

Favorite Guitarist:
John Squire

Favorite Professor:
Kurtis Heimerl

Favorite Town:
KurtisTown



★ Designed by TownMapsUSA.com



➤ I'm a senior CSE undergrad

➤ I also minor in Japanese

➤ I love watching movies

➤ This is my first time TA-ing



Class Structure

Book

- Previous years used *Computer Networks (5E 12), Peterson*
 - Normal book for normal classes.
- We're moving to *Computer Networks (6E 19), Peterson*
 - Open source book still in development by same authors
 - Lots of repeated content
 - ++ -> It's free and covers new exciting things
 - -- -> It's buggy and there are no questions



Grading

- **Reading and Quizzes: 15%**
 - Reading from online book and quizzes per chapter held in section
 - Covers reading and in-class material
 - Expect around 6-7 of these



[This Photo](#) by Unknown author is licensed under [CC BY-SA](#).

Grading

- Reading and Quizzes: 15%
- **3 Projects: (15 + 15 + 15)%**
 - Socket programming (basic networking)
 - Link and Network layer behavior (link layer)
 - HTTP Proxy (application layer)



[This Photo](#) by Unknown author is licensed under [CC BY-NC-ND](#).

Grading

- Reading and Quizzes: 15%
- 3 Projects: (15 + 15 + 15)%
- **Midterm: 15%**
 - Somewhere in the middle of the quarter (was late October last year)

Grading

- Reading and Quizzes: 15%
- 3 Projects: (15 + 15 + 15)%
- Midterm: 15%
- **Final: 25%**
 - Comprehensive of all content from the class

Grading

- Reading and Quizzes: 15%
- 3 Projects: (15 + 15 + 15)%
- Midterm: 15%
- Final: 25%

Late Policy: Each **person** gets three late days. Late days will be decided at end of quarter and selected as to have the most positive impact.

Administrivia

- Office hours
 - Opportunity to have more personal interactions with both me and the TAs.
- Tools
 - Mailing list: primary class communications
 - Canvas Assignments: Homework and projects
 - Canvas Discussion: Back and forth discussions on class content
 - Canvas Gradebook: Grades will be posted here
- Slides
 - Adapted from David Wetherall, his talks are online
 - I will be posting my own slides right before lecture as well

Laptop Policy

- Laptops are fine
 - If you are going to be on Facebook do it in the back of class
 - This is distracting to other students
 - TAs will be enforcing this policy

Questions?

CSE 461: Computer Networks

Focus of the course

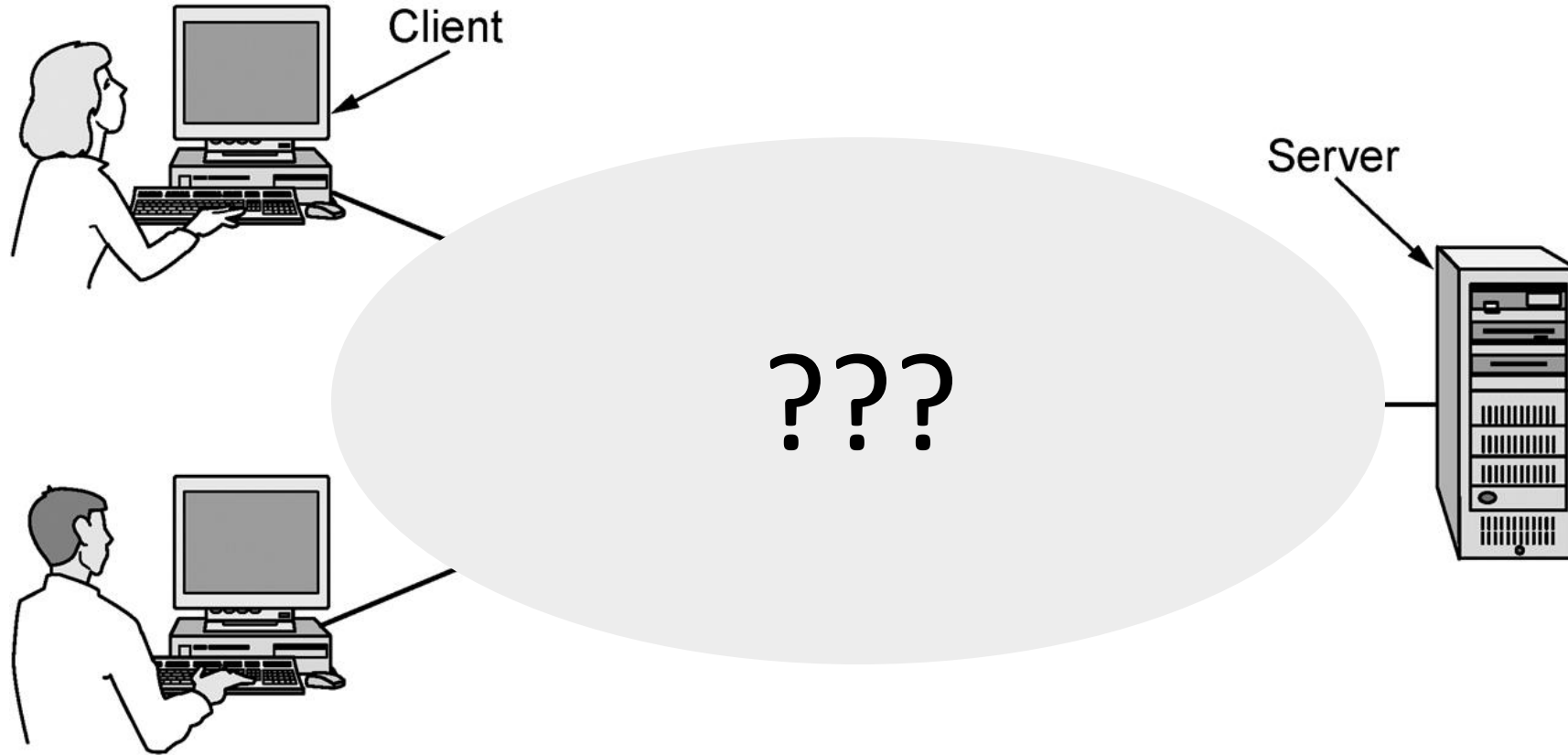

Focus of the course (in today's terms)

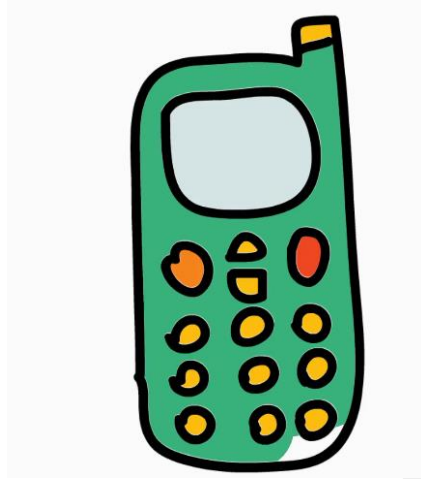

Client



???



Focus of the course (2)

- Three “networking” topics:

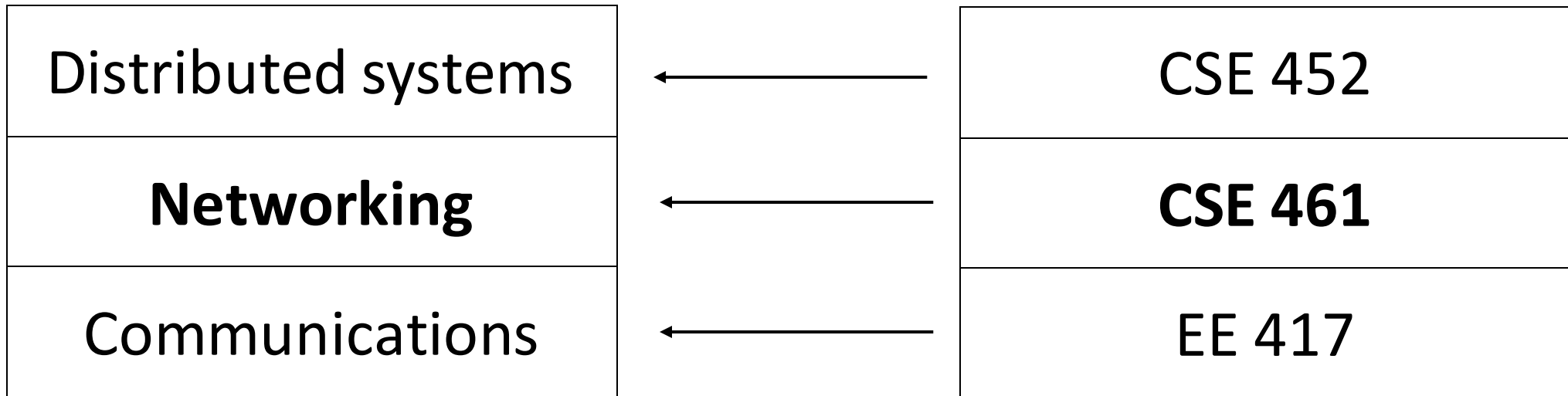

The Main Point

- 1. To learn the fundamentals of computer networks**
2. Learn how the Internet works
 - What really happens when you “browse the web”?
 - TCP/IP, DNS, HTTP, NAT, VPNs, 802.11 etc.
3. Understand why the internet is designed how it is designed
 - SDN, Load Balancers, Architectures

Why learn the Fundamentals?

1. Apply to all computer networks
2. Intellectual interest
3. Change / reinvention

Fundamentals – Intellectual Interest

- Example key problem: Reliability!
 - Any part of the Internet might fail
 - Messages might be corrupted
 - So how do we provide reliability?
- Reliability solutions
 - Codes to detect/correct errors
 - Routing around failures ...

Fundamentals – Intellectual Interest (2)

Key problem	Example solutions
Reliability despite failures	Codes for error detection/correction (§3.2, 3.3) Routing around failures (§5.2)
Network growth and evolution	Addressing (§5.6) and naming (§7.1) Protocol layering (§1.3)
Allocation of resources like bandwidth	Multiple access (§4.2) Congestion control (§5.3, 6.3)
Security against various threats	Confidentiality of messages (§8.2, 8.6) Authentication of communicating parties (§8.7)

Fundamentals – Reinvention

- The Internet is constantly being re-invented!
 - Growth over time and technology trends drive upheavals in Internet design and usage
- Today's Internet is different from yesterday's
 - Lots of new exciting things (QUIC, SDN, etc)
 - And tomorrow's will be different again
 - But the fundamentals remain the same

Fundamentals – Reinvention (2)

- Many billions of Internet hosts and growing ...
 - 5B+ on Cell Networks
 - 3B+ on Internet

Internet Domain Survey Host Count

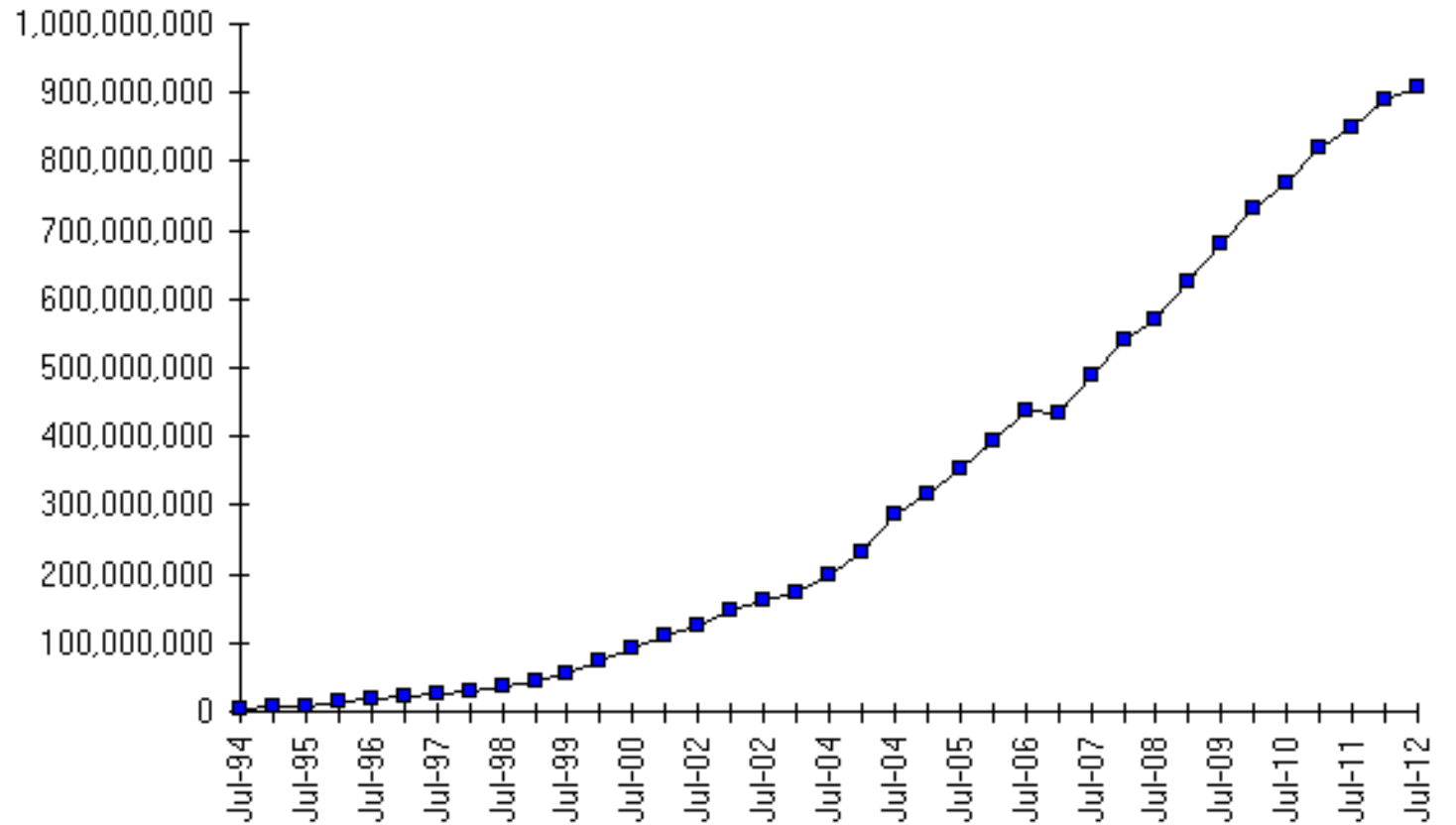

Source: Internet Systems Consortium (www.isc.org)

Fundamentals – Reinvention (3)

- Examples of upheavals in the past 1-2 decades

Change	Enabling Technology
Emergence of the web	Content Distribution Networks
Piracy	Peer-to-peer file sharing
Voice over IP (VoIP)	Quality of Service (QoS)*
Internet of Things	IPv6
Mobile Devices	Wireless Networking

*mostly actually spare capacity

Fundamentals – Reinvention (4)

- Upcoming/Ongoing upheavals?

Change	Enabling Technology
Fake News	Social Media
No-power devices?	Backscatter
Generic Networks?	SDN
Ubiquitous Networks?	Satellite/Long-Distance Networks
Videos as Comms	High-Bandwidth Mobile (4G/5G)

The Main Point

1. To learn the fundamentals of computer networks
- 2. Learn how the Internet works**
 - What really happens when you “browse the web”?
 - TCP/IP, DNS, HTTP, NAT, VPNs, 802.11 etc.
3. Understand why the internet is designed how it is designed
 - SDN, Load Balancers, Architectures

Who cares about the internet?

1. Curiosity
2. Impact on our world
3. Job prospects!

From this experimental network (~1970)...

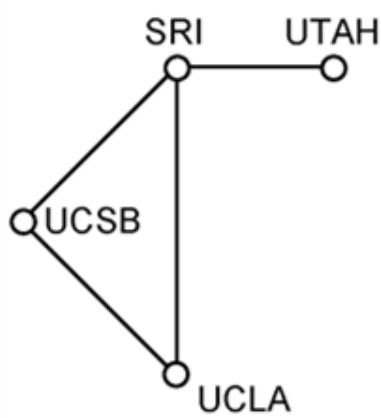

(a) Dec. 1969.

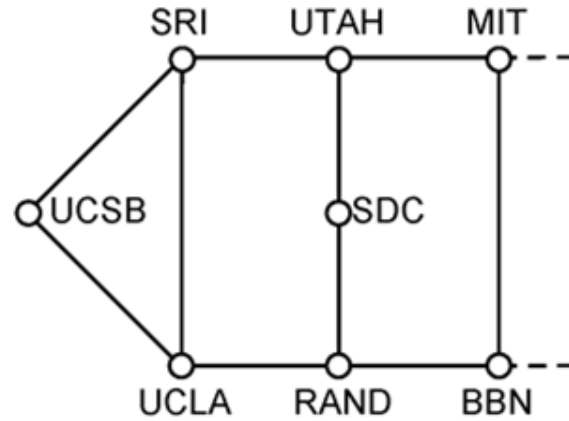

(b) July 1970.

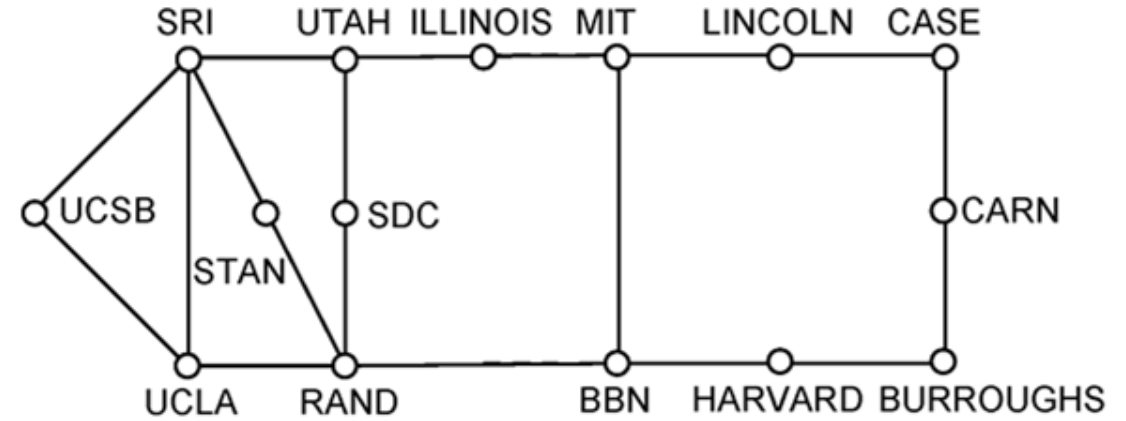

(c) March 1971.

ARPANET LOGICAL MAP, MARCH 1977

To this...

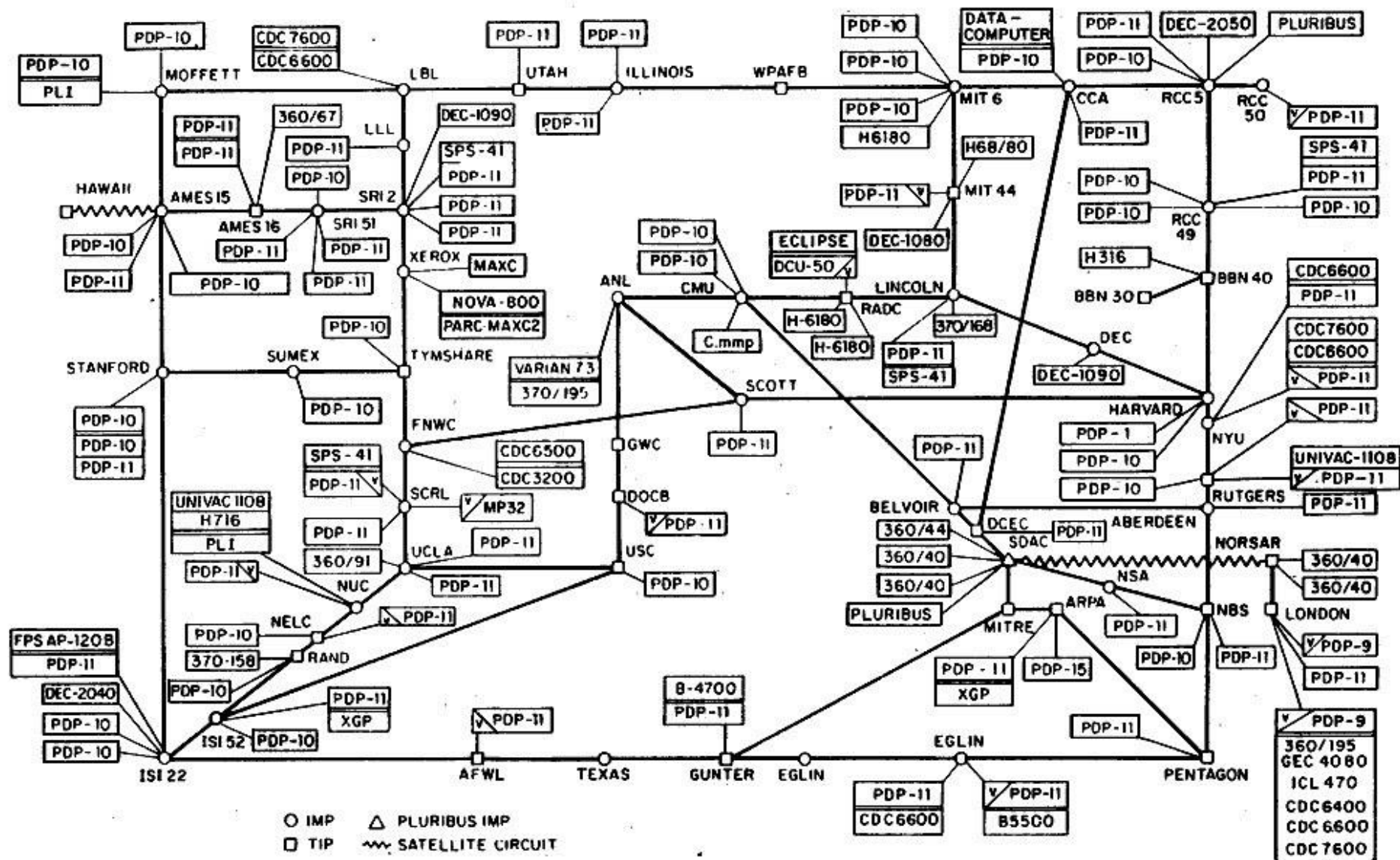

(PLEASE NOTE THAT WHILE THIS MAP SHOWS THE MOST POPULATION OF THE NETWORK ACCORDING TO THE BEST INFORMATION OBTAINABLE, NO CLAIM CAN BE MADE FOR ITS ACCURACY)

NAMES SHOWN ARE IMP NAMES, NOT (NECESSARILY) HOST NAMES

To this! (2011)

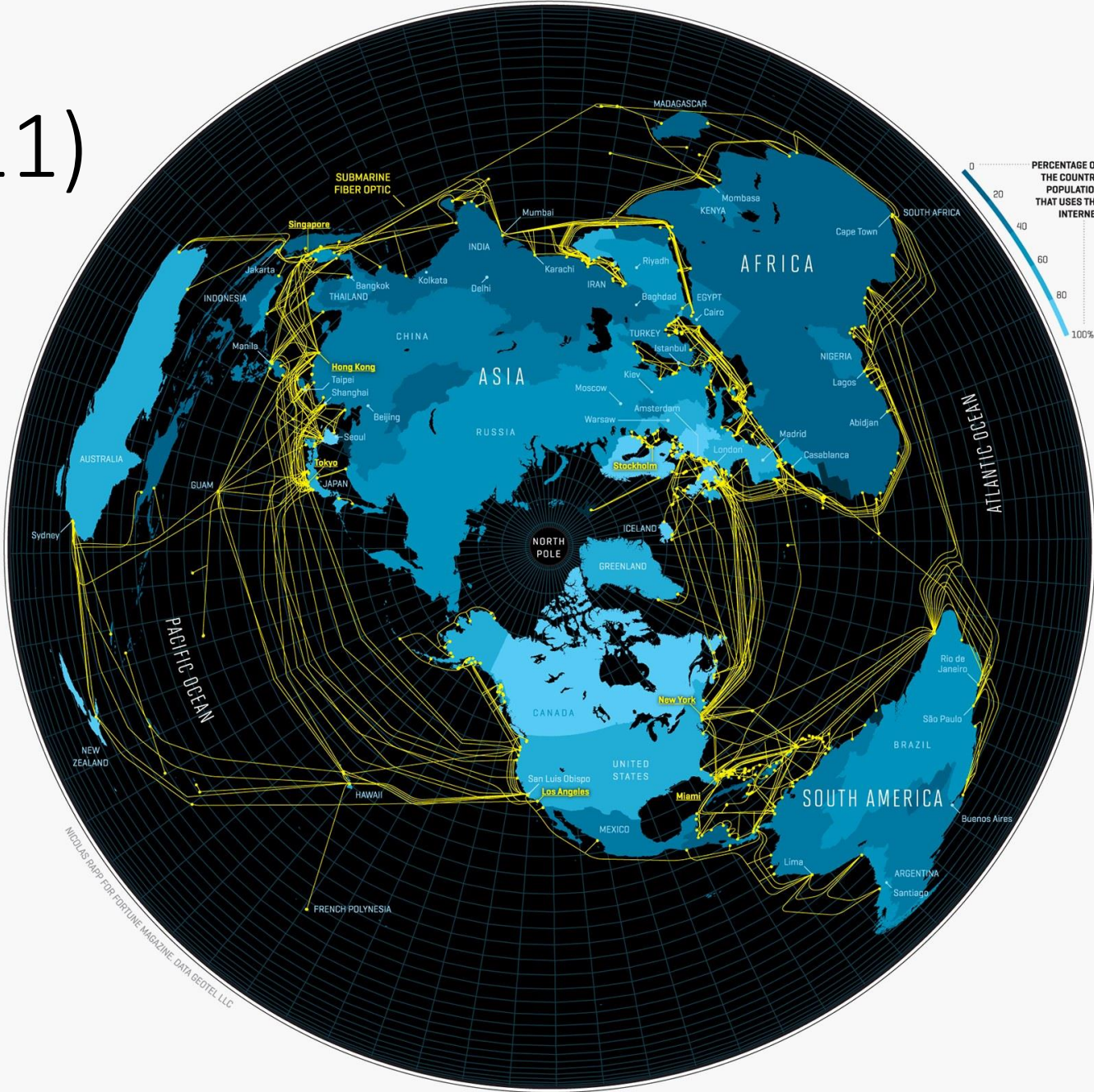

And this (2015)!

- An everyday institution used at work, home, and on-the-go
- Visualization contains millions of servers
 - Red = .com, Yellow= .org
- Network now contains literally 3 billion **people!**

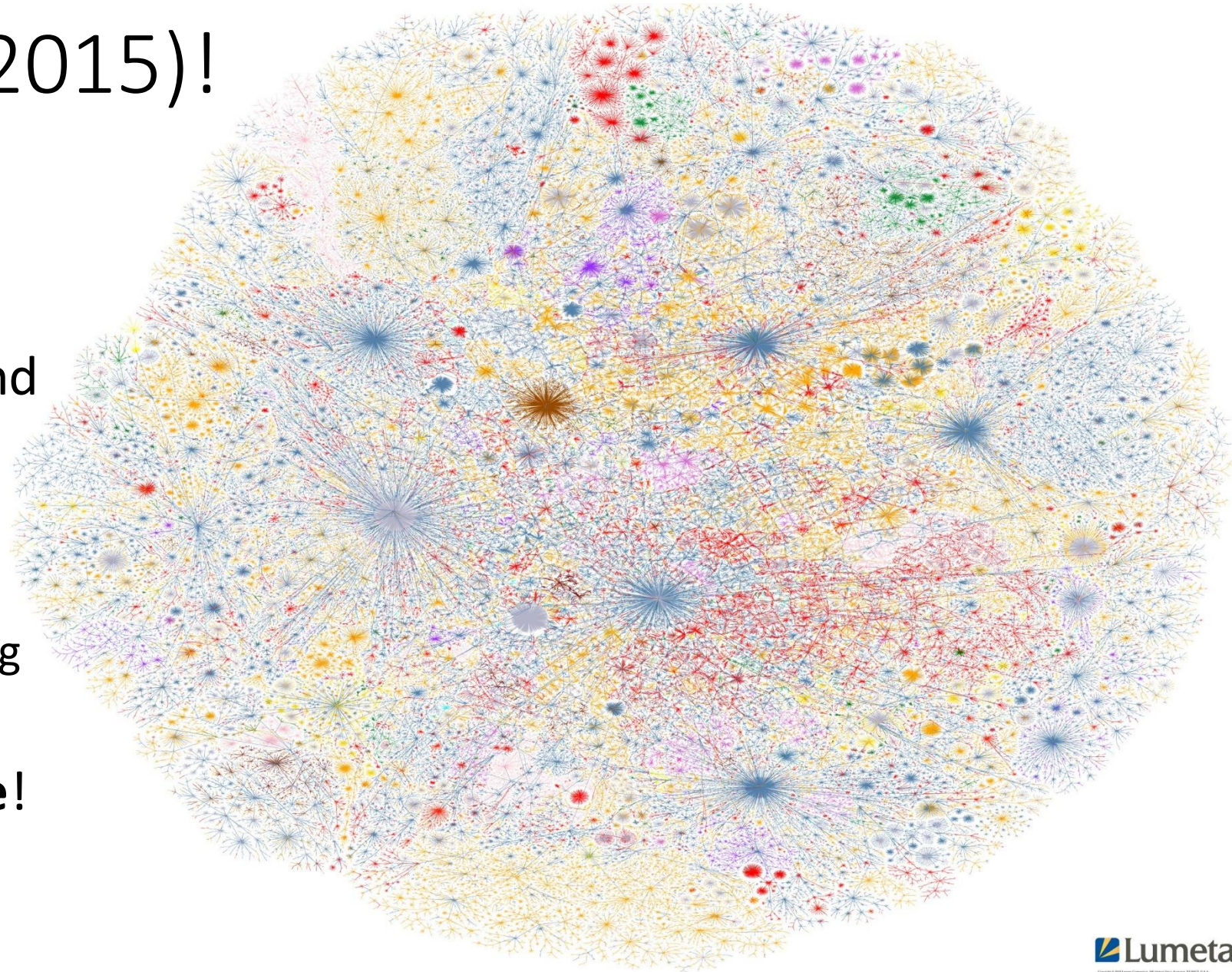

Internet – Societal Impact

- An enabler of societal change
 - ++ -> Easy access to knowledge
 - ++ -> Electronic commerce
 - ?? -> Personal relationships
 - ?? -> Private communications
 - -- -> Fake News
 - -- -> Arguing politics on Facebook



WIKIPEDIA



Internet – Economic impact

- An engine of economic growth
 - Information sources
 - And lots of ethical questions!
 - ++ -> Online marketplaces
 - ?? -> Social media/Crowdsourcing
 - -- -> "Gig economy"

The Google logo, featuring the word "Google" in its characteristic multi-colored font (blue, red, yellow, blue, green, red).The Facebook logo, consisting of the word "facebook" in white lowercase letters on a dark blue rectangular background.The eBay logo, featuring the word "eBay" in a stylized font with each letter in a different color (red, blue, yellow, green).The Craigslist logo, featuring the word "craigslist" in a purple, lowercase, sans-serif font.

The Main Point

1. To learn the fundamentals of computer networks
2. Learn how the Internet works
 - What really happens when you “browse the web”?
 - TCP/IP, DNS, HTTP, NAT, VPNs, 802.11 etc.
3. Understand why the internet is designed how it is designed
 - SDN, Load Balancers, Architectures

Architectures

- Lots of ways to build networks with different **tradeoffs**
- Goals:
 - Open Access (Internet)
 - Safety--, Security--, Flexibility++, Privacy++
 - Identity First (Cellular)
 - Safety++, Security++, Privacy --, Flexibility--
 - Centralized (Comcast)
 - Complexity++, Freedom--
 - Decentralized (Mesh)
 - Complexity--, Freedom++

Why things are how they are

- A bit of a reach – might not make it here
- Modern networking
 - Software defined networks (SDN)
 - Content Delivery Networks (CDN)
 - Cellular Networks
 - Domain Name Service (DNS)
 - Debugging tools: Dig/traceroute/whois

Not a Course Goal

To learn IT job skills

- How to configure specific equipment or technologies
 - e.g., Cisco certifications,
 - Technical whack-a-mole
- But course material is relevant, and we use hands-on tools
 - Hopefully you'll be able to use these tools to build stuff at the end of class