

CSE 461: Computer Networks

Spring 2022

Ratul Mahajan

Jason Wyatt Miller, Monty Nitschket,

Edan Tessel Sneh, Mark Theeranantachai

Who we are

Ratul

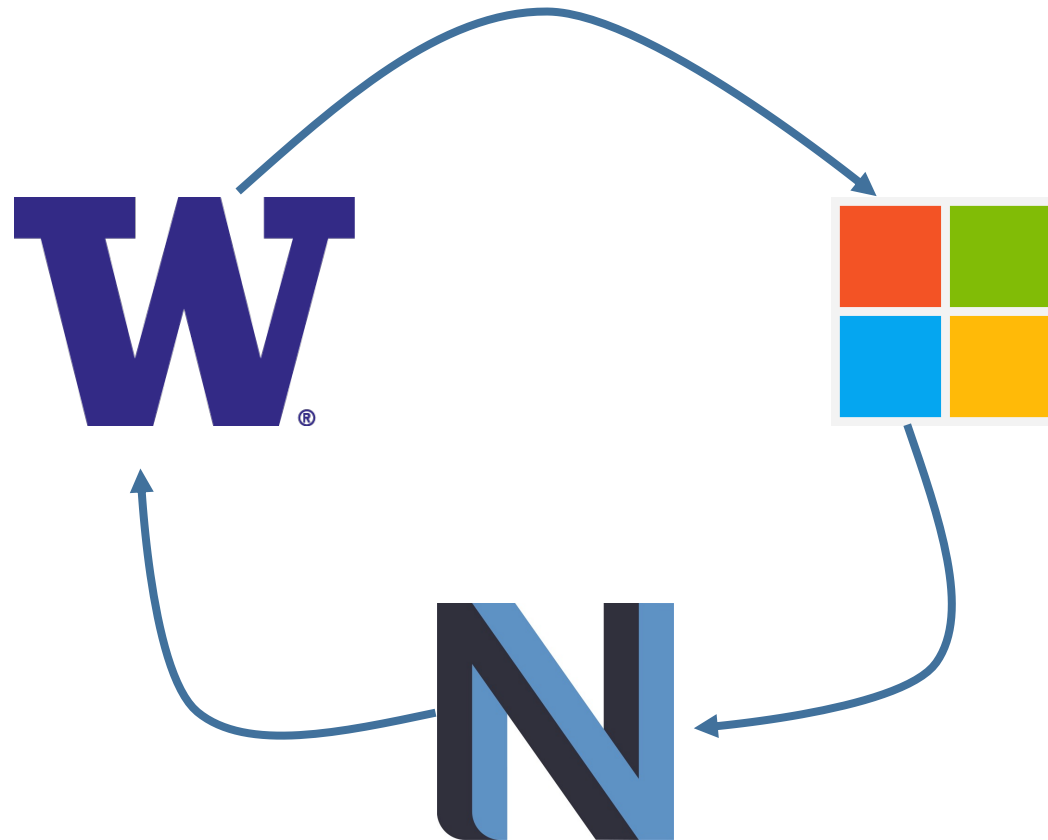

Jason Miller

- Hometown: Mukilteo, Washington
- Year: Junior, graduating June 2023
- Some fun facts:
 - Double major in CS and math, minor in applied math
 - I like rock climbing
 - I went to Vancouver over Spring break
 - I have a cat named Cosmo:

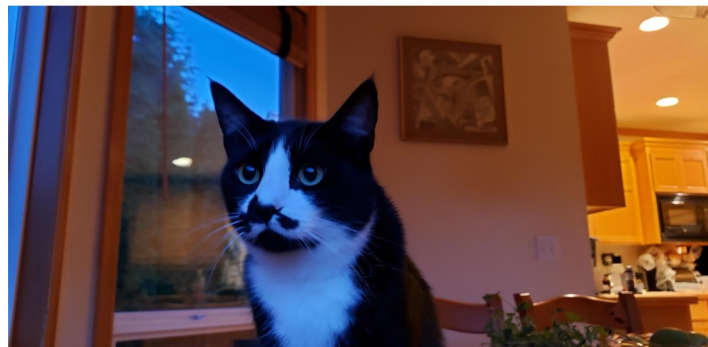

Monty Nitschke

Hometown: Spokane, Washington

Year: BS/MS, graduating Autumn 2022!

Some fun facts about me:

- Transfer student from CC
- Fourth time TA :)
 - Previous TA for 332, 351
- Love to go hiking and camping
- Love board games and card games



Edan Sneh

Hometown: Palo Alto, California

Year: BS/MS, graduating Spring 2022!

Some fun facts about me:

Love rock climbing

Love all sorts of puzzles and strategy games

I enjoy eating food and cooking meals

Absolutely hate flying but love traveling



Mark Theeranantachai

- Hometown: Thailand
- Year: Undergraduate Senior
- Graduating June 2022
- Some fun facts:
 - Really love live music and jamming (usually rock/pop)
 - Can play a lot of instruments but not so good at any :
 - Sony Fanboy, have used 5 Xperia phones
 - Love thriller and action films/TV shows
 - Enjoy snowboarding, tennis, photography, and cycling
 - Thai foods are too spicy :(
 - Casual Dota2 player (900 hrs)
 - Currently work at the ICTD lab and pursuing a PhD.



CSE 461: Computer Networks

Focus of the course

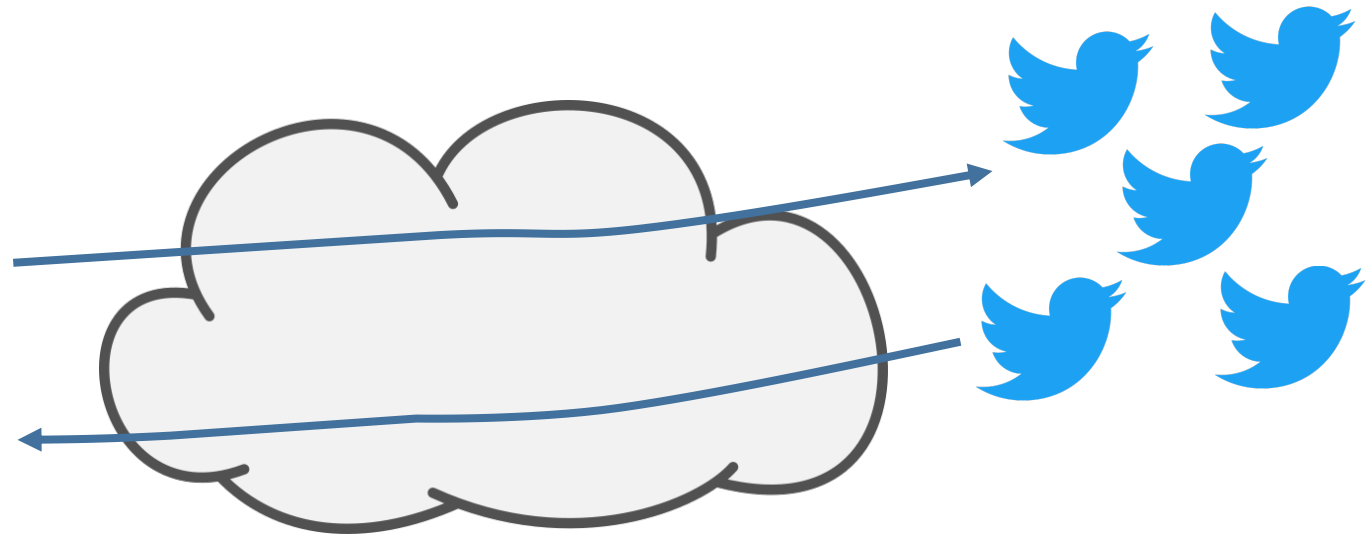
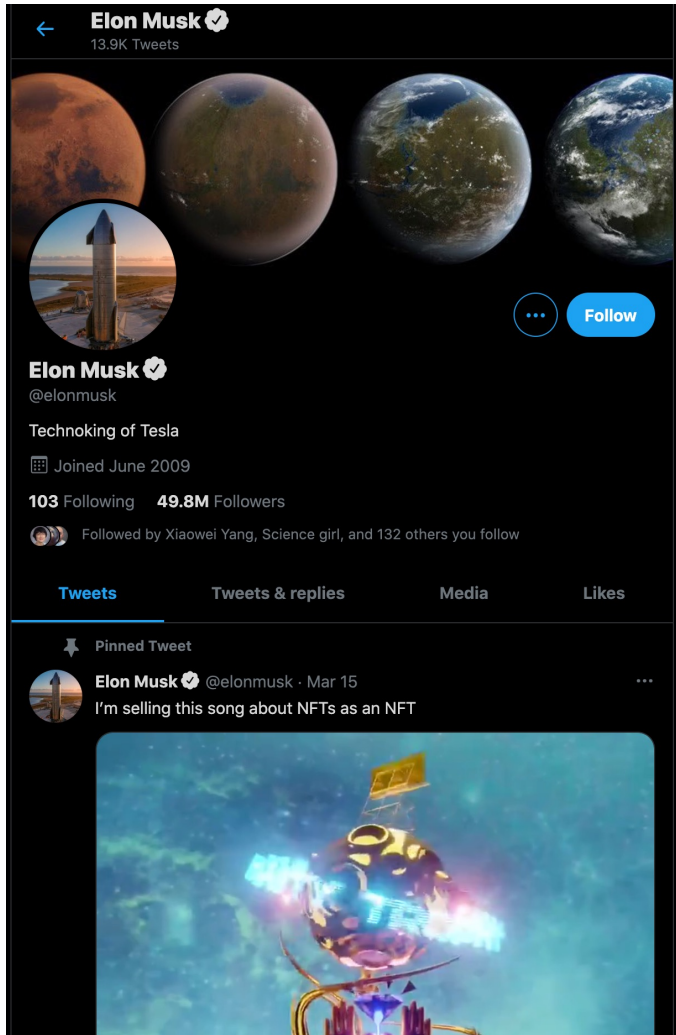

Focus of the course (2)

Three “networking” topics:

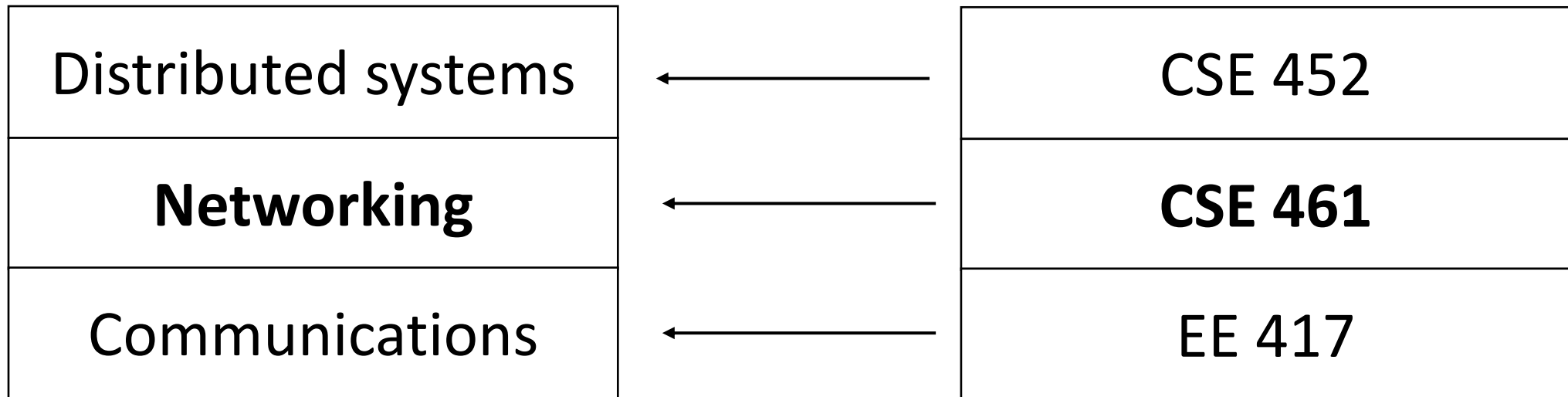

Main goals

1. Learn the fundamentals of computer networks
- 2. Learn how the Internet works**
 - What really happens when you “browse the web”?
 - TCP/IP, DNS, HTTP, NAT, VPNs, 802.11 etc.
3. Understand how and why of Internet design
 - SDN, Load Balancers, Architectures

Why learn the fundamentals?

Intellectual interest

Reinvention, broad applicability

- Non-Internet networks
- Changing Internet

Fundamentals - Reliable communication

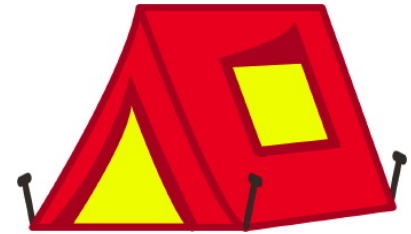
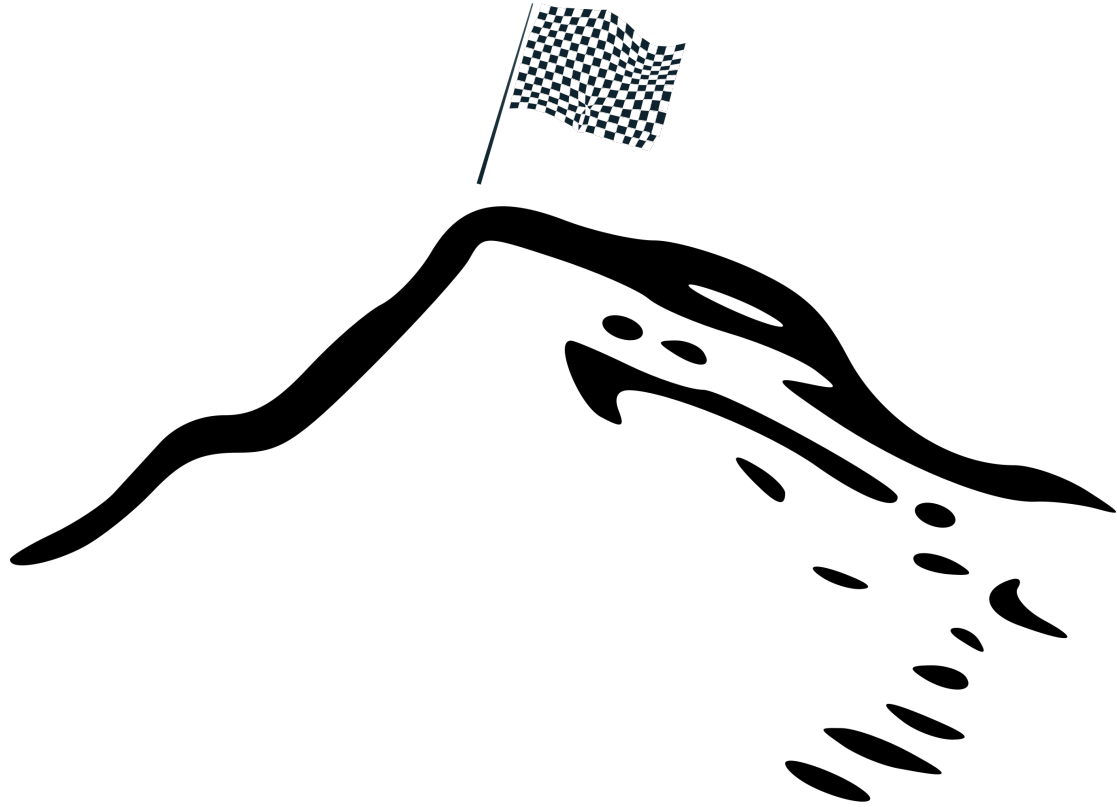
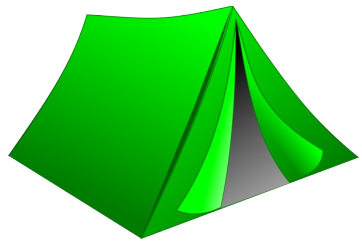

Fundamentals – Channel throughput



1 Gbps

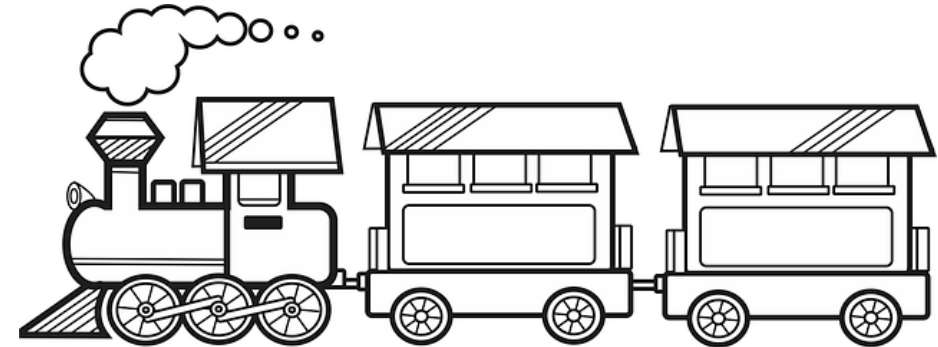

20ft container = 2,350,080 in³ (240 x 96 x 102)
3.5in SSD = 23 in³ (4 x 5.75 x 1)
SSDs / container = 50K (50% packing efficiency)
Container capacity = 25PB (512 GB per SSD)
Container speed = 100 mph
SEA <> NYC throughput = ~2000 Gbps

Fundamentals – Reinvention

- The Internet is constantly being re-invented!
 - Growth over time and technology trends drive upheavals in Internet design
- Today's Internet is different from yesterday's
 - And tomorrow's will be different again
 - But the fundamentals remain the same

Internet growth

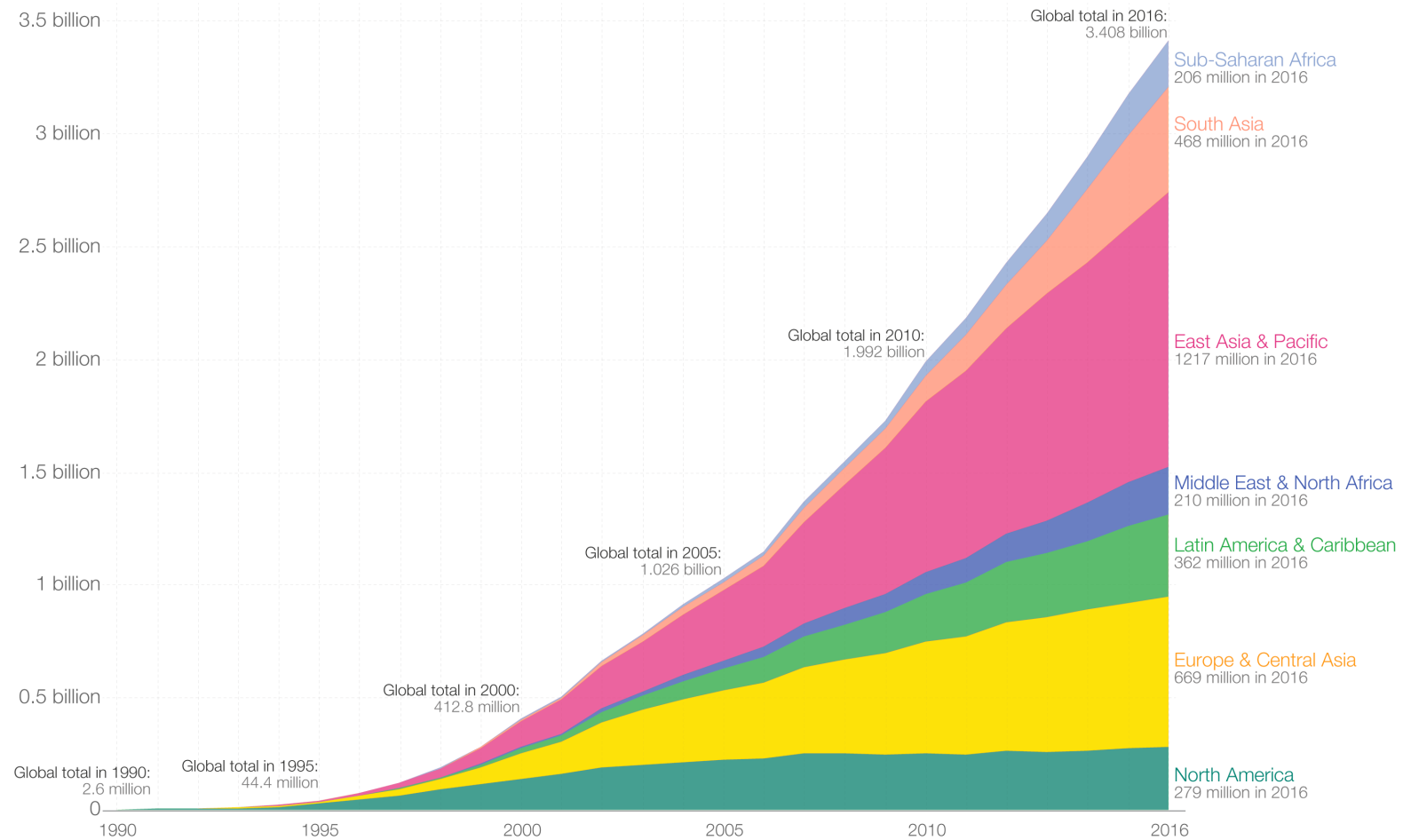

Data source: Based on data from the World Bank and data from the International Telecommunications Union. Internet users are people with access to the worldwide network. The interactive data visualization is available at [OurWorldinData.org](https://ourworldindata.org). There you find the raw data and more visualizations on this topic. Licensed under [CC-BY-SA](https://creativecommons.org/licenses/by-sa/4.0/) by the author Max Roser.

Example upheavals

Change	Enabling Technology
Emergence of Web	Content Distribution Networks
Piracy	Peer-to-peer file sharing
Internet of Things	IPv6
Mobile Devices	Wireless, High bandwidth cellular
Cloud computing	Virtualization
Crypto currencies	Blockchains
....

Main goals

1. To learn the fundamentals of computer networks
2. Learn how the Internet works
 - What really happens when you “browse the web”?
 - TCP/IP, DNS, HTTP, NAT, VPNs, 802.11 etc.
3. Understand how and why of Internet design
 - SDN, Load Balancers, Architectures

Who cares about the internet?

1. Curiosity
2. Impact on our world
3. Job prospects!

From this experimental network (~1970)...

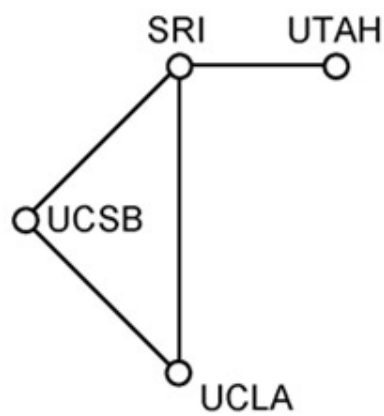

(a) Dec. 1969.

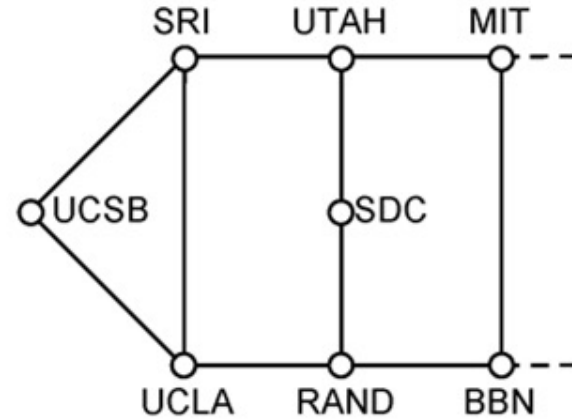

(b) July 1970.

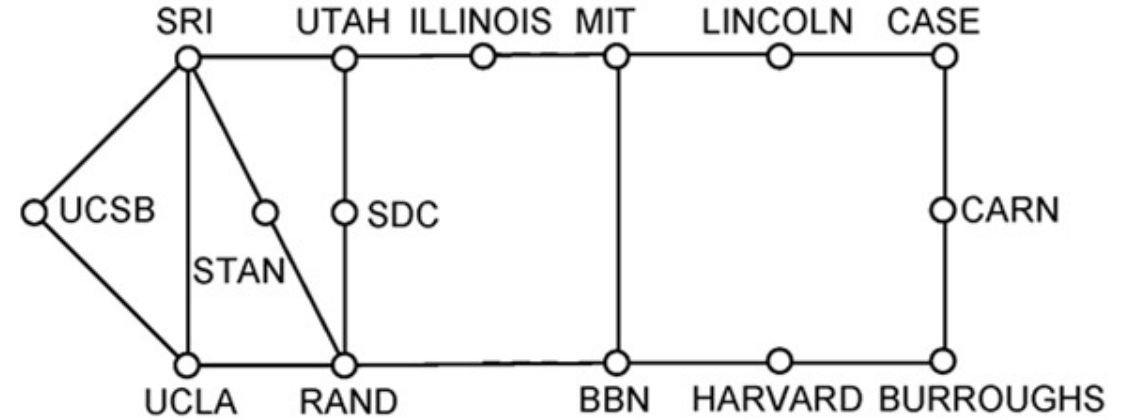

(c) March 1971.

ARPANET LOGICAL MAP, MARCH 1977

To this...

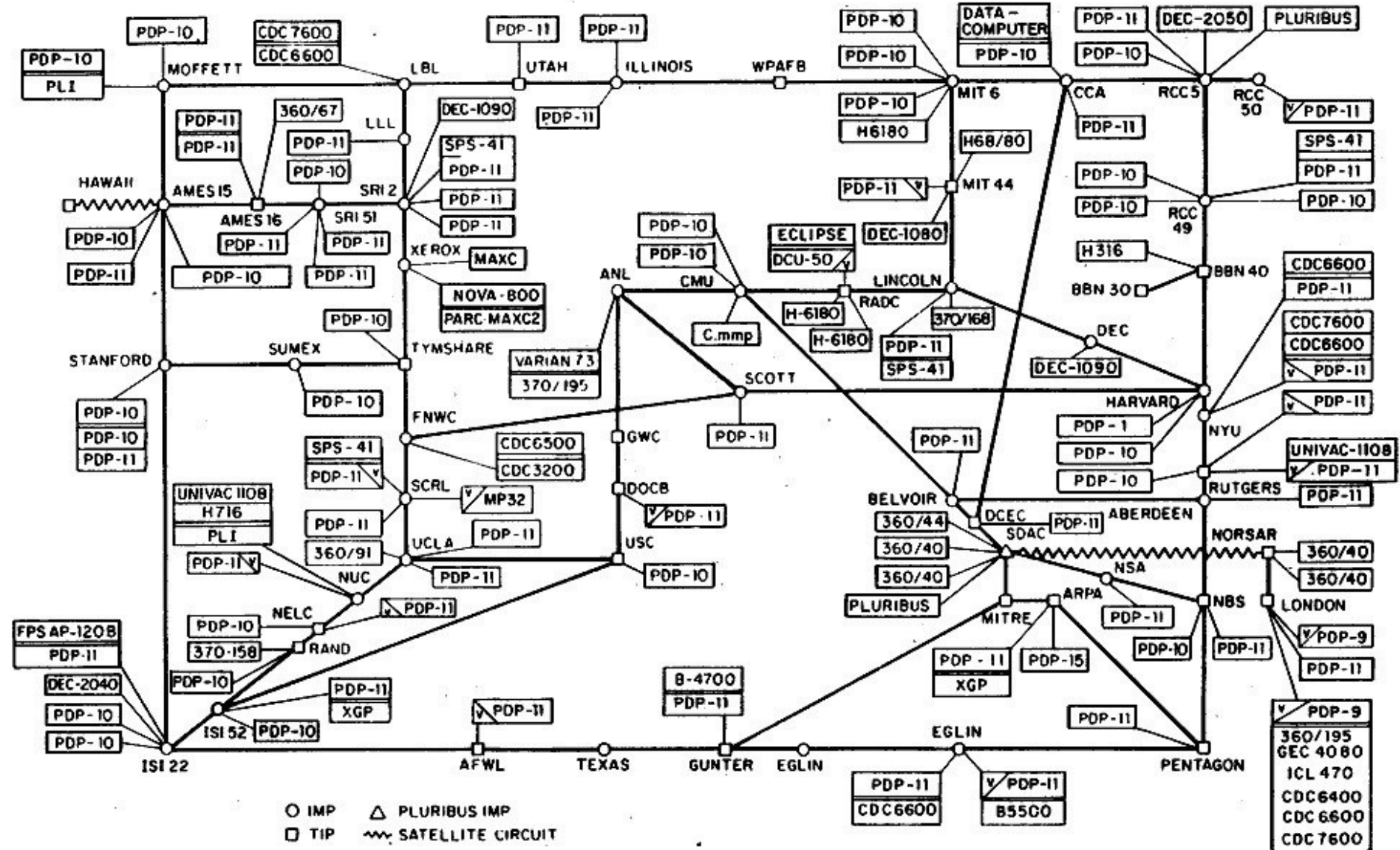

(PLEASE NOTE THAT WHILE THIS MAP SHOWS THE HOST POPULATION OF THE NETWORK ACCORDING TO THE BEST INFORMATION OBTAINABLE, NO CLAIM CAN BE MADE FOR ITS ACCURACY)

NAMES SHOWN ARE IMP NAMES, NOT (NECESSARILY) HOST NAMES

To this! (2011)

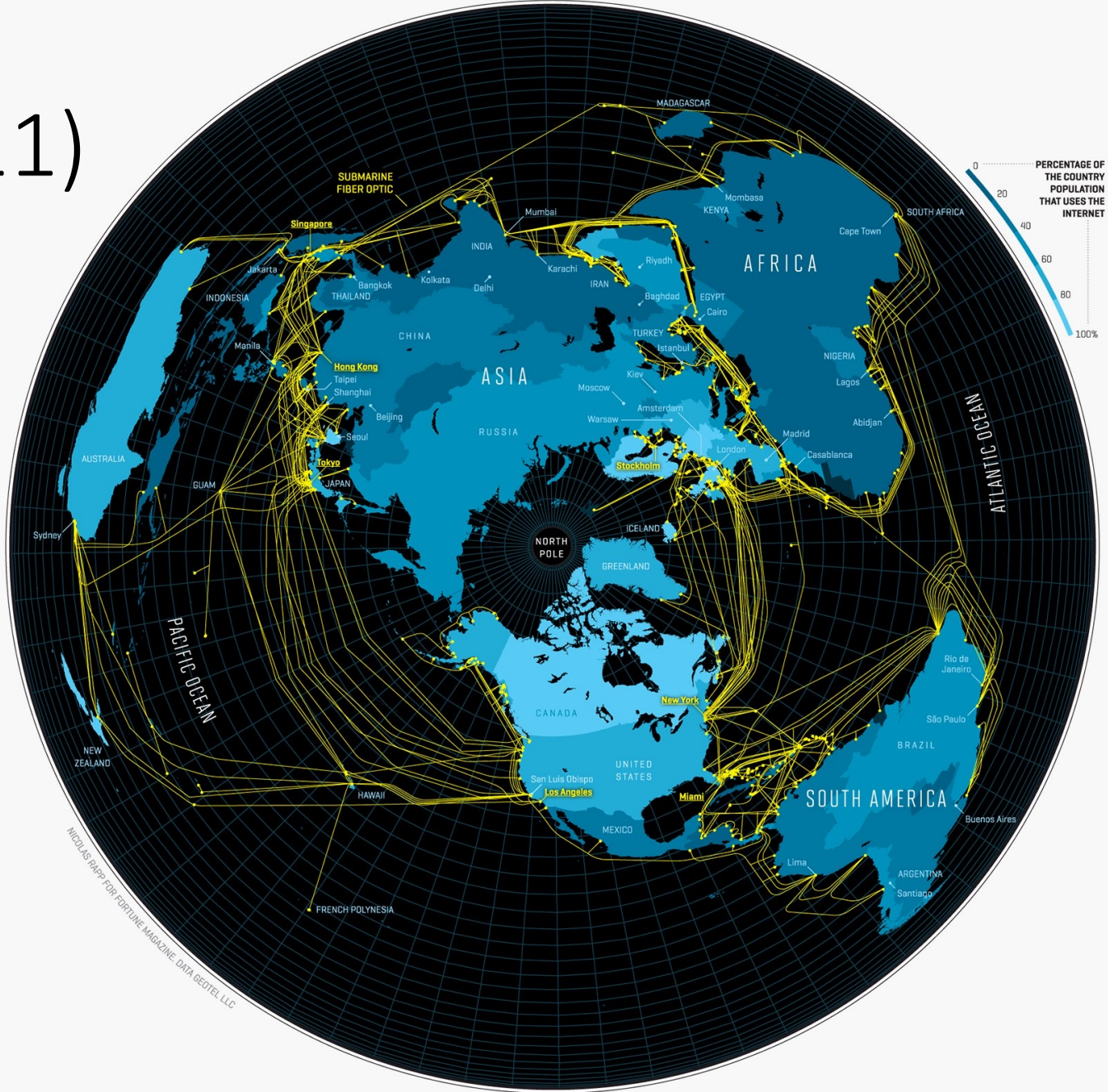

Internet – Societal Impact

- An enabler of societal change
 - Easy access to knowledge
 - Electronic commerce
 - Personal relationships
 - Private communications



WIKIPEDIA



Internet – Economic impact

- An engine of economic growth
 - Information sources
 - And lots of ethical questions!
 - Online marketplaces
 - Social media/Crowdsourcing

The Google logo, featuring the word "Google" in its characteristic multi-colored font (blue, red, yellow, blue, green, red).The Facebook logo, consisting of the word "facebook" in white lowercase letters on a dark blue rectangular background.The eBay logo, featuring the word "eBay" in a stylized font with each letter in a different color (red, blue, yellow, green).The Craigslist logo, featuring the word "craigslist" in a purple, lowercase, serif font.

Main goals

1. To learn the fundamentals of computer networks
2. Learn how the Internet works
 - What really happens when you “browse the web”?
 - TCP/IP, DNS, HTTP, NAT, VPNs, 802.11 etc.
3. Understand how and why of Internet design
 - SDN, Load Balancers, Architectures

Architectures

Lots of ways to build networks with different **tradeoffs**

- Internet -- open access
 - Flexibility++, Privacy++, Security--
- Cellular -- identity first
 - Flexibility--, Privacy --, Security++,



Not a Course Goal

To learn IT job skills

- How to configure specific equipment or technologies
 - e.g., Cisco certifications,
 - Technical whack-a-mole
- But course material is relevant, and we use hands-on tools
 - Hopefully you'll be able to use these tools to build stuff at the end of class

Main goals

1. To learn the fundamentals of computer networks
2. Learn how the Internet works
 - What really happens when you “browse the web”?
 - TCP/IP, DNS, HTTP, NAT, VPNs, 802.11 etc.
3. Understand how and why of Internet design
 - SDN, Load Balancers, Architectures

Questions?

Class Structure

Grading

Assignments: 10%

- Reading and homework from the book

Grading

Assignments: 10%

In-class Quizzes: 5%

- Short quizzes during the quarter
- Drop lowest

Grading

Assignments: 10%

In-class Quizzes: 10%

3 Projects: (15 + 15 + 15)%

- 3 coding exercises:
 - Socket programming
 - Link and Network layer behavior
 - Buffer bloat

Grading

Assignments: 10%

In-class Quizzes: 5%

3 Projects: (15 + 15 + 15)%

Midterm: 15%

Final: 20%

Participation: 5%

Grading

Assignments: 10%

In-class Quizzes: 5%

3 Projects: (15 + 15 + 15)%

Midterm: 15%

Final: 20%

Participation: 5%

Late Policy:

- 10% penalty for each late day
- Each **person** gets three late days

Administrivia

- Office hours
 - Opportunity to have more personal interactions with course staff.
- Tools
 - Canvas: Assignments, quizzes, and projects
 - ed discussion: Back and forth discussions on class content, announcements
 - Canvas Gradebook: Grades will be posted here
- Slides
 - Adapted from Kurtis Heimerl, who adapted from David Wetherall
 - I will be posting my own slides online

Questions?