

Software Security: Buffer Overflow Attacks and Beyond

Tadayoshi Kohno

Slides derived from Vitaly Shmatikov's

Goals for Today

- ◆ Software security
 - Buffer overflow attacks
 - Other software security issues
- ◆ Practice thinking about the security issues affecting real systems

Software problems are ubiquitous

Software Bug Halts F-22 Flight

Posted by kdawson on Sunday February 25, @06:35PM from the dare-you-to-cross-this-line dept.

mgh02114 writes

"The new US stealth fighter, the F-22 Raptor, was deployed for the first time to Asia earlier this month. On Feb. 11, twelve Raptors flying from Hawaii to Japan were forced to turn back when a software glitch crashed all of the F-22s' on-board computers as they crossed the international date line. The delay in arrival in Japan was previously reported, with rumors of problems with the software. CNN television, however, this morning reported that every fighter completely lost all navigation and communications when they crossed the international date line. They reportedly had to turn around and follow their tankers by visual contact back to Hawaii. According to the CNN story, if they had not been with their tankers, or the weather had been bad, this would have been serious. CNN has not put up anything on their website yet."



Software problems are ubiquitous

1985-1987 -- Therac-25 medical accelerator. A radiation therapy device malfunctions and delivers lethal radiation doses at several medical facilities. Based upon a previous design, the Therac-25 was an "improved" therapy system that could deliver two different kinds of radiation: either a low-power electron beam (beta particles) or X-rays. The Therac-25's X-rays were generated by smashing high-power electrons into a metal target positioned between the electron gun and the patient. A second "improvement" was the replacement of the older Therac-20's electromechanical safety interlocks with software control, a decision made because software was perceived to be more reliable.

What engineers didn't know was that both the 20 and the 25 were built upon an operating system that had been kludged together by a programmer with no formal training. Because of a subtle bug called a "race condition," a quick-fingered typist could accidentally configure the Therac-25 so the electron beam would fire in high-power mode but with the metal X-ray target out of position. At least five patients die; others are seriously injured.

<http://www.wired.com/software/coolapps/news/2005/11/69355>

Software problems are ubiquitous

January 15, 1990 -- AT&T Network Outage. A bug in a new release of the software that controls AT&T's #4ESS long distance switches causes these mammoth computers to crash when they receive a specific message from one of their neighboring machines -- a message that the neighbors send out when they recover from a crash.

One day a switch in New York crashes and reboots, causing its neighboring switches to crash, then their neighbors' neighbors, and so on. Soon, 114 switches are crashing and rebooting every six seconds, leaving an estimated 60 thousand people without long distance service for nine hours. The fix: engineers load the previous software release.

<http://www.wired.com/software/coolapps/news/2005/11/69355>

Software problems are ubiquitous

- ◆ NASA Mars Lander
 - Bug in translation between English and metric units
 - Cost taxpayers \$165 million
- ◆ Denver Airport baggage system
 - Bug caused baggage carts to become out of "sync," overloaded, etc.
 - Delayed opening for 11 months, at \$1 million per day
- ◆ Other fatal or potentially fatal bugs
 - US Vicennes tracking software
 - MV-22 Ospray
 - Medtronic Model 8870 Software Application Card

From *Exploiting Software* and <http://www.fda.gov/cdrh/recalls/recall-082404b-pressrelease.html>

Adversarial Failures

- ◆ Software bugs are bad
 - Consequences can be serious
- ◆ Even worse when an **intelligent adversary** wishes to **exploit** them!
 - Intelligent adversaries: Force bugs into “**worst possible**” conditions/states
 - Intelligent adversaries: Pick their targets
- ◆ **Buffer overflows bugs**: Big class of bugs
 - Normal conditions: Can sometimes cause systems to fail
 - Adversarial conditions: Attacker able to violate security of your system (control, obtain private information, ...)

A Bit of History: Morris Worm

- ◆ Worm was released in 1988 by Robert Morris
 - Graduate student at Cornell, son of NSA chief scientist
 - Convicted under Computer Fraud and Abuse Act, sentenced to 3 years of probation and 400 hours of community service
 - Now an EECS professor at MIT
- ◆ Worm was intended to propagate slowly and harmlessly measure the size of the Internet
- ◆ Due to a coding error, it created new copies as fast as it could and overloaded infected machines
- ◆ \$10-100M worth of damage

Morris Worm and Buffer Overflow

- ◆ We'll consider the Morris worm in more detail when talking about worms and viruses
- ◆ One of the worm's propagation techniques was a **buffer overflow attack** against a vulnerable version of fingerd on VAX systems
 - By sending special string to finger daemon, worm caused it to execute code creating a new worm copy
 - Unable to determine remote OS version, worm also attacked fingerd on Suns running BSD, causing them to crash (instead of spawning a new copy)

Buffer Overflow These Days

- ◆ Very common cause of Internet attacks
 - In 1998, over 50% of advisories published by CERT (computer security incident report team) were caused by buffer overflows
- ◆ Morris worm (1988): overflow in fingerd
 - 6,000 machines infected
- ◆ CodeRed (2001): overflow in MS-IIS server
 - 300,000 machines infected in 14 hours
- ◆ SQL Slammer (2003): overflow in MS-SQL server
 - 75,000 machines infected in **10 minutes (!)**

Attacks on Memory Buffers

- ◆ **Buffer** is a data storage area inside computer memory (stack or heap)
 - Intended to hold pre-defined amount of data
 - If more data is stuffed into it, it spills into adjacent memory
 - If executable code is supplied as “data”, victim's machine may be fooled into executing it – we'll see how
 - Code will self-propagate or give attacker control over machine
- ◆ First generation exploits: stack smashing
- ◆ Second gen: heaps, function pointers, off-by-one
- ◆ Third generation: format strings and heap management structures

Stack Buffers

- | | | |
|--|-----|--|
| | buf | |
|--|-----|--|
- ◆ Suppose Web server contains this function

```
void func(char *str) {
    char buf[126];
    ...
    strcpy(buf, str);
    ...
}
```
 - ◆ **No bounds checking on strcpy()**
 - ◆ If str is longer than 126 bytes
 - Program may crash
 - Attacker may change program behavior

Stack Buffers

buf

- ◆ Suppose Web server contains this function

```
void func(char *str) {  
    char buf[126];  
    ...  
    strcpy(buf, str);  
    ...  
}
```

- ◆ No bounds checking on strcpy()
- ◆ If str is longer than 126 bytes
 - Program may crash
 - Attacker may change program behavior

Stack Buffers

buf

uh oh!

- ◆ Suppose Web server contains this function

```
void func(char *str) {  
    char buf[126];  
    ...  
    strcpy(buf, str);  
    ...  
}
```

- ◆ No bounds checking on strcpy()
- ◆ If str is longer than 126 bytes
 - Program may crash
 - Attacker may change program behavior

Changing Flags

buf

authenticated

- ◆ Suppose Web server contains this function

```
void func(char *str) {  
    int authenticated = 0;  
    char buf[126];  
    ...  
    strcpy(buf, str);  
    ...  
}
```

- ◆ Authenticated variable non-zero when user has extra privileges
- ◆ Morris worm also overflowed a buffer to overwrite an authenticated flag in in.fingerd

Changing Flags

buf

authenticated

- ◆ Suppose Web server contains this function

```
void func(char *str) {  
    int authenticated = 0;  
    char buf[126];  
    ...  
    strcpy(buf, str);  
    ...  
}
```

- ◆ Authenticated variable non-zero when user has extra privileges
- ◆ Morris worm also overflowed a buffer to overwrite an authenticated flag in in.fingerd

Changing Flags

buf

I

- ◆ Suppose Web server contains this function

```
void func(char *str) {  
    int authenticated = 0;  
    char buf[126];  
    ...  
    strcpy(buf, str);  
    ...  
}
```

- ◆ Authenticated variable non-zero when user has extra privileges
- ◆ Morris worm also overflowed a buffer to overwrite an authenticated flag in in.fingerd

Changing Flags

buf

I (yeah!)

- ◆ Suppose Web server contains this function

```
void func(char *str) {  
    int authenticated = 0;  
    char buf[126];  
    ...  
    strcpy(buf, str);  
    ...  
}
```

- ◆ Authenticated variable non-zero when user has extra privileges
- ◆ Morris worm also overflowed a buffer to overwrite an authenticated flag in in.fingerd

Memory Layout

- ◆ **Text region:** Executable code of the program
- ◆ **Heap:** Dynamically allocated data
- ◆ **Stack:** Local variables, function return addresses; grows and shrinks as functions are called and return



Memory Layout

- ◆ **Text region:** Executable code of the program
- ◆ **Heap:** Dynamically allocated data
- ◆ **Stack:** Local variables, function return addresses; grows and shrinks as functions are called and return



Stack Buffers

- ◆ Suppose Web server contains this function

```
void func(char *str) {
    char buf[126];
    strcpy(buf, str);
}
```

Allocate local buffer (126 bytes reserved on stack)
Copy argument into local buffer

- ◆ When this function is invoked, a new **frame** with local variables is pushed onto the stack



Stack Buffers

- ◆ Suppose Web server contains this function

```
void func(char *str) {
    char buf[126];
    strcpy(buf, str);
}
```

Allocate local buffer (126 bytes reserved on stack)
Copy argument into local buffer

- ◆ When this function is invoked, a new **frame** with local variables is pushed onto the stack



Stack Buffers

- ◆ Suppose Web server contains this function

```
void func(char *str) {
    char buf[126];
    strcpy(buf, str);
}
```

Allocate local buffer (126 bytes reserved on stack)
Copy argument into local buffer

- ◆ When this function is invoked, a new **frame** with local variables is pushed onto the stack



Stack Buffers

- ◆ Suppose Web server contains this function

```
void func(char *str) {
    char buf[126];
    strcpy(buf, str);
}
```

Allocate local buffer (126 bytes reserved on stack)
Copy argument into local buffer

- ◆ When this function is invoked, a new **frame** with local variables is pushed onto the stack



Stack Buffers

- ◆ Suppose Web server contains this function

```
void func(char *str) {  
    char buf[126];  
    strcpy(buf, str);  
}
```

Allocate local buffer (126 bytes reserved on stack)
Copy argument into local buffer

- ◆ When this function is invoked, a new **frame** with local variables is pushed onto the stack

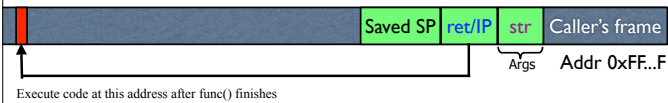

Stack Buffers

- ◆ Suppose Web server contains this function

```
void func(char *str) {  
    char buf[126];  
    strcpy(buf, str);  
}
```

Allocate local buffer (126 bytes reserved on stack)
Copy argument into local buffer

- ◆ When this function is invoked, a new **frame** with local variables is pushed onto the stack

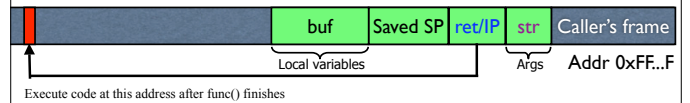

What If Buffer is Overstuffed?

- ◆ Memory pointed to by `str` is copied onto stack...

```
void func(char *str) {  
    char buf[126];  
    strcpy(buf, str);  
}
```

strcpy does NOT check whether the string at *str contains fewer than 126 characters

- ◆ If a string longer than 126 bytes is copied into buffer, it will overwrite adjacent stack locations

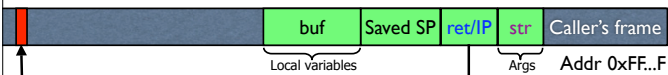

What If Buffer is Overstuffed?

- ◆ Memory pointed to by `str` is copied onto stack...

```
void func(char *str) {  
    char buf[126];  
    strcpy(buf, str);  
}
```

strcpy does NOT check whether the string at *str contains fewer than 126 characters

- ◆ If a string longer than 126 bytes is copied into buffer, it will overwrite adjacent stack locations

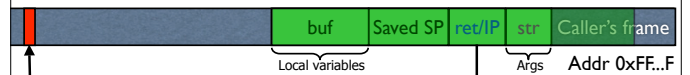

What If Buffer is Overstuffed?

- ◆ Memory pointed to by `str` is copied onto stack...

```
void func(char *str) {  
    char buf[126];  
    strcpy(buf, str);  
}
```

strcpy does NOT check whether the string at *str contains fewer than 126 characters

- ◆ If a string longer than 126 bytes is copied into buffer, it will overwrite adjacent stack locations

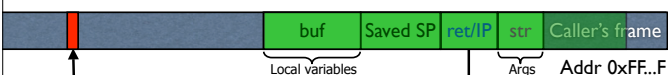

Executing Attack Code

- ◆ Suppose buffer contains attacker-created string
 - For example, `*str` contains a string received from the network as input to some network service daemon

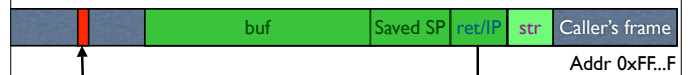

- ◆ When function exits, code in the buffer will be executed, giving attacker a shell
 - **Root shell** if the victim program is setuid root

Executing Attack Code

- ◆ Suppose buffer contains attacker-created string
 - For example, *str contains a string received from the network as input to some network service daemon

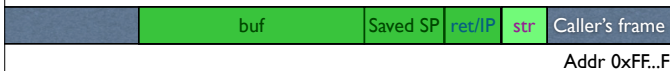

- ◆ When function exits, code in the buffer will be executed, giving attacker a shell
 - Root shell if the victim program is setuid root

Executing Attack Code

- ◆ Suppose buffer contains attacker-created string
 - For example, *str contains a string received from the network as input to some network service daemon

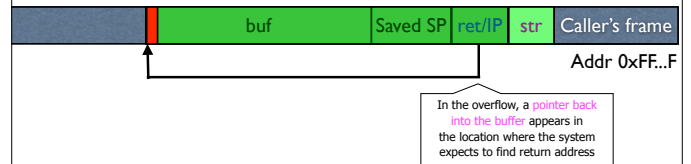

- ◆ When function exits, code in the buffer will be executed, giving attacker a shell
 - Root shell if the victim program is setuid root

Executing Attack Code

- ◆ Suppose buffer contains attacker-created string
 - For example, *str contains a string received from the network as input to some network service daemon

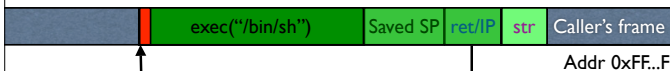

- ◆ When function exits, code in the buffer will be executed, giving attacker a shell
 - Root shell if the victim program is setuid root

Buffer Overflow Issues

- ◆ Executable attack code is stored on stack, inside the buffer containing attacker's string
 - Stack memory is supposed to contain only data, but...
- ◆ Overflow portion of the buffer must contain **correct address of attack code** in the RET position
 - The value in the RET position must point to the beginning of attack assembly code in the buffer
 - Otherwise application will crash with segmentation violation
 - Attacker must correctly guess in which stack position his buffer will be when the function is called

Problem: No Range Checking

- ◆ strcpy does not check input size
 - strcpy(buf, str) simply copies memory contents into buf starting from *str until "\0" is encountered, ignoring the size of area allocated to buf
- ◆ Many C library functions are unsafe
 - strcpy(char *dest, const char *src)
 - strcat(char *dest, const char *src)
 - gets(char *s)
 - scanf(const char *format, ...)
 - printf(const char *format, ...)

Does Range Checking Help?

- ◆ strncpy(char *dest, const char *src, size_t n)
 - If strncpy is used instead of strcpy, no more than n characters will be copied from *src to *dest
 - Programmer has to supply the right value of n
- ◆ Potential overflow in httpasswd.c (Apache 1.3):

```
strcpy(record,user);
strcat(record,":");
strcat(record,cpw); ...
```

Copies username ("user") into buffer ("record"), then appends ":" and hashed password ("cpw")

- ◆ Published "fix" (do you see the problem?):

```
... strncpy(record,user,MAX_STRING_LEN-1);
strcat(record,":");
strncat(record,cpw,MAX_STRING_LEN-1); ...
```

Misuse of strncpy in htpasswd "Fix"

- ◆ Published "fix" for Apache htpasswd overflow:

```
... strncpy(record,user,MAX_STRING_LEN-1);  
strcat(record,":");  
strncat(record,cpw,MAX_STRING_LEN-1); ...
```

MAX_STRING_LEN bytes allocated for record buffer

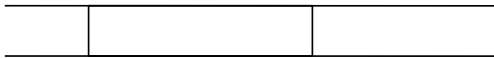

Misuse of strncpy in htpasswd "Fix"

- ◆ Published "fix" for Apache htpasswd overflow:

```
... strncpy(record,user,MAX_STRING_LEN-1);  
strcat(record,":");  
strncat(record,cpw,MAX_STRING_LEN-1); ...
```

MAX_STRING_LEN bytes allocated for record buffer

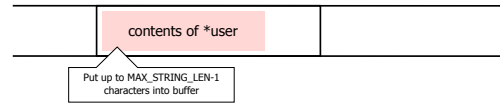

Misuse of strncpy in htpasswd "Fix"

- ◆ Published "fix" for Apache htpasswd overflow:

```
... strncpy(record,user,MAX_STRING_LEN-1);  
strcat(record,":");  
strncat(record,cpw,MAX_STRING_LEN-1); ...
```

MAX_STRING_LEN bytes allocated for record buffer

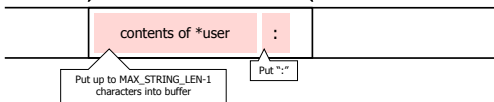

Misuse of strncpy in htpasswd "Fix"

- ◆ Published "fix" for Apache htpasswd overflow:

```
... strncpy(record,user,MAX_STRING_LEN-1);  
strcat(record,":");  
strncat(record,cpw,MAX_STRING_LEN-1); ...
```

MAX_STRING_LEN bytes allocated for record buffer

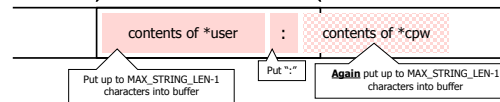

Off-By-One Overflow

- ◆ Home-brewed range-checking string copy

```
void notSoSafeCopy(char *input) {  
    char buffer[512]; int i;  
    for (i=0; i<=512; i++)  
        buffer[i] = input[i];  
}  
void main(int argc, char *argv[]) {  
    if (argc==2)  
        notSoSafeCopy(argv[1]);  
}
```

Off-By-One Overflow

- ◆ Home-brewed range-checking string copy

```
void notSoSafeCopy(char *input) {  
    char buffer[512]; int i;  
    for (i=0; i<=512; i++)  
        buffer[i] = input[i];  
}  
void main(int argc, char *argv[]) {  
    if (argc==2)  
        notSoSafeCopy(argv[1]);  
}
```

This will copy 513 characters into buffer. Oops!

Off-By-One Overflow

- ◆ Home-brewed range-checking string copy

```
void notSoSafeCopy(char *input) {
    char buffer[512]; int i;
    for (i=0; i<=512; i++)
        buffer[i] = input[i];
}
void main(int argc, char *argv[]) {
    if (argc==2)
        notSoSafeCopy(argv[1]);
}
```

This will copy 513 characters into buffer. Oops!

- ◆ 1-byte overflow: can't change RET, but can change pointer to previous stack frame
 - On little-endian architecture, make it point into buffer
 - RET for previous function will be read from buffer!

Memory Layout

- ◆ **Text region**: Executable code of the program
- ◆ **Heap**: Dynamically allocated data
- ◆ **Stack**: Local variables, function return addresses; grows and shrinks as functions are called and return



Heap Overflow

- ◆ Overflowing buffers on heap can change pointers that point to important data
 - Sometimes can also transfer execution to attack code
 - Can cause program to crash by forcing it to read from an invalid address (segmentation violation)
- ◆ **Illegitimate privilege elevation**: if program with sysadm/root rights, attacker can use it to write into a normally inaccessible file
 - For example, replace a filename pointer with a pointer into buffer location containing name of a system file
 - Instead of temporary file, write into AUTOEXEC.BAT

Function Pointer Overflow

- ◆ C uses **function pointers** for callbacks: if pointer to F is stored in memory location P, then another function G can call F as (*P)(...)

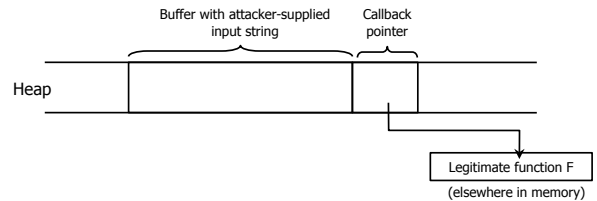

Function Pointer Overflow

- ◆ C uses **function pointers** for callbacks: if pointer to F is stored in memory location P, then another function G can call F as (*P)(...)

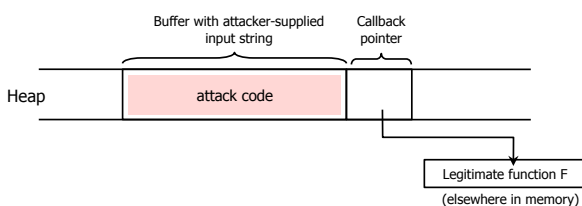

Function Pointer Overflow

- ◆ C uses **function pointers** for callbacks: if pointer to F is stored in memory location P, then another function G can call F as (*P)(...)

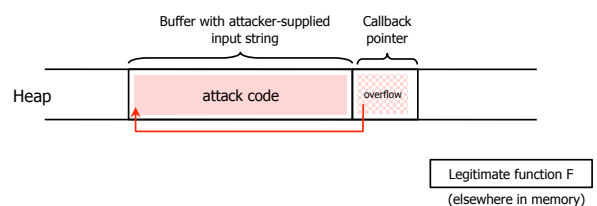

Format Strings in C

◆ Proper use of printf format string:

```
... int foo=1234;
... printf("foo = %d in decimal, %X in hex",foo,foo); ...
- This will print
    foo = 1234 in decimal, 4D2 in hex
```

◆ Sloppy use of printf format string:

```
... char buf[13]="Hello, world!";
... printf(buf);
// should've used printf("%s", buf); ...
```

- If buffer contains format symbols starting with %, location pointed to by printf's internal stack pointer will be interpreted as an argument of printf. This can be exploited to [move printf's internal stack pointer](#).

Viewing Memory

◆ %x format symbol tells printf to output data on stack

```
... printf("Here is an int: %x",i); ...
```

◆ What if printf does not have an argument?

```
... char buf[16]="Here is an int: %x";
... printf(buf); ...
```

- Stack location pointed to by printf's internal stack pointer will be interpreted as an int. (What if crypto key, password, ...?)

◆ Or what about:

```
... char buf[16]="Here is a string: %s";
... printf(buf); ...
```

- Stack location pointed to by printf's internal stack pointer will be interpreted as a pointer to a string

Writing Stack with Format Strings

◆ %n format symbol tells printf to write the number of characters that have been printed

```
... printf("Overflow this!%n", &myVar); ...
```

- Argument of printf is interpreted as destination address
- This writes 14 into myVar ("Overflow this!" has 14 characters)

◆ What if printf does not have an argument?

```
... char buf[16]="Overflow this!%n";
... printf(buf); ...
```

- Stack location pointed to by printf's internal stack pointer will be interpreted as address into which the number of characters will be written.

More Buffer Overflow Targets

◆ Heap management structures used by malloc()

◆ URL validation and canonicalization

- If Web server stores URL in a buffer with overflow, then attacker can gain control by supplying malformed URL
 - Nimda worm propagated itself by utilizing buffer overflow in Microsoft's Internet Information Server

◆ Some attacks don't even need overflow

- Naïve security checks may miss URLs that give attacker access to forbidden files
 - For example, `http://victim.com/user/../../../../autoexec.bat` may pass naïve check, but give access to system file
 - Defeat checking for "/" in URL by using hex representation: %5c or %255c.

Preventing Buffer Overflow

◆ Use safe programming languages, e.g., Java

- What about legacy C code?

◆ Mark stack as non-executable

◆ Randomize stack location or encrypt return address on stack by XORing with random string

- Attacker won't know what address to use in his or her string

◆ Static analysis of source code to find overflows

◆ Run-time checking of array and buffer bounds

- StackGuard, libsafe, many other tools

◆ Black-box testing with long strings

Non-Executable Stack

◆ NX bit on every Page Table Entry

- AMD Athlon 64, Intel P4 "Prescott"
- Code patches marking stack segment as non-executable exist for Linux, Solaris, OpenBSD

◆ Some applications need executable stack

- For example, LISP interpreters

◆ Does not defend against return-to-libc exploits

- Overwrite return address with the address of an existing library function (can still be harmful)

◆ ...nor against heap and function pointer overflows

◆ ...nor changing stack internal variables (auth flag, ...)

Run-Time Checking: StackGuard

- ◆ Embed "canaries" in stack frames and verify their integrity prior to function return
 - Any overflow of local variables will damage the canary

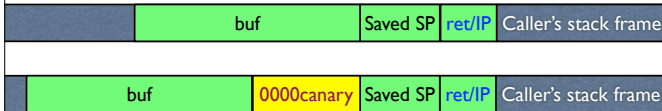

- ◆ Choose random canary string on program start
 - Attacker can't guess what the value of canary will be
- ◆ Terminator canary: "\0", newline, linefeed, EOF
 - String functions like strcpy won't copy beyond "\0"

Run-Time Checking: StackGuard

- ◆ Embed "canaries" in stack frames and verify their integrity prior to function return
 - Any overflow of local variables will damage the canary



- ◆ Choose random canary string on program start
 - Attacker can't guess what the value of canary will be
- ◆ Terminator canary: "\0", newline, linefeed, EOF
 - String functions like strcpy won't copy beyond "\0"

Run-Time Checking: StackGuard

- ◆ Embed "canaries" in stack frames and verify their integrity prior to function return
 - Any overflow of local variables will damage the canary

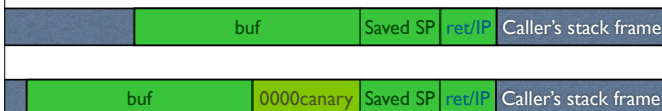

- ◆ Choose random canary string on program start
 - Attacker can't guess what the value of canary will be
- ◆ Terminator canary: "\0", newline, linefeed, EOF
 - String functions like strcpy won't copy beyond "\0"

Run-Time Checking: StackGuard

- ◆ Embed "canaries" in stack frames and verify their integrity prior to function return
 - Any overflow of local variables will damage the canary

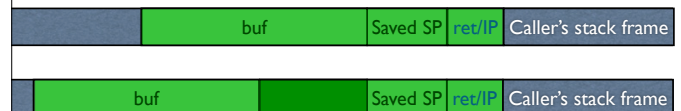

- ◆ Choose random canary string on program start
 - Attacker can't guess what the value of canary will be
- ◆ Terminator canary: "\0", newline, linefeed, EOF
 - String functions like strcpy won't copy beyond "\0"

StackGuard Implementation

- ◆ StackGuard requires code recompilation
- ◆ Checking canary integrity prior to every function return causes a performance penalty
 - For example, 8% for Apache Web server
- ◆ PointGuard also places canaries next to function pointers and setjmp buffers
 - Worse performance penalty
- ◆ StackGuard can be defeated!
 - Phrack article by Bulba and Kil3r

Defeating StackGuard (Sketch)

- ◆ Idea: overwrite pointer used by some strcpy and make it point to return address (RET) on stack
 - strcpy will write into RET without touching canary!

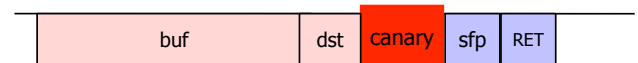

Suppose program contains `strcpy(dst,buf)` Return execution to this address

Defeating StackGuard (Sketch)

- ◆ Idea: overwrite pointer used by some strcpy and make it point to return address (RET) on stack
 - strcpy will write into RET without touching canary!

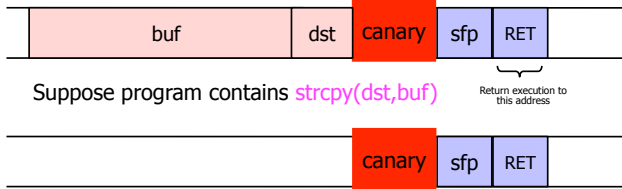

Defeating StackGuard (Sketch)

- ◆ Idea: overwrite pointer used by some strcpy and make it point to return address (RET) on stack
 - strcpy will write into RET without touching canary!

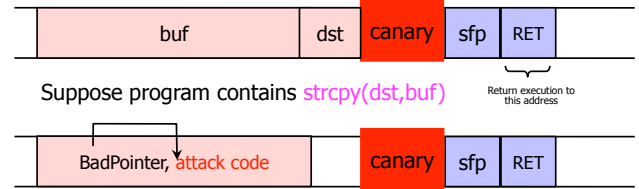

Defeating StackGuard (Sketch)

- ◆ Idea: overwrite pointer used by some strcpy and make it point to return address (RET) on stack
 - strcpy will write into RET without touching canary!

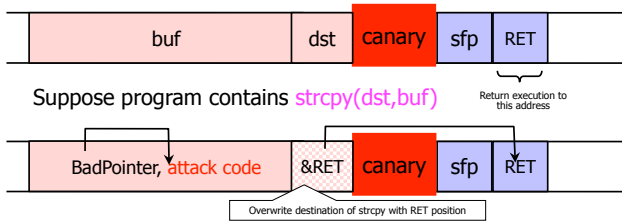

Defeating StackGuard (Sketch)

- ◆ Idea: overwrite pointer used by some strcpy and make it point to return address (RET) on stack
 - strcpy will write into RET without touching canary!

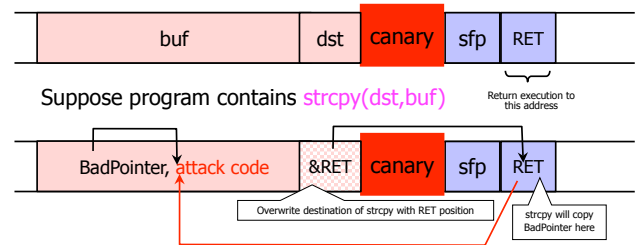

Run-Time Checking: Libsafe

- ◆ Dynamically loaded library
- ◆ Intercepts calls to `strcpy(dest,src)`
 - Checks if there is sufficient space in current stack frame

$$|\text{frame-pointer} - \text{dest}| > \text{strlen}(\text{src})$$
 - If yes, does strcpy; else terminates application

PointGuard

- ◆ Attack: overflow a function pointer so that it points to attack code
- ◆ Idea: encrypt all pointers while in memory
 - Generate a random key when program is executed
 - Each pointer is XORed with this key when loaded from memory to registers or stored back into memory
 - Pointers cannot be overflowed while in registers
- ◆ Attacker cannot predict the target program's key
 - Even if pointer is overwritten, after XORing with key it will dereference to a "random" memory address

Normal Pointer Dereference [Cowan]

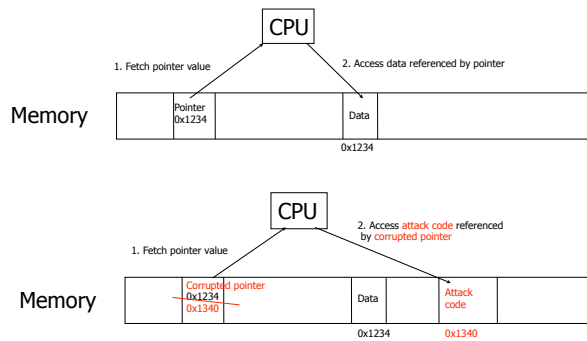

PointGuard Dereference [Cowan]

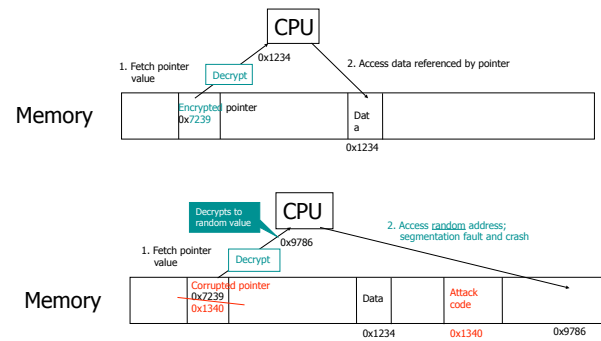

PointGuard Issues

- ◆ Must be very fast
 - Pointer dereferences are very common
- ◆ Compiler issues
 - Must encrypt and decrypt only pointers
 - If compiler "spills" registers, unencrypted pointer values end up in memory and can be overwritten there
- ◆ Attacker should not be able to modify the key
 - Store key in its own non-writable memory page
- ◆ PG'd code doesn't mix well with normal code
 - What if PG'd code needs to pass a pointer to OS kernel?

Integer Overflow and Implicit Cast

```
char buf[80];
void vulnerable() {
    int len = read_int_from_network();
    char *p = read_string_from_network();
    if (len > sizeof buf) {
        error("length too large, nice try!");
        return;
    }
    memcpy(buf, p, len);
}
```

- ◆ If `len` is negative, may copy huge amounts of input into `buf`

(from www-inst.eecs.berkeley.edu/~impl/flaws.pdf)

Integer Overflow and Implicit Cast

```
char buf[80];
void vulnerable() {
    int len = read_int_from_network();
    char *p = read_string_from_network();
    if (len > sizeof buf) {
        error("length too large, nice try!");
        return;
    }
    memcpy(buf, p, len);
}

void *memcpy(void *dst, const void *src, size_t n);
typedef unsigned int size_t;
```

- ◆ If `len` is negative, may copy huge amounts of input into `buf`

(from www-inst.eecs.berkeley.edu/~impl/flaws.pdf)

Integer Overflow and Implicit Cast

```
size_t len = read_int_from_network();
char *buf;
buf = malloc(len+5);
read(fd, buf, len);
```

- ◆ What if `len` is large (e.g., `len = 0xFFFFFFFF`)?
- ◆ Then `len + 5 = 4` (on many platforms)
- ◆ Result: Allocate a 4-byte buffer, then read a lot of data into that buffer.

(from www-inst.eecs.berkeley.edu/~impl/flaws.pdf)

TOCTOU

- ◆ TOCTOU == Time of Check to Time of Use

```
int openfile(char *path) {
    struct stat s;
    if (stat(path, &s) < 0)
        return -1;
    if (!S_ISREG(s.st_mode)) {
        error("only allowed to regular files!");
        return -1;
    }
    return open(path, O_RDONLY);
}
```

- ◆ Goal: Open only regular files (not symlink, etc)
- ◆ Attacker can change meaning of `path` between `stat` and `open` (and access files he or she shouldn't)

Randomness issues

- ◆ Many applications (especially security ones) require randomness
- ◆ "Obvious" uses:
 - Generate secret cryptographic keys
 - Generate random initialization vectors for encryption
- ◆ Other "non-obvious" uses:
 - Generate passwords for new users
 - Shuffle the order of votes (in an electronic voting machine)
 - Shuffle cards (for an online gambling site)

C's rand() Function

- ◆ C has a built-in random function: `rand()`

```
unsigned long int next = 1;
/* rand: return pseudo-random integer on 0..32767 */
int rand(void) {
    next = next * 1103515245 + 12345;
    return (unsigned int)(next/65536) % 32768;
}
/* srand: set seed for rand() */
void srand(unsigned int seed) {
    next = seed;
}
```

- ◆ Problem: don't use `rand()` for security-critical applications!
 - Given a few sample outputs, you can predict subsequent ones

Dr.Dobb's Portal
The World of Software Development

ABOUT US | CONTACT | ADVERTISE | SUBSCRIBE | SOURCE CODE | CURRENT PRINT ISSUE
NEWSLETTERS | RESOURCES | BLOGS | PODCASTS | CAREERS

Windows/.NET

July 22, 2001

Randomness and the Netscape Browser

How secure is the World Wide Web?

Ian Goldberg and David Wagner

No one was more surprised than Netscape Communications when a pair of computer-science students broke the Netscape encryption scheme. Ian and David describe how they attacked the popular Web browser and what they found out.

• Email • Print
• Discuss • Reply
add to:
Del.icio.usSlash
• Digg • Y! |
• Google MyWe
• Spurl • Blin
• Furl

Problems in Practice

- ◆ One institution used (something like) `rand()` to generate passwords for new users
 - Given your password, you could predict the passwords of other users
- ◆ Kerberos (1988 - 1996)
 - Random number generator improperly seeded
 - Possible to trivially break into machines that rely upon Kerberos for authentication
- ◆ Online gambling websites
 - Random numbers to shuffle cards
 - Real money at stake
 - But what if poor choice of random numbers?



Images from <http://www.cigital.com/news/index.php?pg=art&artid=20>

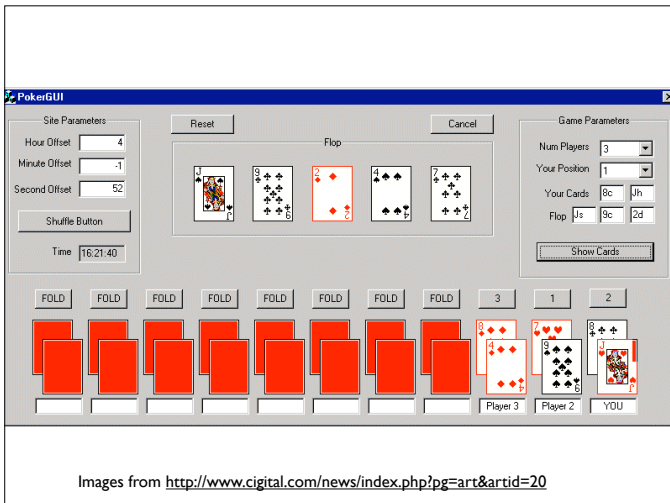

Obtaining Pseudorandom Numbers

- ◆ For security applications, want “cryptographically secure pseudorandom numbers”
- ◆ Libraries include:
 - OpenSSL
 - CryptoAPI (Microsoft)
- ◆ Linux:
 - /dev/random
 - /dev/urandom
- ◆ Internally:
 - Pool from multiple sources (interrupt timers, keyboard, ...)
 - Physical sources (radioactive decay, ...)

Security Analyses

- ◆ Recall
 - Assets: What you are protecting
 - Security Goals
 - Confidentiality
 - Integrity
 - Availability
 - Adversaries: Who might try to attack the system
 - Threats: What they might try to do
 - Potential Vulnerabilities: Possible weaknesses in system
 - Protection mechanisms: How to protect/deter attacks
- ◆ Last time: Voting machines

Your Turn

- ◆ Talk amongst your neighbors (2 to 3 people per group)
- ◆ Consider one (or two) of the following products:
 - ~~[[Removed before posting online]]~~
 - Product of your choice
- ◆ Write-down (around 1 - 3 sentences for each)
 - Summary of product
 - 2 - 3 assets + security goals
 - 2 - 3 adversaries + threats
 - 2 - 3 potential weaknesses + protection mechanisms
- ◆ We'll discuss in N minutes. Turn in papers at end of class for extra credit. (1 per group; names/student IDs at top.) I have paper.

Reading Assignment

- ◆ Chapter 11 of Stamp
- ◆ Read [Smashing the Stack for Fun and Profit](#) to understand details of overflow exploits
 - Will [really](#) help with the project without it!
- ◆ Read [Exploiting Format String Vulnerabilities](#)
- ◆ Read [Blended Attacks](#) by Chien and Szor to better understand buffer overflows