

Networking

More than just a social interaction

© 2004 Lawrence Snyder

1



Networks...

Computers are useful alone, but are better when connected (networked)

- * Access more information and software than is stored locally
- * Help users to communicate, exchange information ... changing ideas about social interaction
- * Perform other services -- printing, Web,...

UW's networks move more than trillion bytes per day



Networking Changes Life

The Internet is making fundamental changes ... The *FIT* text gives 5 ways

- Nowhere is remote -- access to info is no longer bound to a place
- Connecting with others -- email is great
- Revised human relationships -- too much time spent online could be bad
- English becoming a universal language
- Enhanced freedom of speech, assembly

Can you think of others?

3



Network Structure

Networks are structured differently based (mostly) on how far apart the computers are

- * Local area network (LAN) -- a small area such as a room or building
- * Wide area networks (WAN) -- large area, e.g. distance is more than 1 Km

Internet: all of the wires, fibers, switches, routers etc. connecting named computers

4



Protocol Rules!

To communicate computers need to know how to set-up the info to be sent and interpret the info received

- * Communication rules are a *protocol*
- * Example protocols
 - EtherNet for physical connection in a LAN
 - TCP/IP -- transmission control protocol / internet protocol -- for Internet
 - HTTP -- hypertext transfer protocol -- for Web

5



LAN in the Lab

EtherNet is a popular LAN protocol

- Recall, it's a "party" protocol

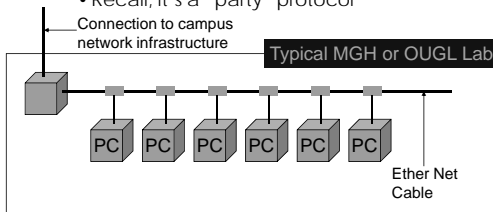

6



Campus & The World

The campus subnetworks interconnect computers of the UW domain which connects to Internet via a gateway

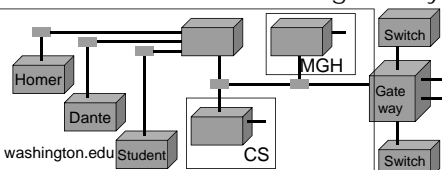

All communication by TCP/IP



IP -- Like Using Postcards

Information is sent across the Internet using IP -- Cerf uses postcard analogy

- Break message into fixed size units
- Form IP packets with destination address, sequence number and content **addr#data**
- Each makes its way separately to destination, possibly taking different routes
- Reassembled at destination forming msg

Taking separate routes lets packets by-pass congestion and out-of-service switches



A Trip to Switzerland

A packet sent from UW to ETH (Swiss Fed. Tech. University) took 21 hops

Hop	IP Address	Node Name	Location	ms	Network
0	128.95.1.107	surf-cse.washington.edu	University of Washington	0	University of Washington WASHINGTON
1	128.95.1.100	lucd2-001-1.cse.washington.edu	University of Washington	0	University of Washington WASHINGTON
2	143.142.150	lucd2-001-1.cse.washington.edu	University of Washington	0	University of Washington WASHINGTON
3	198.107.150	lucd2-001-1.cse.washington.edu	University of Washington	0	University of Washington WASHINGTON
4	198.48.81.78	adslme-gw-pgw-gigaset.net	University of Washington	0	University of Washington WASHINGTON
5	198.32.15.130	adslme-gw-pgw-gigaset.net	University of Washington	0	University of Washington WASHINGTON
6	198.32.8.60	adslme-gw-pgw-gigaset.net	University of Washington	0	University of Washington WASHINGTON
7	198.32.15.115	adslme-gw-pgw-gigaset.net	University of Washington	0	University of Washington WASHINGTON
8	198.32.8.14	adslme-gw-pgw-gigaset.net	University of Washington	0	University of Washington WASHINGTON
9	198.32.15.110	adslme-gw-pgw-gigaset.net	University of Washington	0	University of Washington WASHINGTON
10	198.32.8.89	adslme-gw-pgw-gigaset.net	University of Washington	0	University of Washington WASHINGTON
11	198.32.15.116	adslme-gw-pgw-gigaset.net	University of Washington	0	University of Washington WASHINGTON
12	198.32.8.83	adslme-gw-pgw-gigaset.net	University of Washington	0	University of Washington WASHINGTON
13	198.32.8.85	adslme-gw-pgw-gigaset.net	University of Washington	0	University of Washington WASHINGTON
14	62.40.153.25	adslme-gw-pgw-gigaset.net	University of Washington	0	University of Washington WASHINGTON
15	62.40.153.25	adslme-gw-pgw-gigaset.net	University of Washington	0	University of Washington WASHINGTON
16	62.40.153.25	adslme-gw-pgw-gigaset.net	University of Washington	0	University of Washington WASHINGTON
17	62.40.153.18	adslme-gw-pgw-gigaset.net	University of Washington	0	University of Washington WASHINGTON
18	170.150.26.42	adslme-gw-pgw-gigaset.net	University of Washington	0	University of Washington WASHINGTON
19	192.23.82.1	adslme-gw-pgw-gigaset.net	University of Washington	0	University of Washington WASHINGTON
20	129.133.100.10	adslme-gw-pgw-gigaset.net	University of Washington	0	University of Washington WASHINGTON
21	129.133.100.10	adslme-gw-pgw-gigaset.net	University of Washington	0	University of Washington WASHINGTON

UW Gateway



Check Internet Hops

Interested?

- * Find software called Visual Routes (personal evaluation copies are free) at <http://www.visualroute.com>
- * Download a copy of the software
- * Install software and type in foreign URLs
 - Switzerland eth.ch
 - Australia www.usyd.edu.au
 - Japan kyoto-u.ac.jp
 - South Africa www.uct.ac.za

Use Google to find foreign computers



Naming Computers I

People name computers by a domain name -- a hierarchical scheme that groups like computers

- .edu All educational computers
- .washington.edu All computers at UW
 - dante.washington.edu A UW computer
- .ischool.washington.edu iSchool computers
- .cs.washington.edu CSE computers
 - june.cs.washington.edu A CSE computer

Peers

Domains begin with a "dot" and get "larger" going right



Naming Computers II

Computers are named by IP address, four numbers in the range 0-255

cse.washington.edu: 128.95.1.4
ischool.washington.edu: 128.208.100.150

- * Remembering IP addresses would be brutal for humans, so we use domains
- * Computers find the IP address for a domain name from the *Domain Name System* -- an IP address-book computer

A computer needs to know IP address of DNS server!



Domains

.edu .com .mil .gov .org .net domains are "top level domains" for the US

- * Recently, new TLD names added
- * Each country has a top level domain name: .ca (Canada), .es (Spain), .de (Germany), .au (Australia), .at (Austria), .us

The FIT book contains the complete list

13



Logical vs Physical

There are 2 ways to view the Internet

- Humans see a hierarchy of domains relating computers -- logical network
- Computers see groups of four number IP addresses -- physical network
- Both are ideal for the "users" needs
- The Domain Name System (DNS) relates the logical network to the physical network by translating domains to IP addresses

14



Client/Server Structure

The Internet computers rely on the client/server protocol: servers provide services, clients use them

- Sample servers: *email server, web server, ...*
- UW servers: *dante, courses, www, student, ...*
- Frequently, a "server" is actually many computers acting as one, e.g. *dante* is a group of more than 50 servers

Protocol: Client packages a request, and sends it to a server; Server does the service and sends a reply



World Wide Web

World Wide Web is the collection of servers (subset of Internet computers) & the information they give access to

- Clearly, WWW ≠ Internet
- The "server" is the web site computer and the "client" is the surfer's browser
- Many Web server's domain names begin with *www* by tradition, but any name is OK
- Often multiple server names map to the same site: *MoMA.org* and *www.MoMA.org*

16



Client/Server Interaction

For Web pages, the client requests a page, the server returns it: there's no connection, just two transmissions

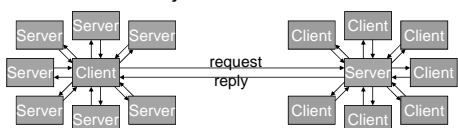

Servers serve many clients; clients visit many servers



Dissecting a URL

Web addresses are URLs, *uniform resource locator*, an IP address+path

- URLs are often *redirected* to other places; e.g. *http://www.cs.washington.edu/100/* goes to *http://www.cs.washington.edu/education/courses/100/04wi/index.htm*

protocol	= http://
Web server	= www
domain	= .cs.washington.edu
path	= /education/courses/100/04wi/ <i>directories (folders)</i>
file	= index
file extension	= .htm <i>hypertext markup language</i>

18



FIT100

Summary

Networking is changing the world

Internet: named computers using TCP/IP

WWW: servers providing access to info

* Principles

- Logical network of domain names
- Physical network of IP addresses
- Protocols rule: LAN, TCP/IP, http, ...
- Domain Name System connects the two
- Client/Server, fleeting relationship on WWW

19