

Control unit extension for data hazards

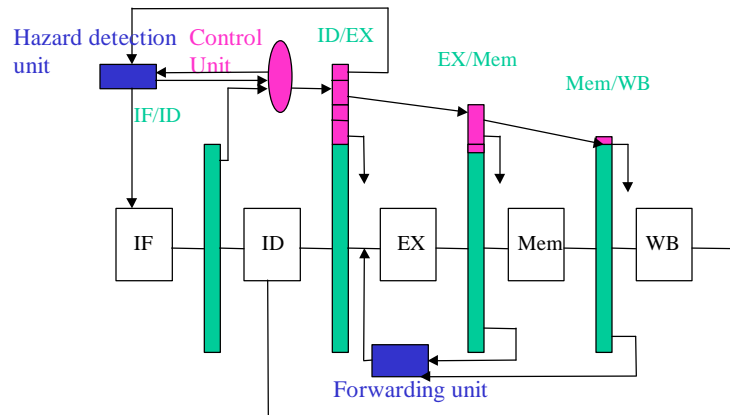

2/15/99

CSE378 Pipelining hazards

1

Forwarding unit

- Forwarding is done prior to ALU computation in EX stage
- If we have an R-R instruction, the forwarding unit will need to check
 - whether EX/Mem result register = IF/ID rs
 - EX/Mem result register = IF/ID rt
 - and if so set up muxes to ALU source appropriately
- and also whether
 - Mem/WB result register = IF/ID rs
 - Mem/WB result register = IF/ID rt
 - and if so set up muxes to ALU source appropriately

2/15/99

CSE378 Pipelining hazards

2

Forwarding unit (ct'd)

- For a Load/Store or Immediate instruction
 - Need to check forwarding for rs only
- For a branch instruction
 - Need to check forwarding for the registers involved in the comparison

2/15/99

CSE378 Pipelining hazards

3

Forwarding in consecutive instructions

- What happens if we have

add \$10,\$10,\$12

add \$10,\$10,\$12

add \$10,\$10,\$12

Forwarding priority is given to the most recent result, that is the one generated by the ALU in the EX/Mem, not the one passed to Mem/Wb

2/15/99

CSE378 Pipelining hazards

4

Hazard detection unit

- If a Load (instruction $i-1$) is followed by instruction i that needs the result of the load, we need to stall the pipeline for one cycle, that is
 - instruction $i-1$ should progress normally
 - instruction i should not progress
 - no new instruction should be fetched
- The hazard detection unit should operate during the ID stage
- How do we know instruction $i-1$ is a Load
 - Memread signal asserted in ID/EX

2/15/99

CSE378 Pipelining hazards

5

Hazard detection unit (c'd)

- How do we know we should stall
 - instruction $i-1$ is a Load and either
 - ID/EX $rt =$ IF/ID rs
 - or ID/EX $rt =$ IF/ID rt
- How do we prevent instruction i to progress
 - Put 0's in all control fields of ID/EX (becomes a no-op)
 - Don't change the IF/ID field (have a control line be asserted at every cycle to write it unless we have to stall)
- How do we prevent fetching a new instruction
 - Have a control line asserted only when we want to write a new value in the PC

2/15/99

CSE378 Pipelining hazards

6

Control hazards

- Pipelining and branching don't get along
- Transfer of control (jumps, procedure call/returns, successful branches) cause control hazards
- When a branch is known to succeed, at the Mem stage, there are instructions in the pipeline that are the instructions
 - We'll need to convert these instructions into "no-op"
 - We'll need to start fetching the correct instructions by using the right PC

2/15/99

CSE378 Pipelining hazards

7

Example of control hazard

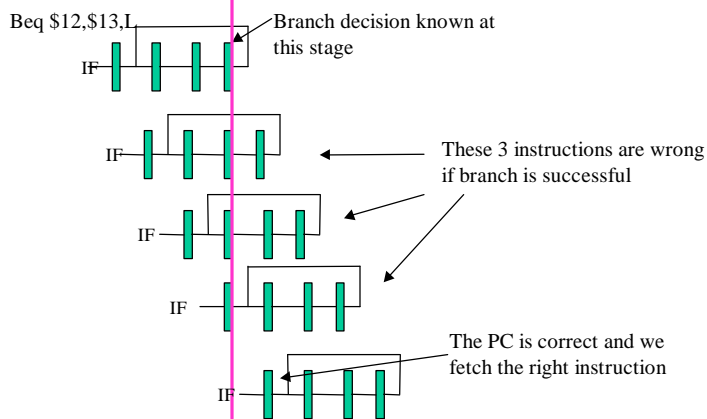

2/15/99

CSE378 Pipelining hazards

8

Resolving control hazards

- Detecting a potential control hazard is easy
 - Look at the opcode
- We must insure that the state of the program is not changed until the outcome of the branch is known. Possibilities are:
 - Stall as soon as opcode is detected (cost 3 bubbles; same type of logic as for the load stall but for 3 cycles instead of one)
 - Assume that branch won't be taken (cost only if branch is taken; see next slides)
 - Use some predictive techniques

2/15/99

CSE378 Pipelining hazards

9

Assume branch not taken strategy

- We have a problem if branch is taken!
- “No-op” the “wrong” instructions
 - Once the new PC is known (in Mem stage)
 - Zero out the instruction field in the IF/ID pipeline register
 - For the instruction in the ID stage, use the stall signals that were set-up for data dependencies in the Load case
 - For the instruction in the EX stage, zero out the result of the ALU (e.g. make the result register be register \$0)

2/15/99

CSE378 Pipelining hazards

10

Optimizations

- Move up the result of branch execution
 - Do target address computation in ID stage (like in multiple cycle implementation)
 - Comparing registers is “fast”; can be done in first phase of the clock and setting PC in the second phase.
 - Thus we can reduce stalling time by 1 bubble
- In the book, they reduce it by 2 bubbles but....
 - The organization as shown is slightly flawed (they forgot about extra complications in forwarding)

2/15/99

CSE378 Pipelining hazards

11

Branch prediction

- Instead of assuming “branch not taken” you can have a table keeping the history of past branches
 - We’ll see how to build such tables when we study caches
 - History can be restricted to 2-bit “saturating counters” such that it takes two wrong prediction outcomes before changing your prediction
 - If predicted taken, will need only 1 bubble since PC can be computed during ID stage.
 - There even exists schemes where you can predict and not lose any cycle on predicted take, of course if the prediction is correct
- Note that if prediction is incorrect, you need to flush the pipe as before

2/15/99

CSE378 Pipelining hazards

12

Current trends in microprocessor design

- *Superscalar* processors
 - Several pipelines, e.g., integer pipeline(s), floating-point, load/store unit etc
 - Several instructions are fetched and decoded at once. They can be executed concurrently if there are no hazards
- *Out-of-order execution* (also called dynamically scheduled processors)
 - While some instructions are stalled because of dependencies or other causes (cache misses, see later), other instructions down the stream can still proceed.
 - However results must be stored in program order!

2/15/99

CSE378 Pipelining hazards

13

Current trends (ct's)

- *Speculative execution*
 - Predict the outcome of branches and continue processing with (of course) a recovery mechanism.
 - Because branches occur so often, the branch prediction mechanisms have become very sophisticated
- *VLIW (or EPIC) (Very Long Instruction Word)*
 - Each pipeline (functional unit) is assigned a task at every cycle. The compiler does it.

2/15/99

CSE378 Pipelining hazards

14