

# Deadlock

CSE 410, Spring 2007  
Computer Systems

<http://www.cs.washington.edu/410>

# Readings and References

- Reading
  - » Chapter 8, *Operating System Concepts*, Silberschatz, Galvin, and Gagne
- Other References

# Deadlock

- Circular waiting for resources
  - » Task A wants what task B has
  - » Task B wants what task A has
- No progress possible!
  - » Neither can make progress without the other's resource
  - » Neither will relinquish its own resource

```
...  
lockOne->Acquire();  
...  
lockTwo->Acquire();  
...  
lockTwo->Acquire();
```

```
...  
lockTwo->Acquire();  
lockOne->Acquire();
```

**DEADLOCK!**

# Simple Traffic Gridlock Example

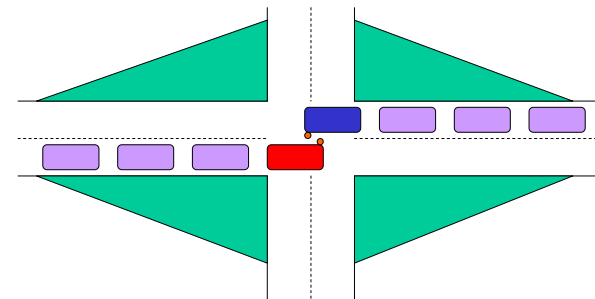

## System Model

- There are *tasks* and *resources*
- A task follows these steps to utilize a resource
  - » Acquire the resource
    - If the resource is unavailable, block
  - » Use the resource
  - » Release the resource

5/17/2007

cse410-25-deadlock © 2006-07 Perkins, DW Johnson and University of Washington

5

## Necessary Conditions for Deadlock

- Mutual Exclusion
  - » The resource can't be shared
- Hold and Wait
  - » Task holds one resource while waiting for another
- No Preemption
  - » If a task has a resource, it cannot be forced to give it up
- Circular Wait
  - » A waits for B, B for C, C for D, D for A

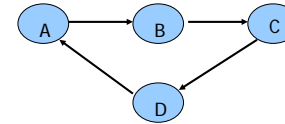

## Is Gridlock an Example of Deadlock?

- Mutual Exclusion
  - » space-time can only hold one car at a time
- Hold and wait
  - » I'm here, and I want to turn left, so watch out
- No preemption
  - » cannons are not allowed in cars at this time
- Circular wait
  - » blue is waiting for red's space and vice versa

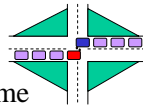

5/17/2007

cse410-25-deadlock © 2006-07 Perkins, DW Johnson and University of Washington

7

## Dealing with Deadlock

- Deadlock Prevention
  - » Ensure statically that deadlock is impossible
- Deadlock Avoidance
  - » Ensure dynamically that deadlock is impossible
- Deadlock Detection and Recovery
  - » Allow deadlock to occur, but notice when it does and try to recover
- Ignore the Problem
  - » Let the operator untangle it, that's what they're paid for

5/17/2007

cse410-25-deadlock © 2006-07 Perkins, DW Johnson and University of Washington

8

## Deadlock Prevention

- There are four necessary conditions for deadlock
- Take any one of them away and deadlock is impossible
- Let's attack deadlock by
  - » examining each of the conditions
  - » considering what would happen if we threw it out

5/17/2007

cse410-25-deadlock © 2006-07 Perkins, DW Johnson and University of Washington

9

## Condition: Mutual Exclusion

- Usually can't eliminate this condition
  - » some resources are intrinsically non-sharable
- Examples include printer, write access to a file or record, entry into a section of code
- However, you can often mitigate this by adding a layer of abstraction
  - » For example, write to a queue of jobs for a shared resource instead of locking the resource to write

5/17/2007

cse410-25-deadlock © 2006-07 Perkins, DW Johnson and University of Washington

10

## Condition: Hold and Wait

- Eliminate partial acquisition of resources
- Task must acquire all the resources it needs before it does anything
  - » if it can't get them all, then it gets none
- Issue: Resource utilization may be low
  - » If you need P for a long time and Q only at the end, you still have to hold Q's lock the whole time
- Issue: Starvation prone
  - » May have to wait indefinitely before popular resources are all available at the same time

5/17/2007

cse410-25-deadlock © 2006-07 Perkins, DW Johnson and University of Washington

11

## Condition: No Preemption

- Allow preemption
  - » If a process asks for a resource not currently available, block it and take away all of its other resources
  - » Add the preempted resources to the list of resources the process is waiting for
- This strategy works for some resources:
  - » CPU state (contents of registers can be spilled to memory)
  - » memory (can be spilled to disk)
- But not for others:
  - » printer - rip off the existing printout and tape it on later?

5/17/2007

cse410-25-deadlock © 2006-07 Perkins, DW Johnson and University of Washington

12

## Condition: Circular Wait

- To attack the circular wait condition:
  - » Assign each resource a priority
  - » Make processes acquire resources in priority order
- Two processes need the printer and the scanner, both must acquire the printer (higher priority) before the scanner
- This is a common form of deadlock prevention
- The only problem: sometimes forced to relinquish a resource that you thought you had locked up

5/17/2007

cse410-25-deadlock © 2006-07 Perkins, DW Johnson and University of Washington

13

## Deadlock Avoidance

- Deadlock prevention is often too strict
  - » low device utilization
  - » reduced system throughput
- If the OS had more information, it could do more sophisticated things to avoid deadlock and keep the system in a safe state
  - » “If” is a little word, but it packs a big punch
  - » predicting all needed resources *a priori* is hard

5/17/2007

cse410-25-deadlock © 2006-07 Perkins, DW Johnson and University of Washington

14

## The Banker's Algorithm

- Idea: know what each process *might* ask for
- Only make allocations that leave the system in a *safe* state
- Inefficient

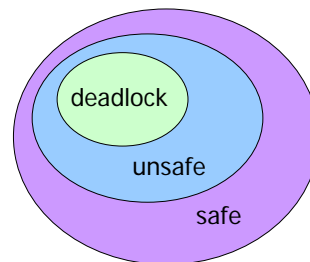

Resource allocation  
state space

5/17/2007

cse410-25-deadlock © 2006-07 Perkins, DW Johnson and University of Washington

15

## Deadlock Detection

- Build a *wait-for* graph and periodically look for cycles, to find the circular wait condition
- The wait-for graph contains:
  - » nodes, corresponding to tasks
  - » directed edges, corresponding to a resource held by one task and desired by the other

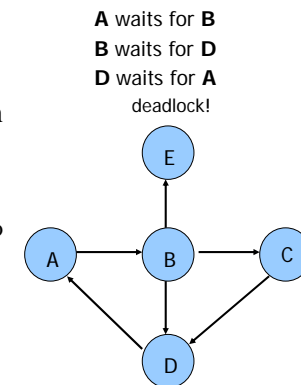

5/17/2007

cse410-25-deadlock © 2006-07 Perkins, DW Johnson and University of Washington

16

## Deadlock Recovery

---

- Once you've discovered deadlock, what next?
- Terminate one of the tasks to stop circular wait?
  - » Task will likely have to start over from scratch
  - » Which task should you choose?
- Take a resource away from a task?
  - » Again, which task should you choose?
  - » How can you *roll back* the task to the state before it had the coveted resource?
  - » Make sure you don't keep on preempting from the same task: avoid starvation

5/17/2007

cse410-25-deadlock © 2006-07 Perkins, DW Johnson and University of Washington

17

## Ignoring Deadlock

---

- Not a bad policy for operating systems
- The mechanisms outlined previously for handling deadlock may be expensive
  - » if the alternative is to have a forced reboot once a year, that might be acceptable
- However, for thread deadlocks, your users may not be quite so tolerant
  - » “the program only locks up once in a while”

5/17/2007

cse410-25-deadlock © 2006-07 Perkins, DW Johnson and University of Washington

18