

## Instruction-Level Parallelism (ILP)

Fine-grained parallelism

Obtained by:

- instruction overlap in a pipeline
- executing instructions in parallel (later, with multiple instruction issue)

In contrast to:

- **loop-level** parallelism (medium-grained)
- **thread-level** or **task-level** or **process-level** parallelism (coarse-grained)

## Instruction-Level Parallelism (ILP)

Can be exploited when instructions are independent of one another

- two instructions are **independent** if their operands are different
- an example of independent instructions

```
ld R1, 0(R2)
or R7, R3, R8
```

## Dependences

**data dependence:** arises from the flow of values through programs

- consumer instruction gets a value from a producer instruction
- determines the order in which instructions can be executed

<code>ld R1, 32(R3)</code>
<code>add R3, R1, R8</code>

**name dependence:** instructions use the same register but no flow of data between them

- anti-dependence
- output dependence

<code>ld R1, 32(R3)</code>
<code>add R3, R1, R8</code>
<code>ld R1, 16(R3)</code>

## Dependences

**control** dependence

- arises from the flow of control
- instructions after a branch depend on the value of the branch's condition variable

```
    beqz R2, target
    ld r1, 0(r3)
target: add r1, ...
```

## Instruction-Level Parallelism (ILP)

ILP is important for executing instructions in parallel and hiding latencies

- each thread (program) has very little ILP
- dependences inhibit ILP
- tons of techniques to increase it

## Pipelining

Implementation technique (but it is considered part of the architecture)

- overlaps execution of different instructions
- execute all steps in the execution cycle simultaneously, but on different instructions

Exploits ILP by executing several instructions “in parallel”

Goal is to increase instruction throughput

$$\text{optimal speedup} = \frac{T_{\text{without pipe}}}{T_{\text{with pipe}}} = \frac{i \times n}{i + n - 1} \approx \# \text{ of pipe stages}$$

## Pipelining

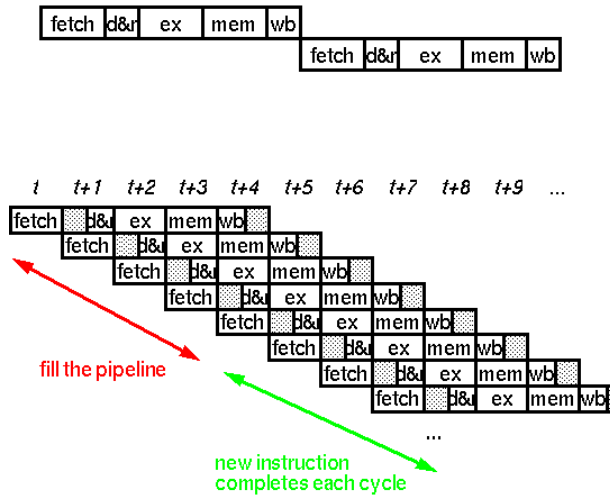

Spring 2013

7

## Pipelining

### Not that simple!

- pipeline hazards (structural, data, control)
  - place a "soft limit" on the number of stages
- increase instruction latency (a little)
  - write & read pipeline registers for data that is computed in a stage
  - all stages are the same length which is determined by the longest stage
    - stage length determines clock cycle time
  - time for clock & control lines to reach all stages

IBM Stretch (1961): the first general-purpose pipelined computer

Spring 2013

CSE 471 Review of Pipelines

8

## Structural Hazards

**Cause:** instructions in different stages want to use the same resource in the same cycle  
e.g., 4 FP instructions ready to execute & only 2 FP units

**Solutions:**

- more hardware (eliminate the hazard)
- stall (so still execute correct programs)
  - less hardware, lower cost
  - only for big hardware components

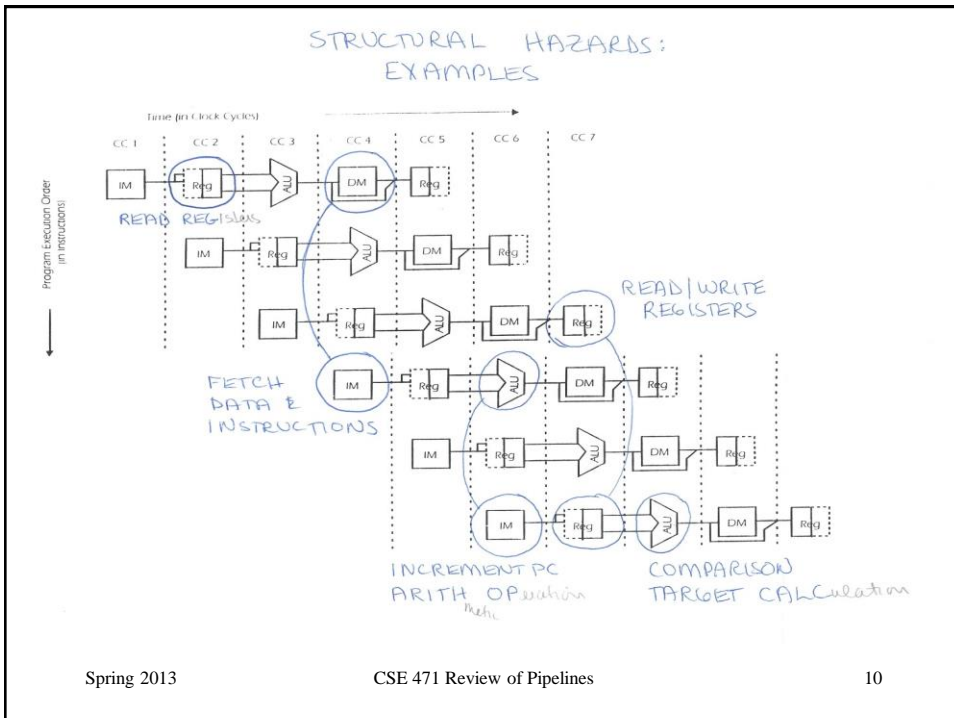

## Data Hazards

### Cause:

- an instruction early in the pipeline needs the result produced by an instruction farther down the pipeline before it is written to a register
- would not have occurred if the implementation was not pipelined

### Types

RAW (data), WAR (name: anti-dependence), WAW (name: output)

### HW solutions

- forwarding hardware (eliminate the hazard)
- stall via pipelined interlocks if can't forward

### Compiler solution

- code scheduling (for loads)

Spring 2013

CSE 471 Review of Pipelines

11

## Dependencies vs. Hazards

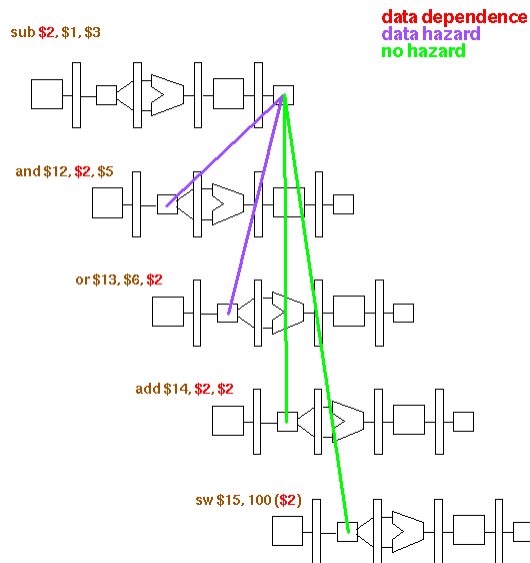

Spring 2013

12

## Forwarding Example

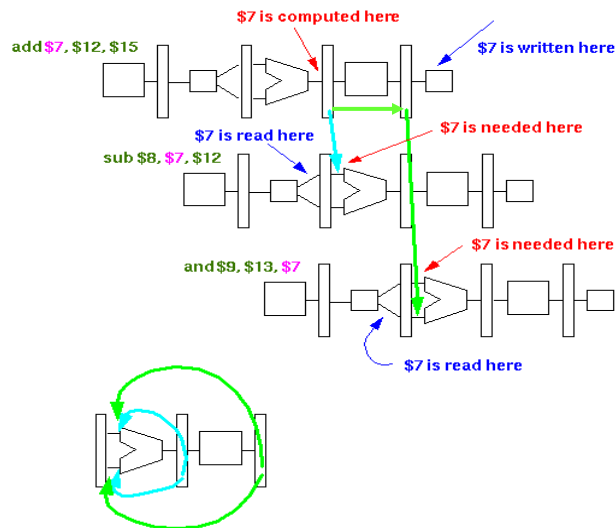

Spring 201

13

## Forwarding

**Forwarding** (also called **bypassing**):

- output of one stage (the result in that stage's pipeline register) is bused (bypassed) to the input of a previous stage
- why forwarding is possible
  - results **are computed** 1 or more stages before they are written to a register
    - at the end of the EX stage for computational instructions
    - at the end of MEM for a load
  - results **are used** 1 or more stages after registers are read
- if you forward a result to an ALU input as soon as it has been computed, you can eliminate the hazard or reduce stalling

Spring 2013

CSE 471 Review of Pipelines

14

## Forwarding Implementation

**Forwarding unit** checks to see if values must be forwarded:

- between instructions in ID and EX
  - compare the R-type **destination register number in EX/MEM** pipeline register to each **source register number in ID/EX**
- between instructions in ID and MEM
  - compare the R-type **destination register number in MEM/WB** to each **source register number in ID/EX**

If a match, then forward the appropriate result values to an ALU source

- bus a value from **EX/MEM** or **MEM/WB** to an ALU source

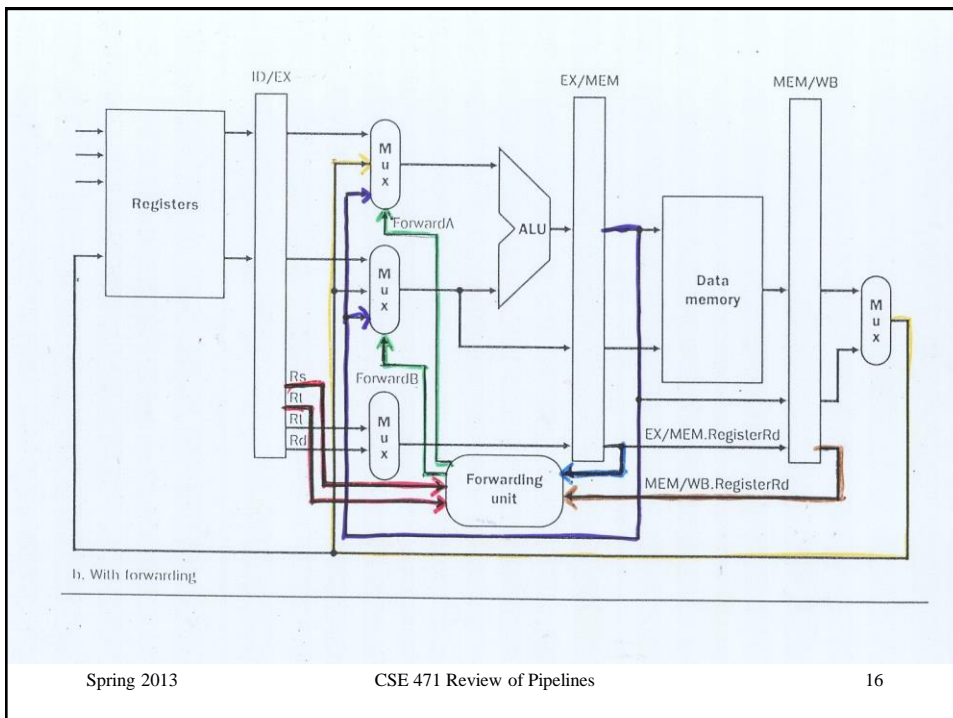



## Forwarding Hardware

Hardware to implement forwarding:

- destination register number in pipeline registers (but need it anyway because we need to know which register to write when storing an ALU or load result)
- source register numbers (probably only one, e.g., `rs` on MIPS R2/3000) is extra)
- a comparator for each source-destination register pair
- **buses to ship data – the BIG cost**
- buses to ship register numbers
- larger ALU MUXes for 2 bypass values

## Loads

### **Loads**

- data hazard caused by a load instruction & an immediate use of the loaded value
- forwarding won't eliminate the hazard -- why?
- 2 solutions used together
  - stall via pipelined interlocks
  - compiler schedules independent instructions into the **load delay slot**  
(This is a reason that pipelines are part of the architecture: the pipeline structure is exposed to the compiler.)

## Loads

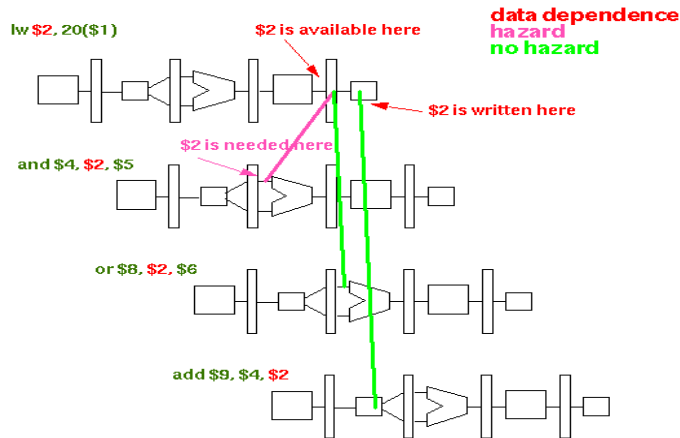

## Implementing Pipelined Interlocks

Detecting a stall situation

**Hazard detection unit** stalls the use after a load

- is the instruction in EX a load?
- does the destination register number of the load = either source register number in the next instruction?
  - compare the load write register number in ID/EX to each read register number in IF/ID

⇒ if yes, stall the pipe 1 cycle

## Implementing Pipelined Interlocks

How stalling is implemented:

- **nullify the instruction in the ID stage**, the one that consumes the loaded value
  - change EX, MEM, WB control signals in ID/EX pipeline register to 0
  - the instruction in the ID stage will have no **side effects** as it passes down the pipeline
- **repeat the instructions in ID & IF stages**
  - disable writing the IF/ID pipeline register – the load consumer instruction will be decoded & its registers read again
  - disable writing the PC – the same instruction will be fetched again

Spring 2013

CSE 471 Review of Pipelines

21

## Loads

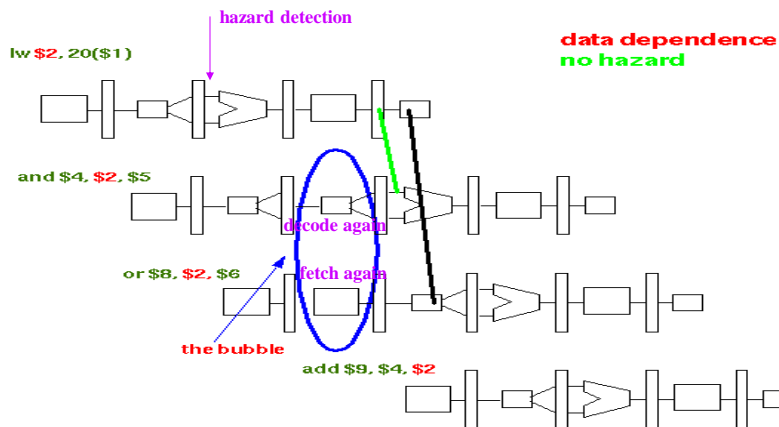

Spring 2013

CSE 471 Review of Pipelines

22

## Implementing Pipelined Interlocks

Hardware to implement stalling:

- rt register number in ID/EX pipeline register (but need it anyway because we need to know what register to write when storing load data)
- both source register numbers in IF/ID pipeline register (already there)
- a comparator for each source-destination register pair
- buses to ship register numbers
- write enable/disable for PC
- write enable/disable for the IF/ID pipeline register
- a MUX to the ID/EX pipeline register (+ 0s)

**Trivial amount of hardware & needed for cache misses anyway**

## Control Hazards

**Cause:** condition & target determined after next fetch

### **Early HW solutions**

- stall
- assume an outcome & flush pipeline if wrong
- move branch resolution hardware forward in the pipeline

### **Compiler solutions**

- code scheduling
- static branch prediction

### **Today's HW solutions**

- *dynamic branch prediction*