

Approximate Inference in Bayes Nets

Sampling based methods

Mausam

(Based on slides by Jack Breese and
Daphne Koller)

Bayes Nets is a generative model

- We can easily generate samples from the distribution represented by the Bayes net
 - Generate one variable at a time in topological order

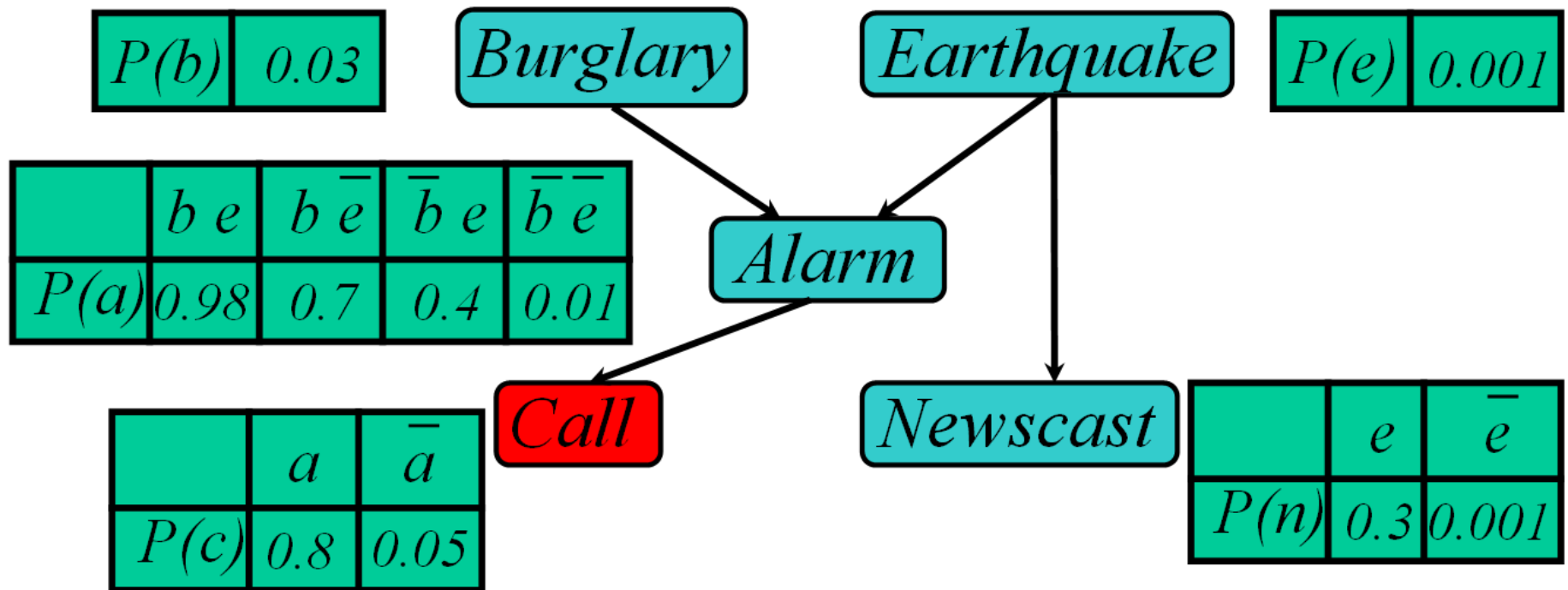

Stochastic simulation $P(B|C)$

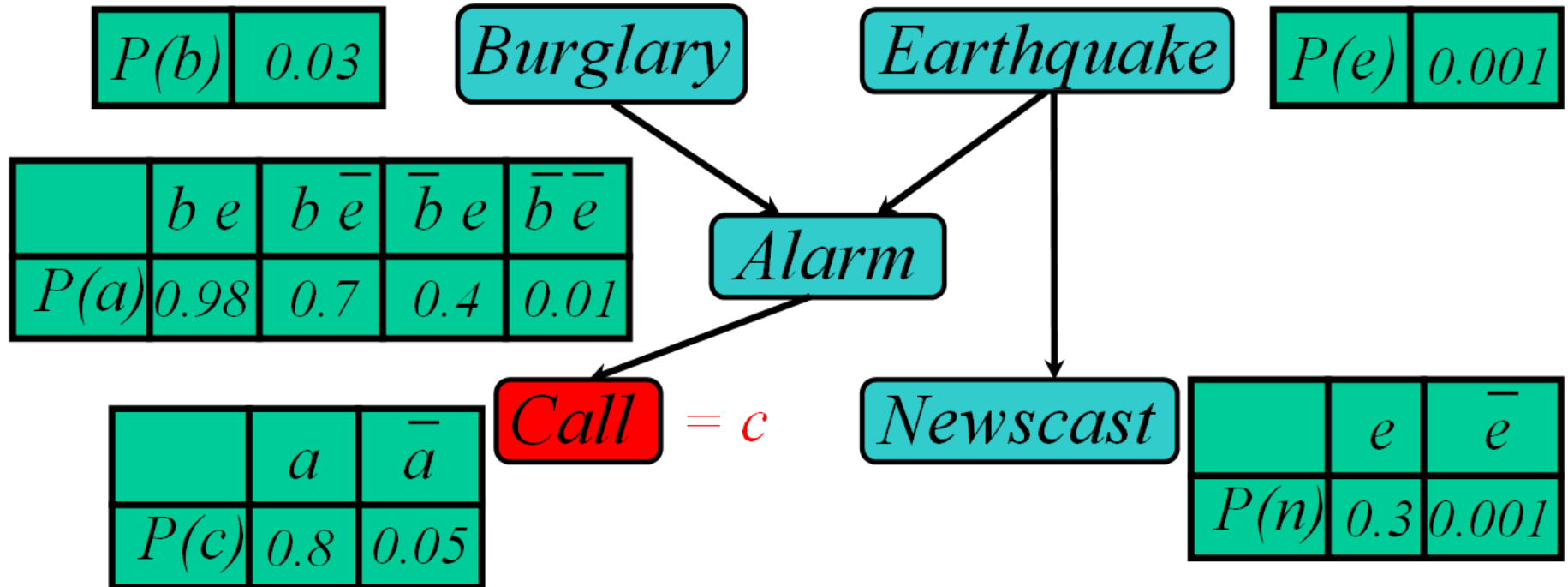

Stochastic simulation $P(B|C)$

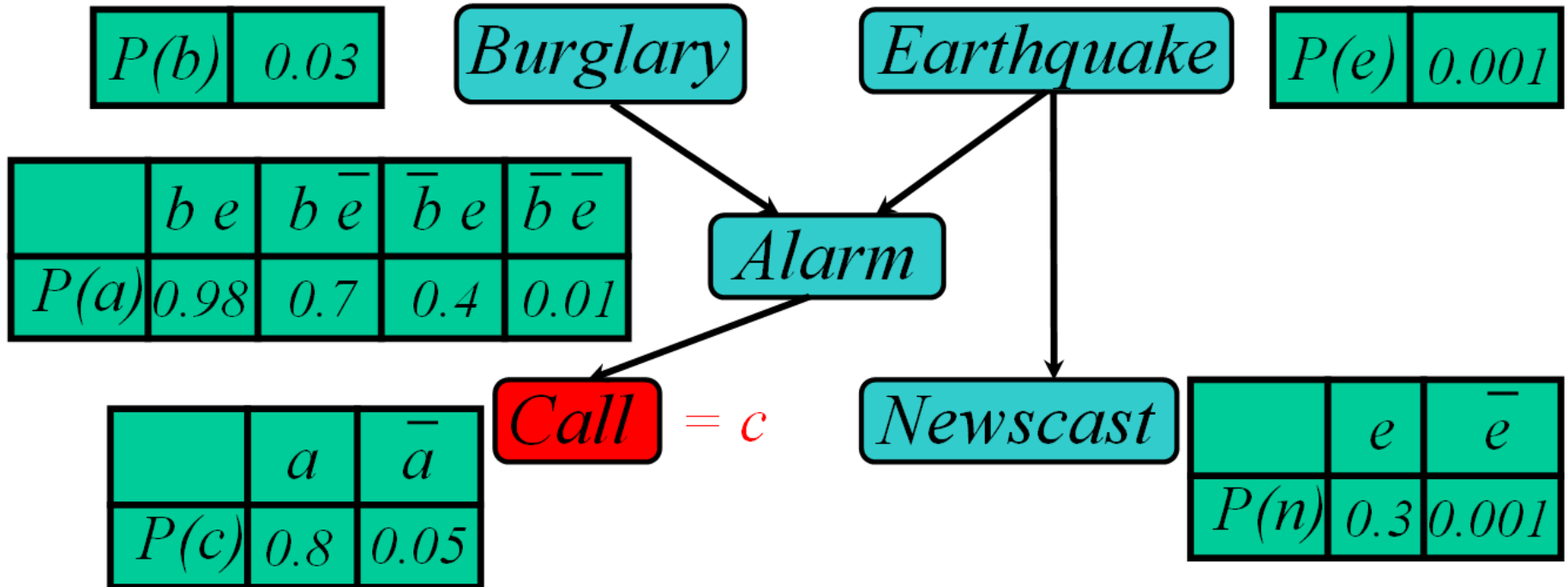

Samples:

B	E	A	C	N

Stochastic simulation $P(B|C)$

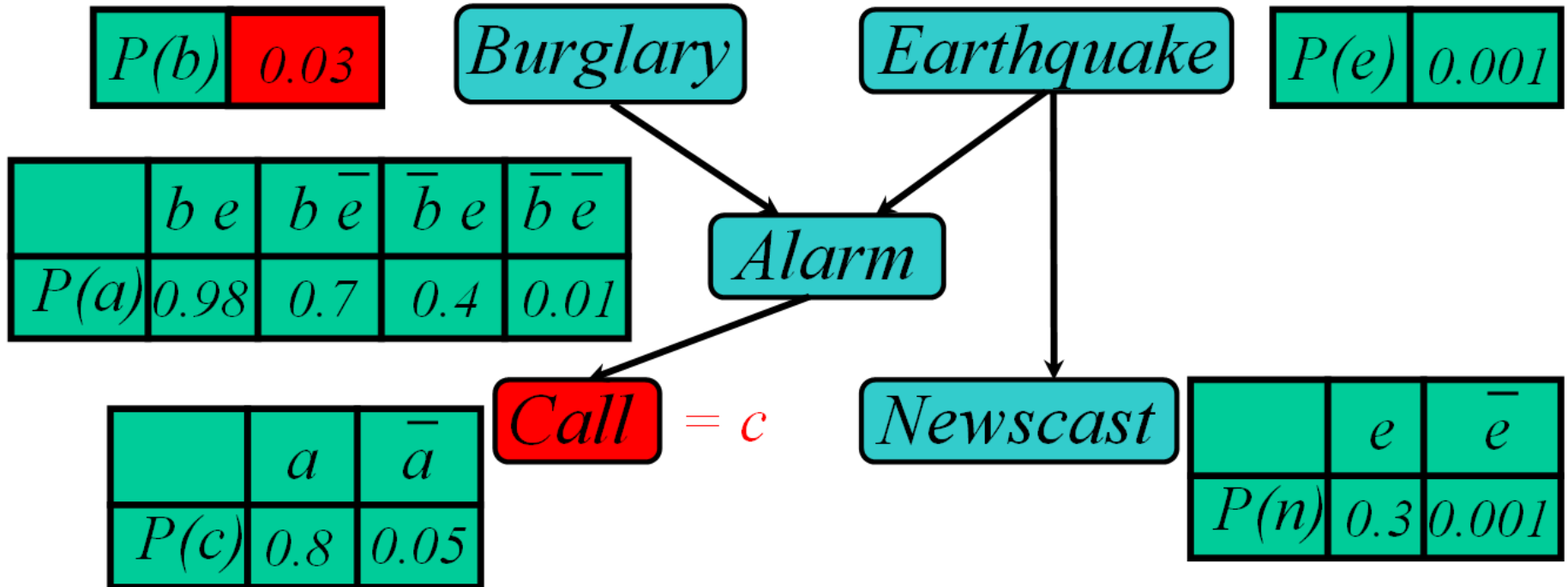

Samples:

B	E	A	C	N

Stochastic simulation $P(B|C)$

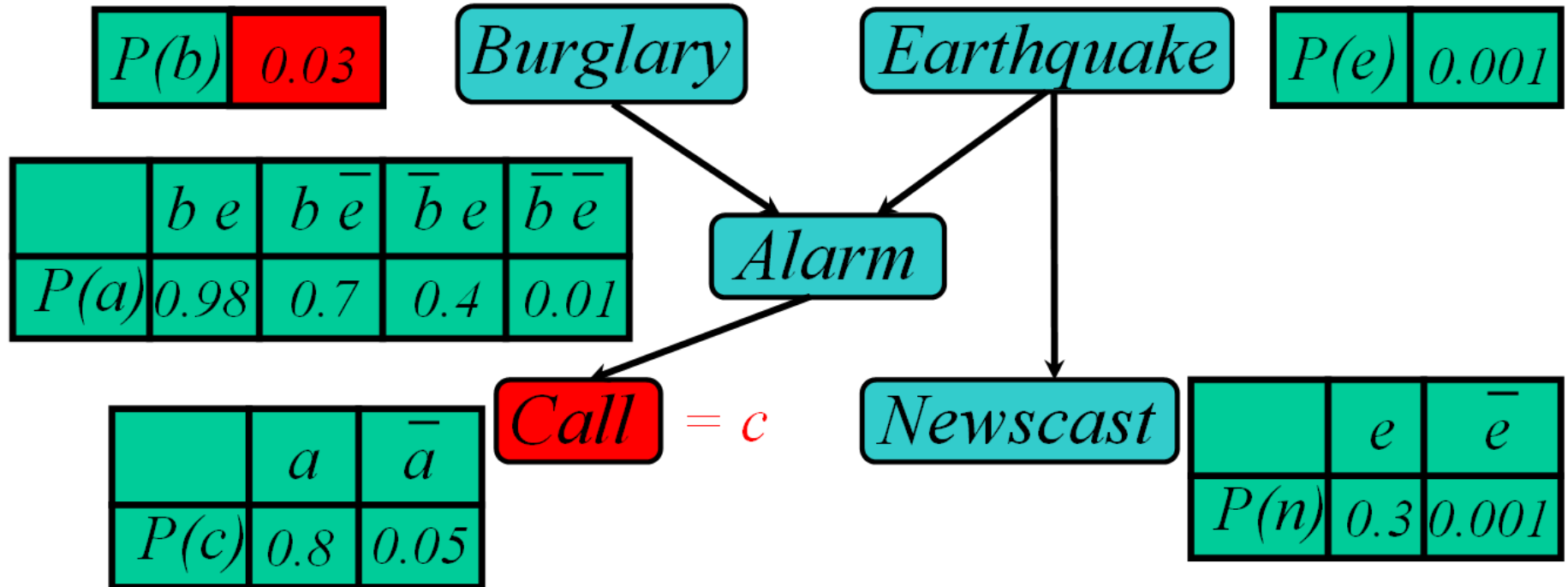

Samples:

B	E	A	C	N
\bar{b}				

Stochastic simulation $P(B|C)$

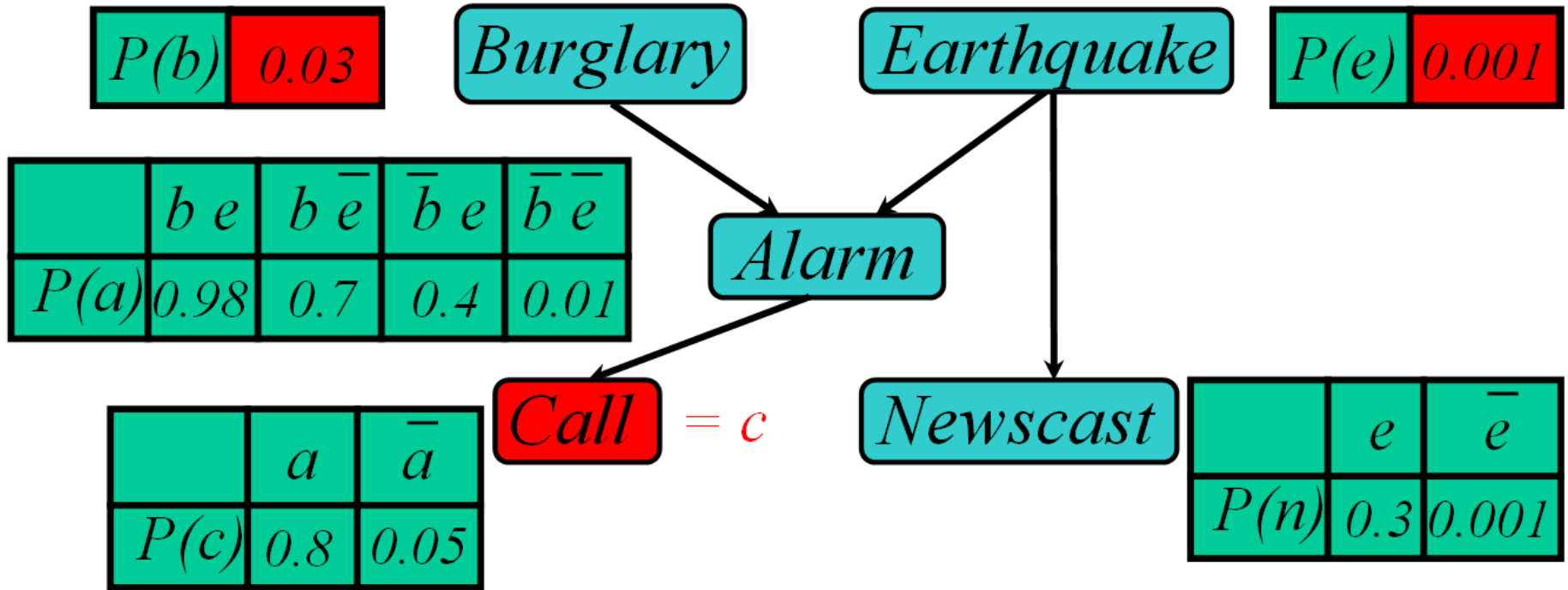

Samples:

B	E	A	C	N
\bar{b}				

Stochastic simulation $P(B|C)$

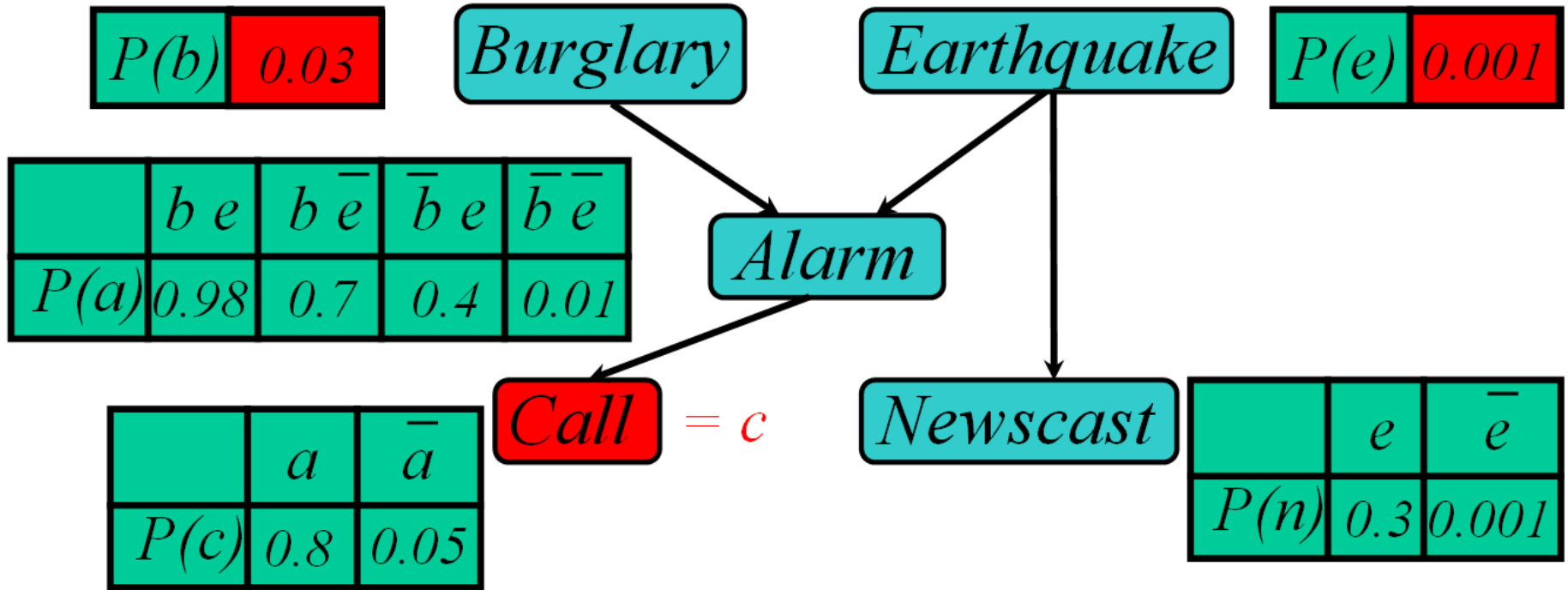

Samples:

B	E	A	C	N
\bar{b}	e			

Stochastic simulation $P(B|C)$

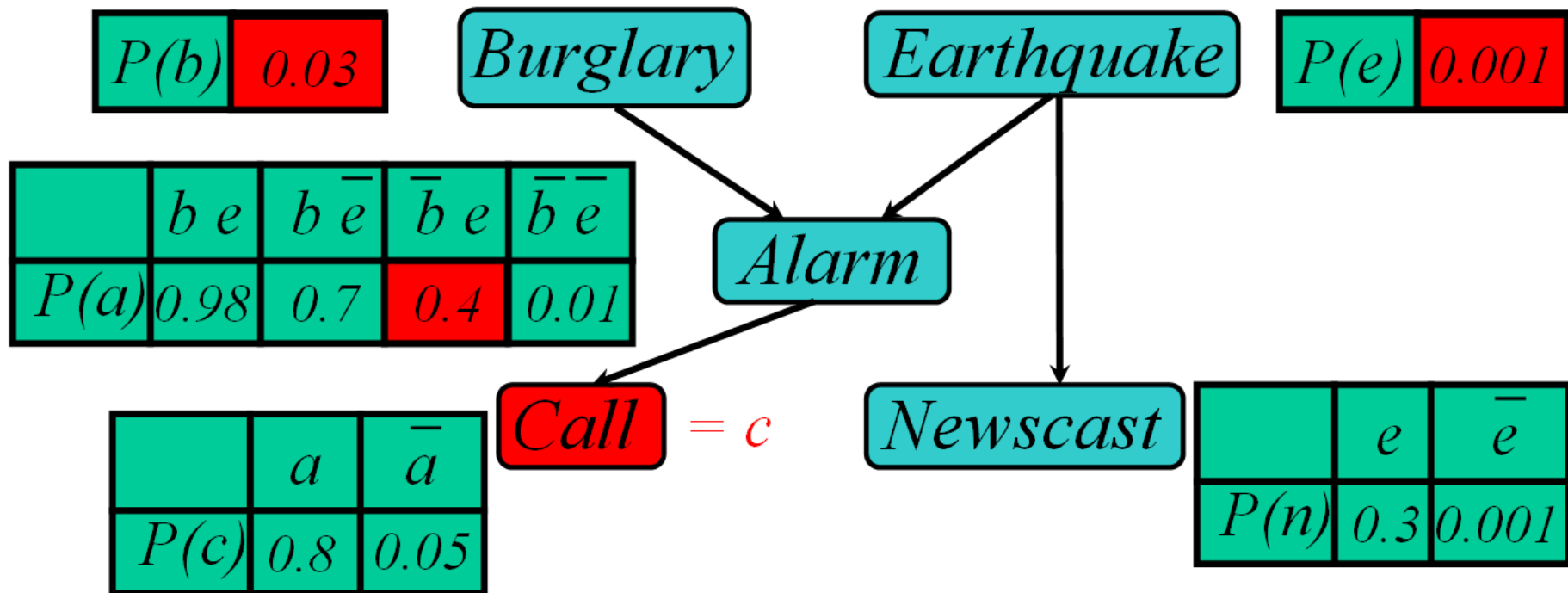

Samples:

B	E	A	C	N
\bar{b}	e			

Stochastic simulation $P(B|C)$

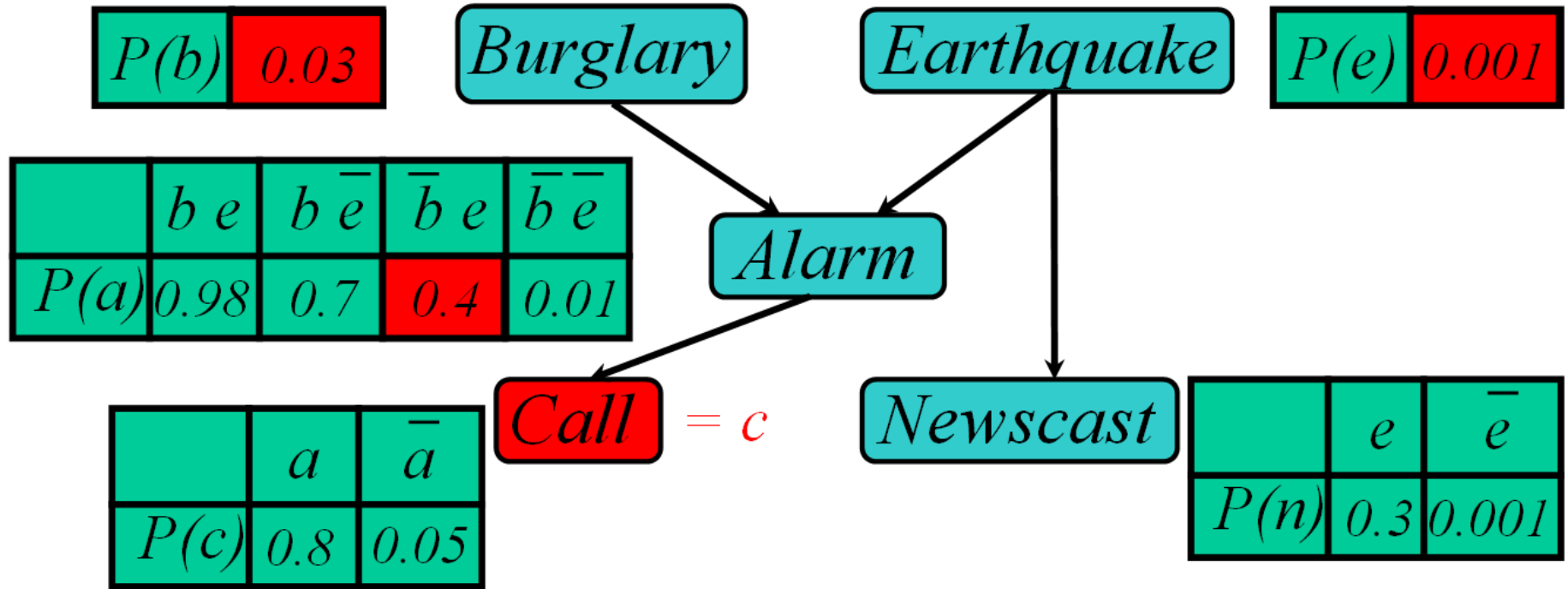

Samples:

B	E	A	C	N
\bar{b}	e	a		

Stochastic simulation $P(B|C)$

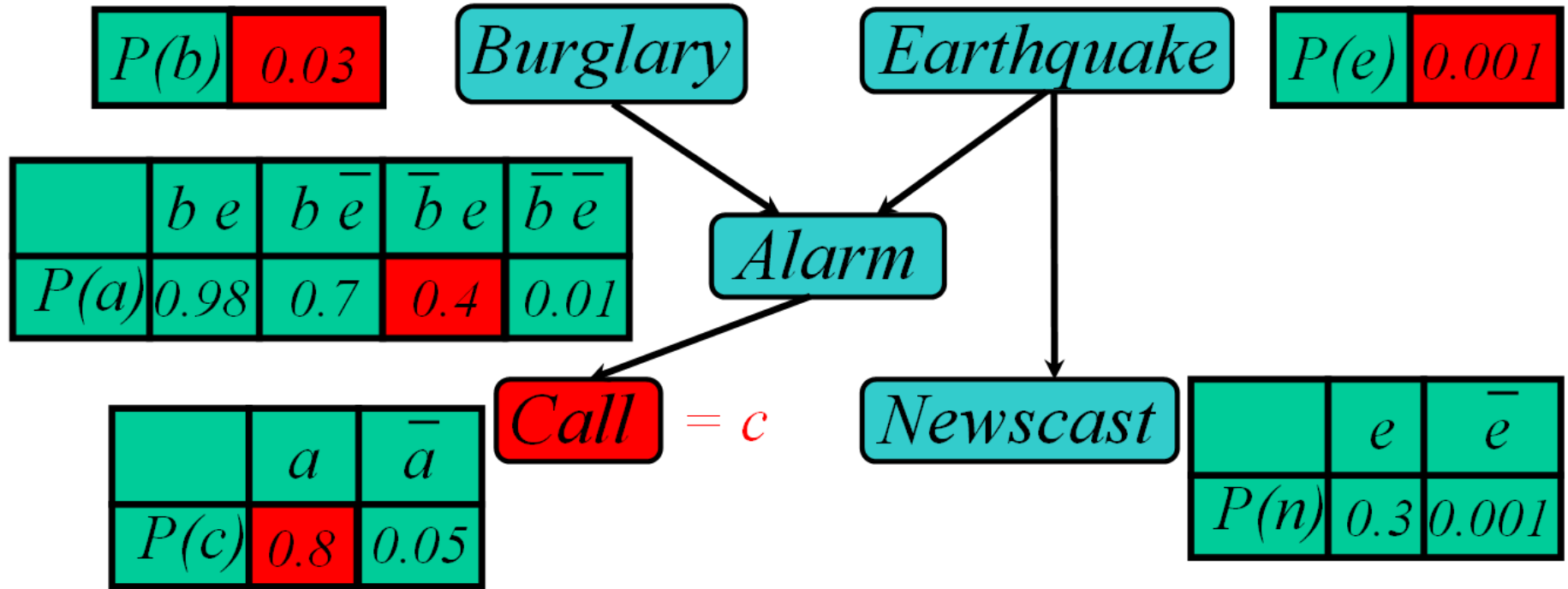

Samples:

B	E	A	C	N
\bar{b}	e	a		

Stochastic simulation $P(B|C)$

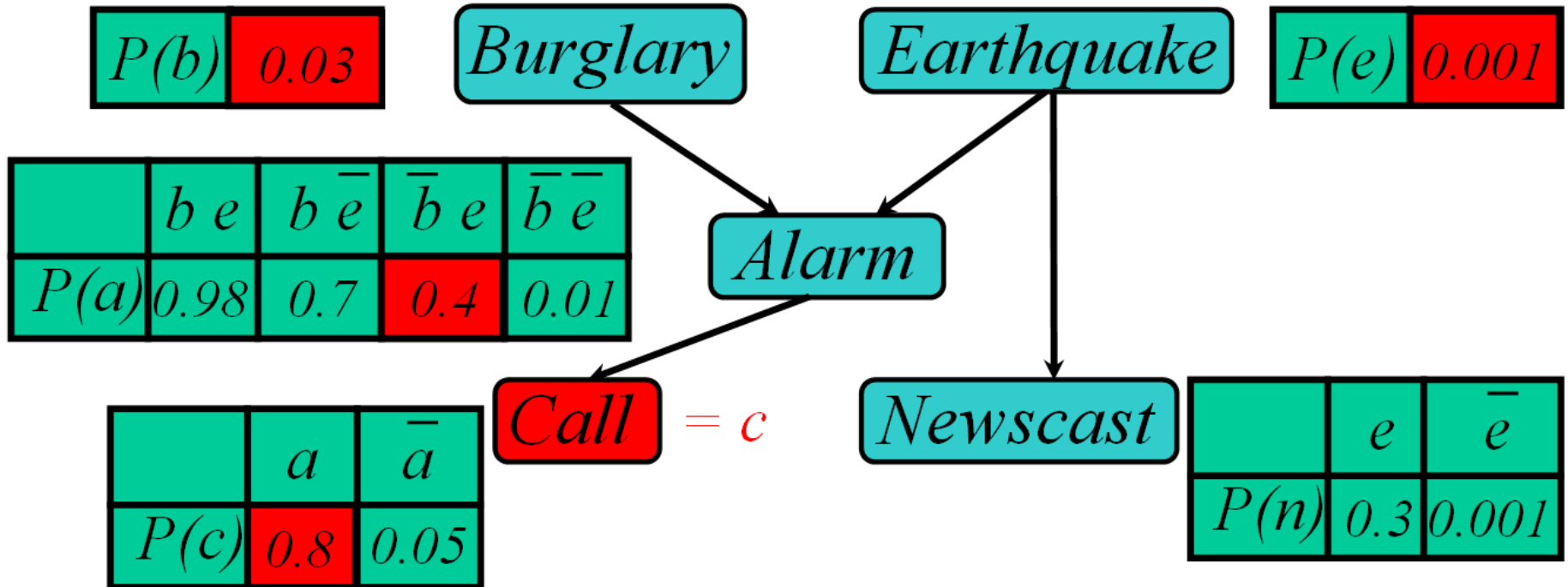

Samples:

B	E	A	C	N
\bar{b}	e	a	c	

Stochastic simulation $P(B|C)$

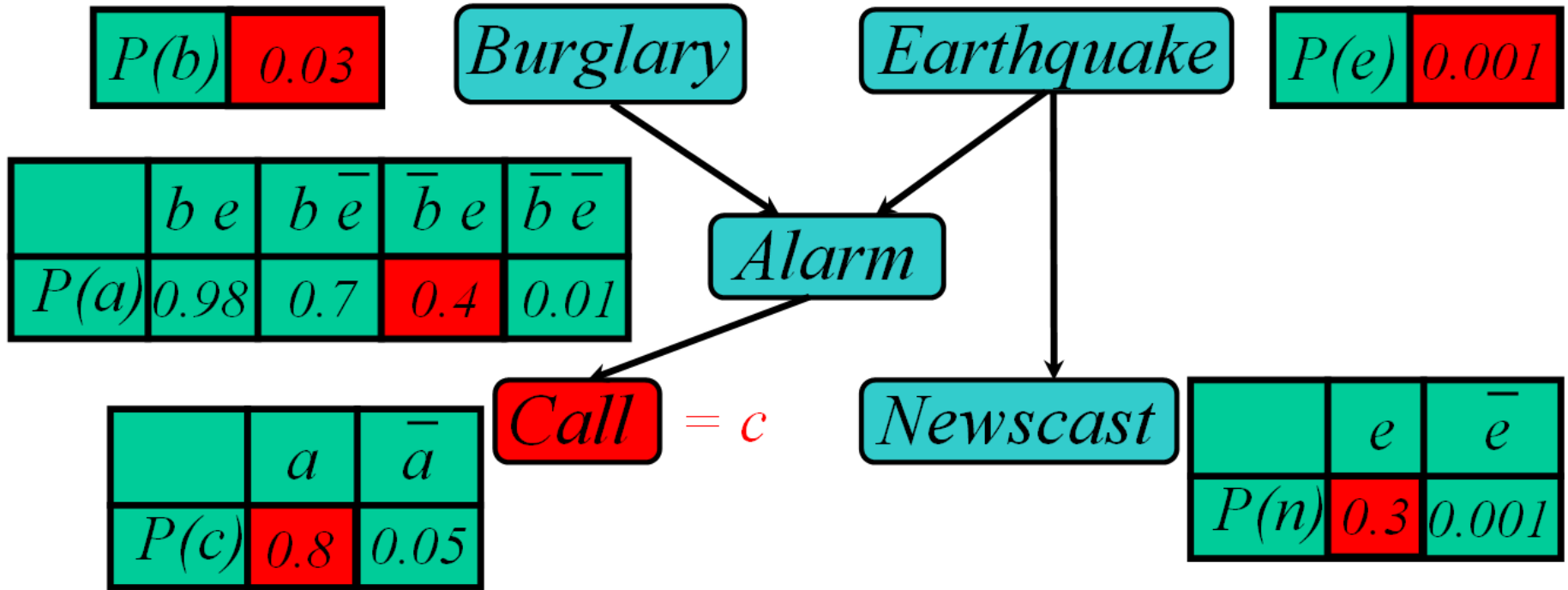

Samples:

B	E	A	C	N
\bar{b}	e	a	c	

Stochastic simulation $P(B|C)$

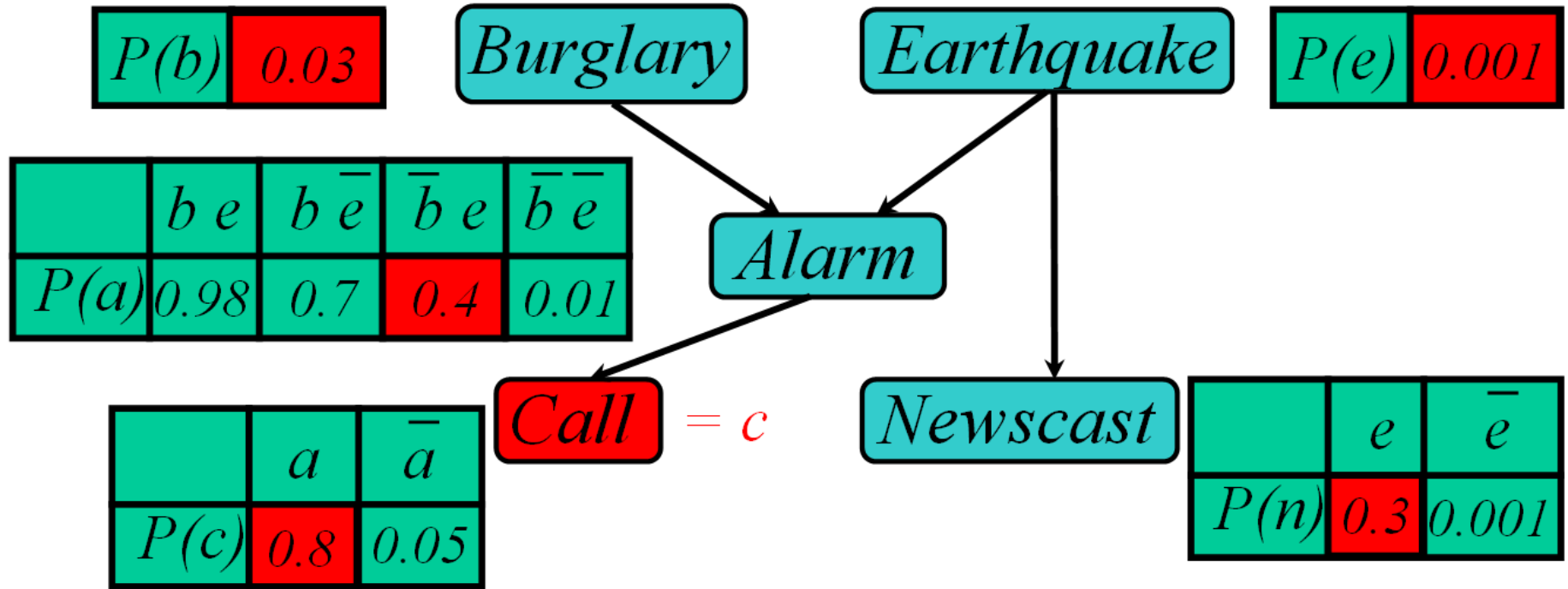

Samples:

B	E	A	C	N
\bar{b}	e	a	c	\bar{n}

Stochastic simulation $P(B|C)$

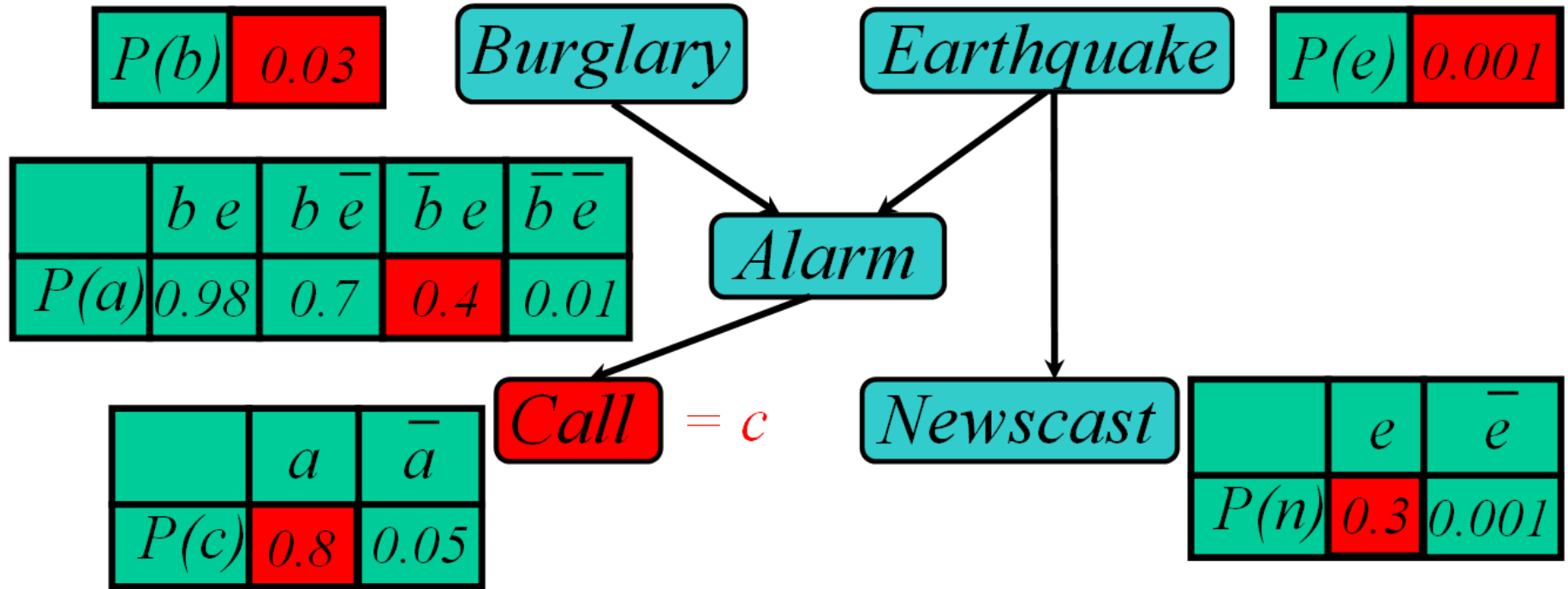

Samples:

B	E	A	C	N
\bar{b}	e	a	c	\bar{n}
b	\bar{e}	a	\bar{c}	n

Stochastic simulation $P(B|C)$

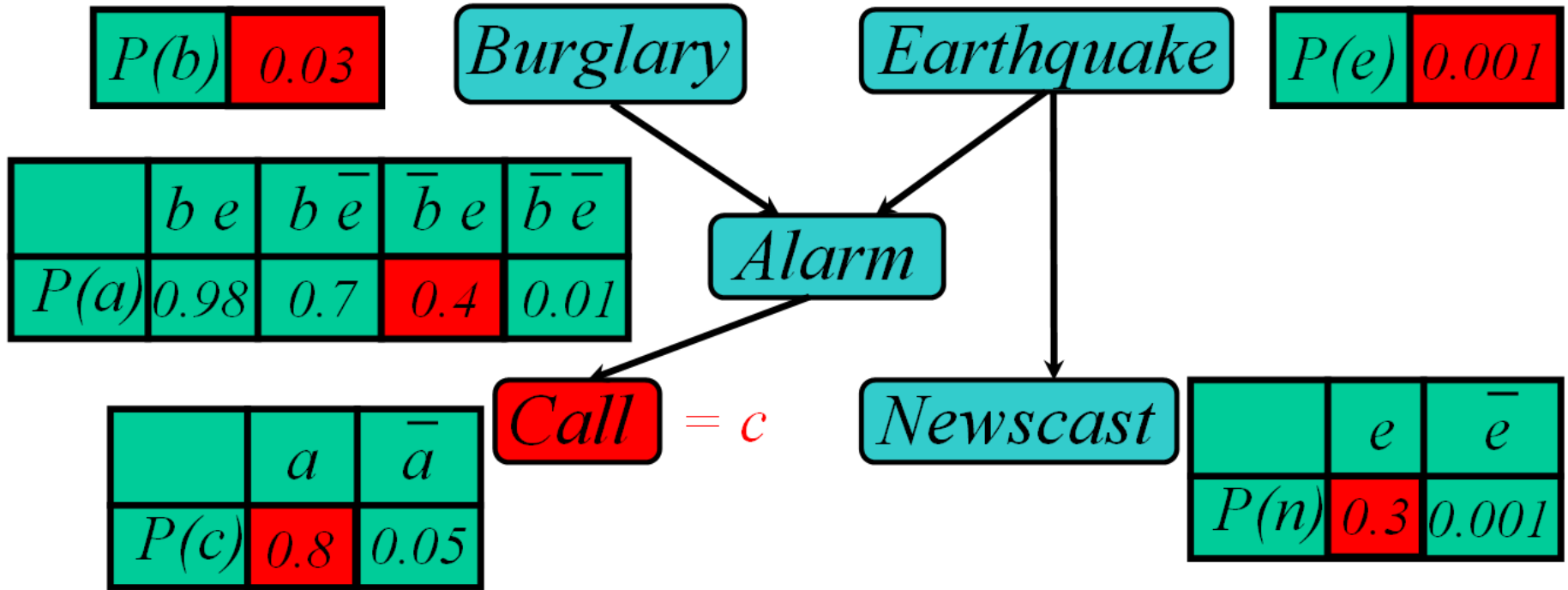

Samples:

B	E	A	C	N
\bar{b}	e	a	c	\bar{n}
b	\bar{e}	\bar{a}	\bar{c}	n

Stochastic simulation $P(B|C)$

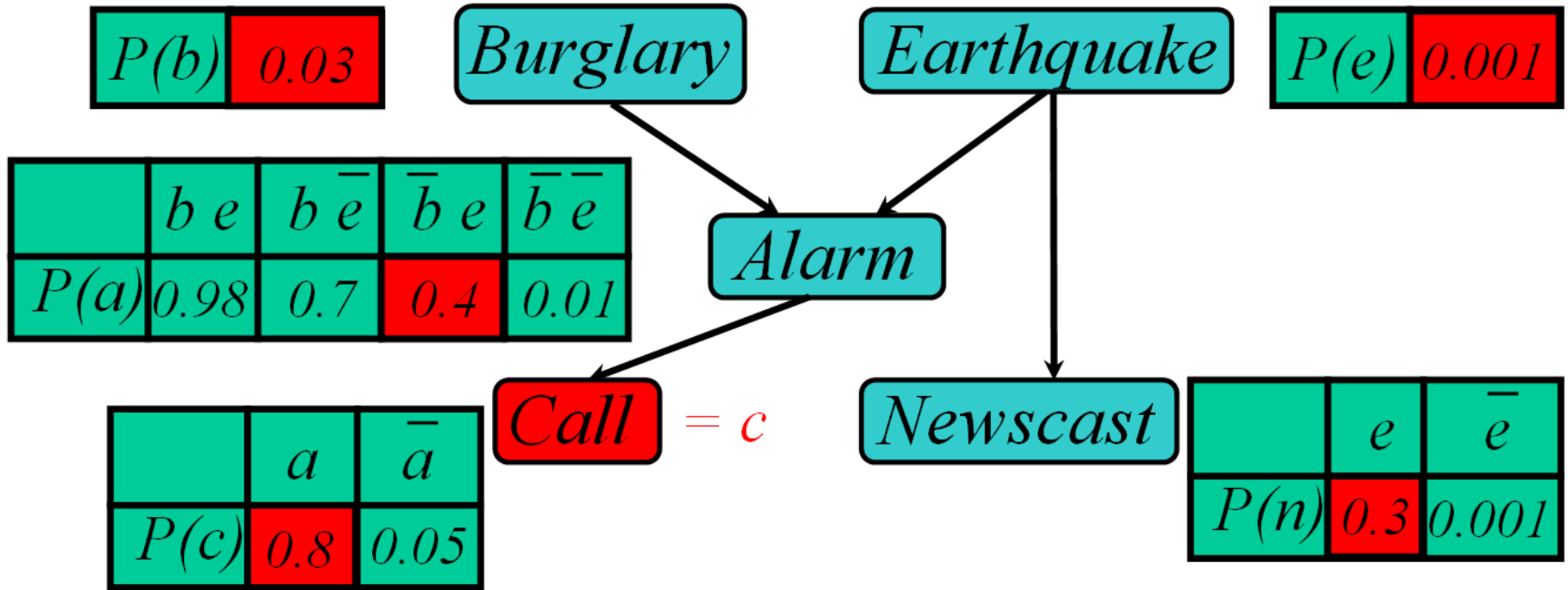

Samples:

B	E	A	C	N
\bar{b}	e	a	c	\bar{n}
b	\bar{e}	\bar{a}	\bar{c}	n
	\vdots			

Stochastic simulation $P(B|C)$

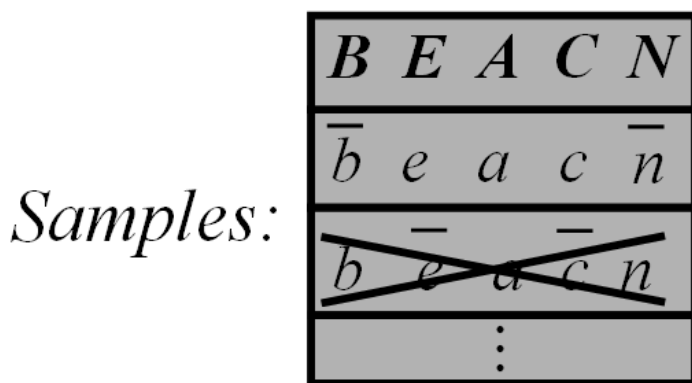
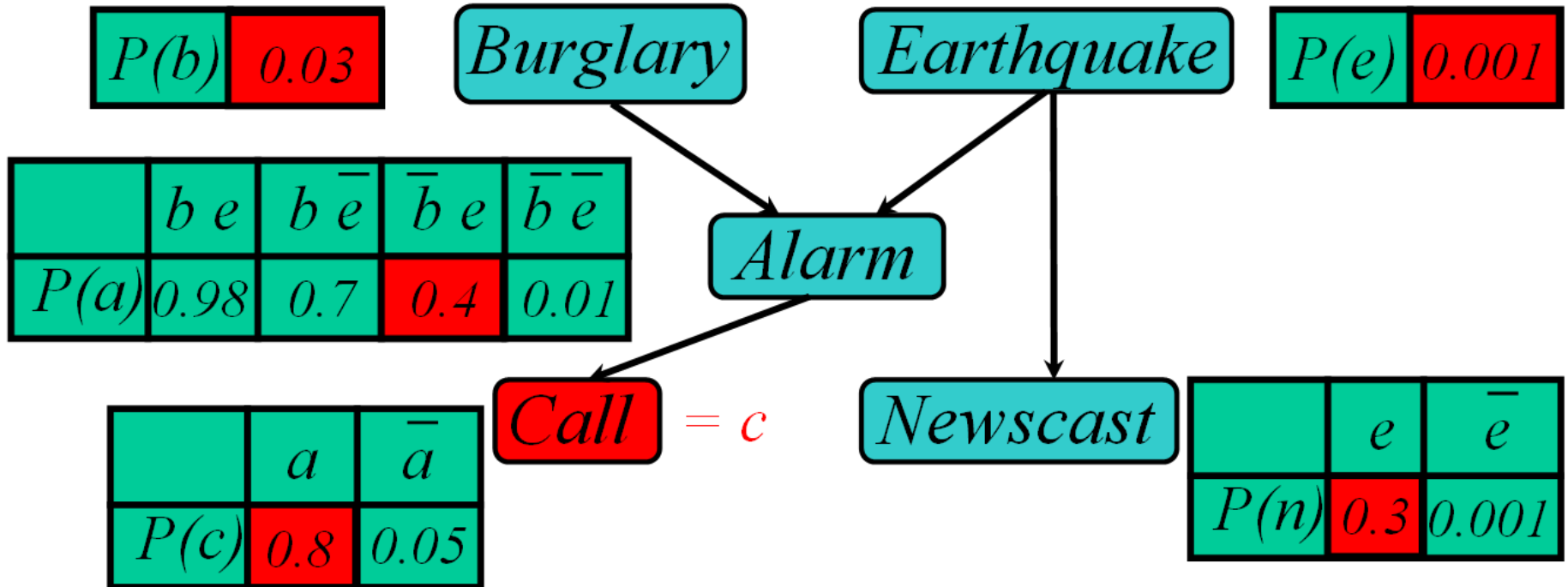

$$P(b|c) \sim \frac{\text{\# of live samples with } B=b}{\text{total \# of live samples}}$$

Rejection Sampling

- Sample from the prior
 - reject if do not match the evidence
- Returns consistent posterior estimates
- Hopelessly expensive if $P(e)$ is small
 - $P(e)$ drops off exponentially if no. of evidence vars

Likelihood Weighting

- Idea:
 - fix evidence variables
 - sample only non-evidence variables
 - weight each sample by the likelihood of evidence

Likelihood weighting $P(B|C)$

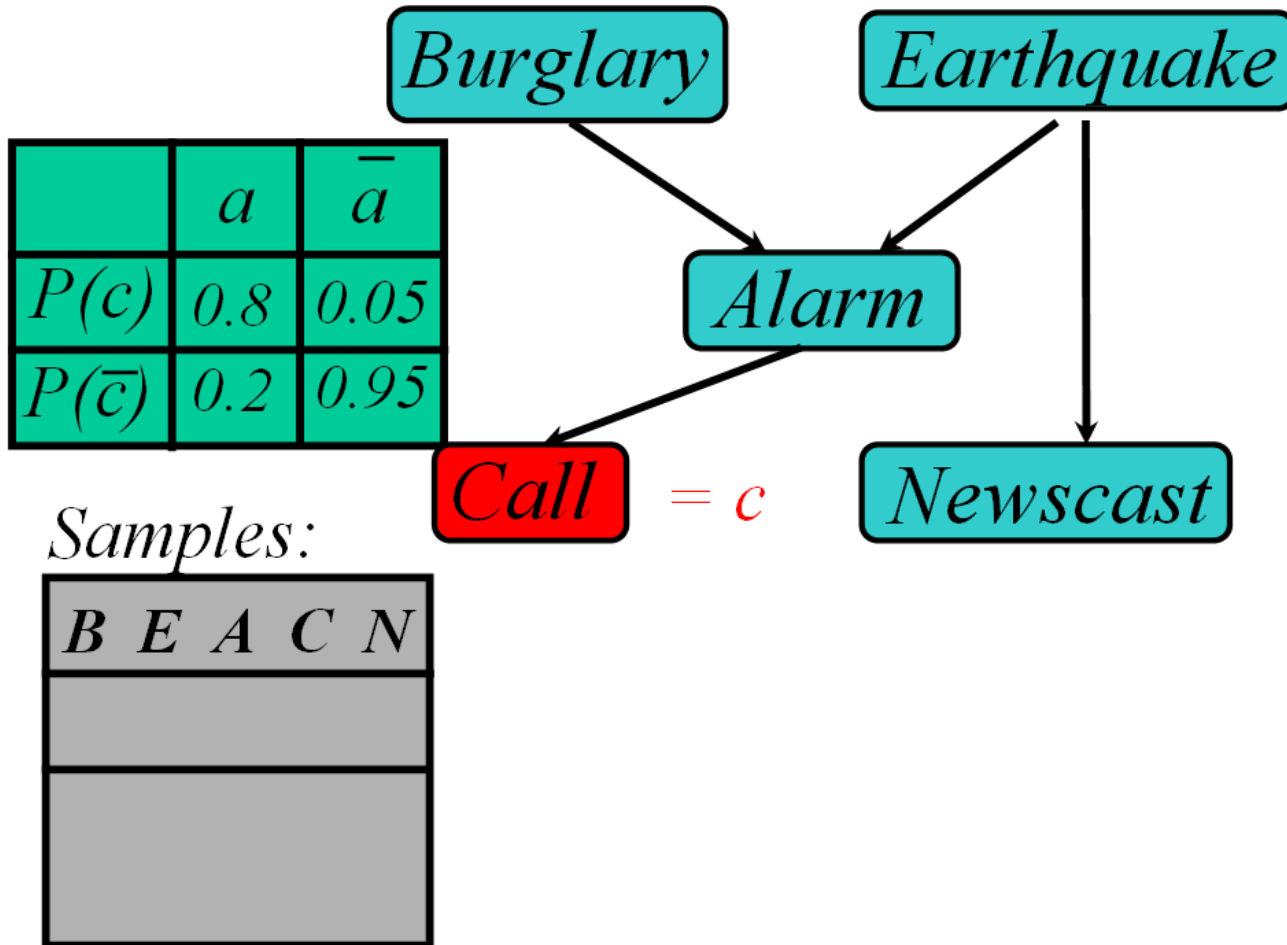

Likelihood weighting $P(B|C)$

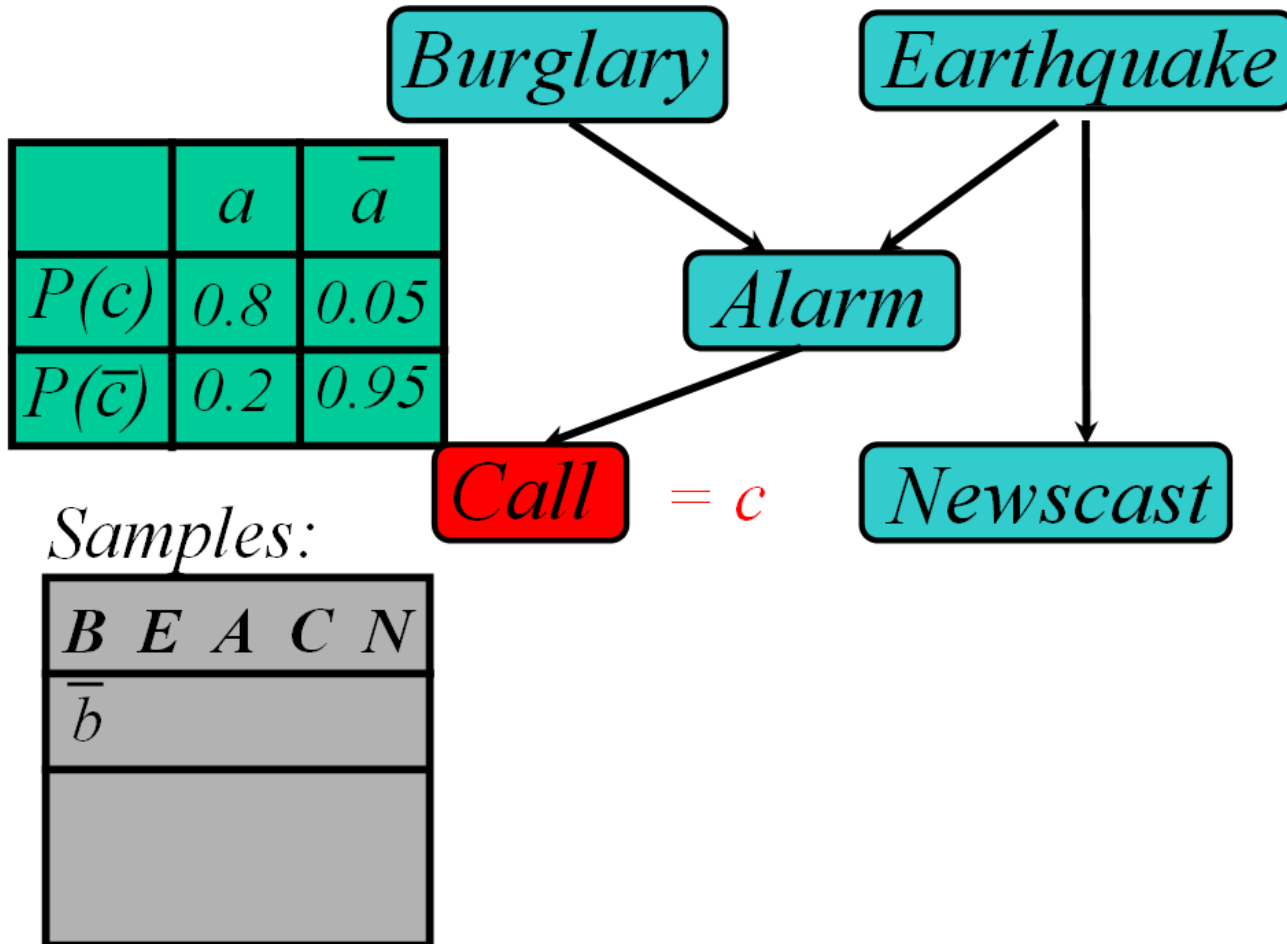

Likelihood weighting $P(B|C)$

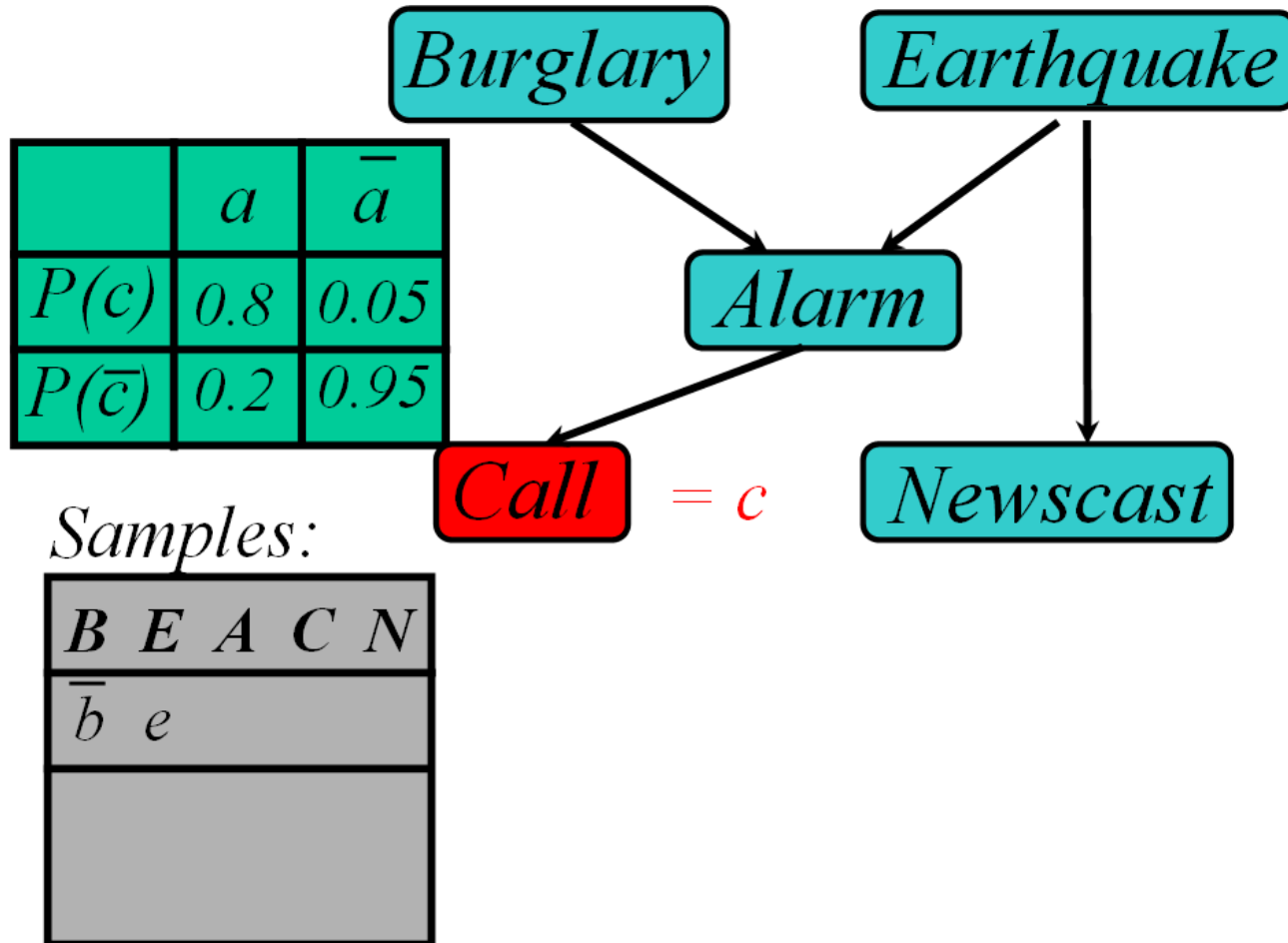

Likelihood weighting $P(B|C)$

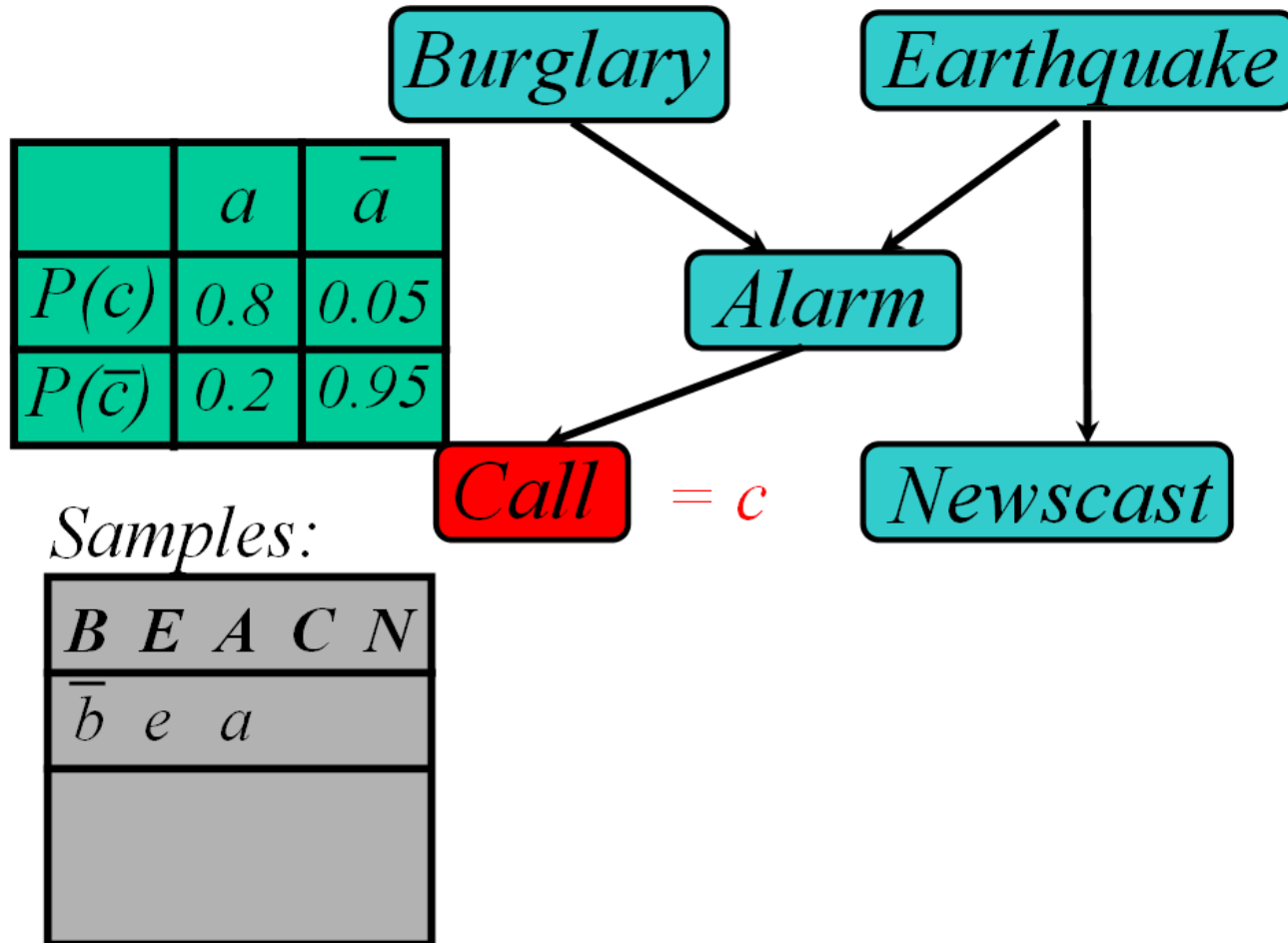

Likelihood weighting $P(B|C)$

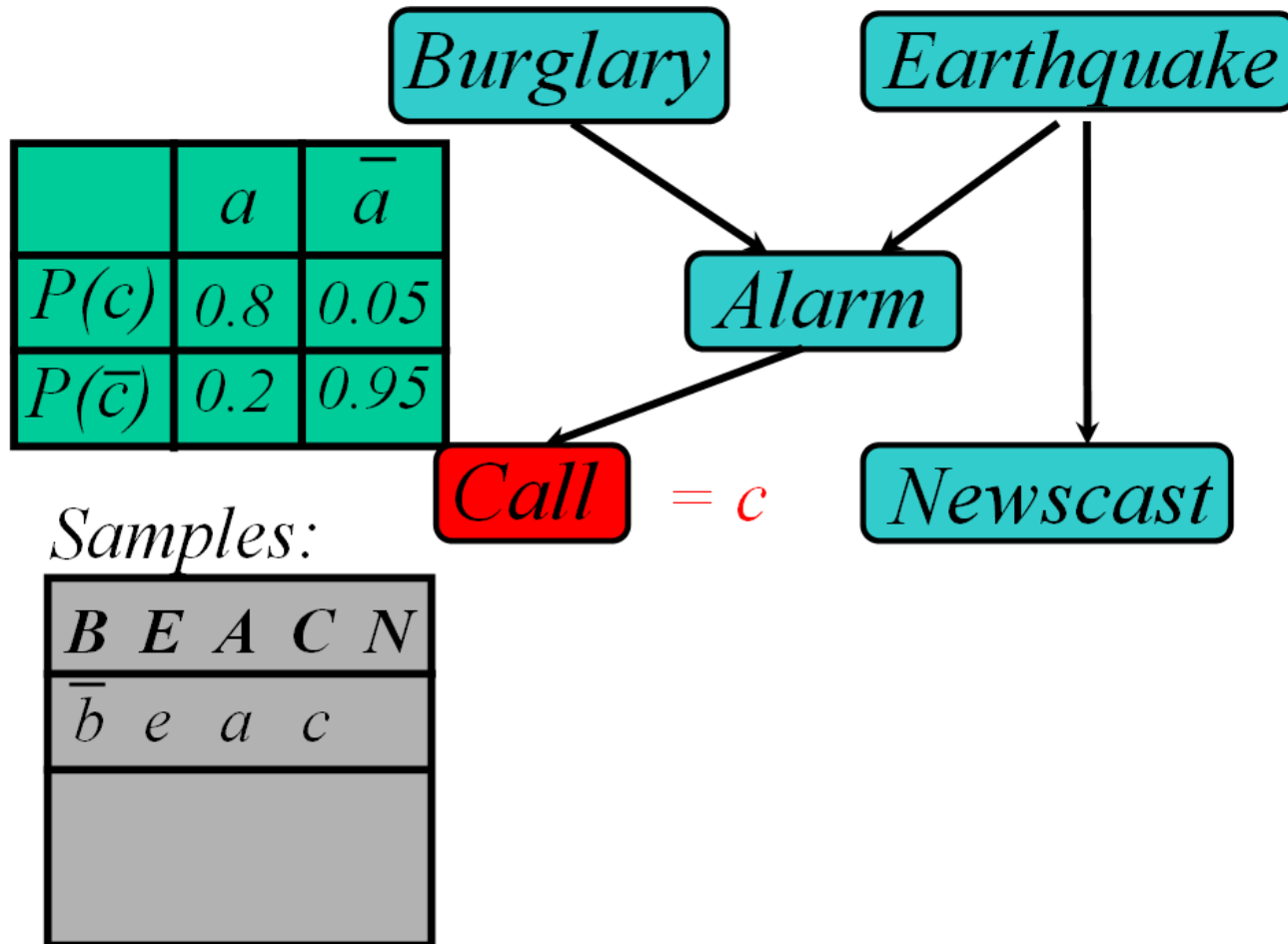

Likelihood weighting $P(B|C)$

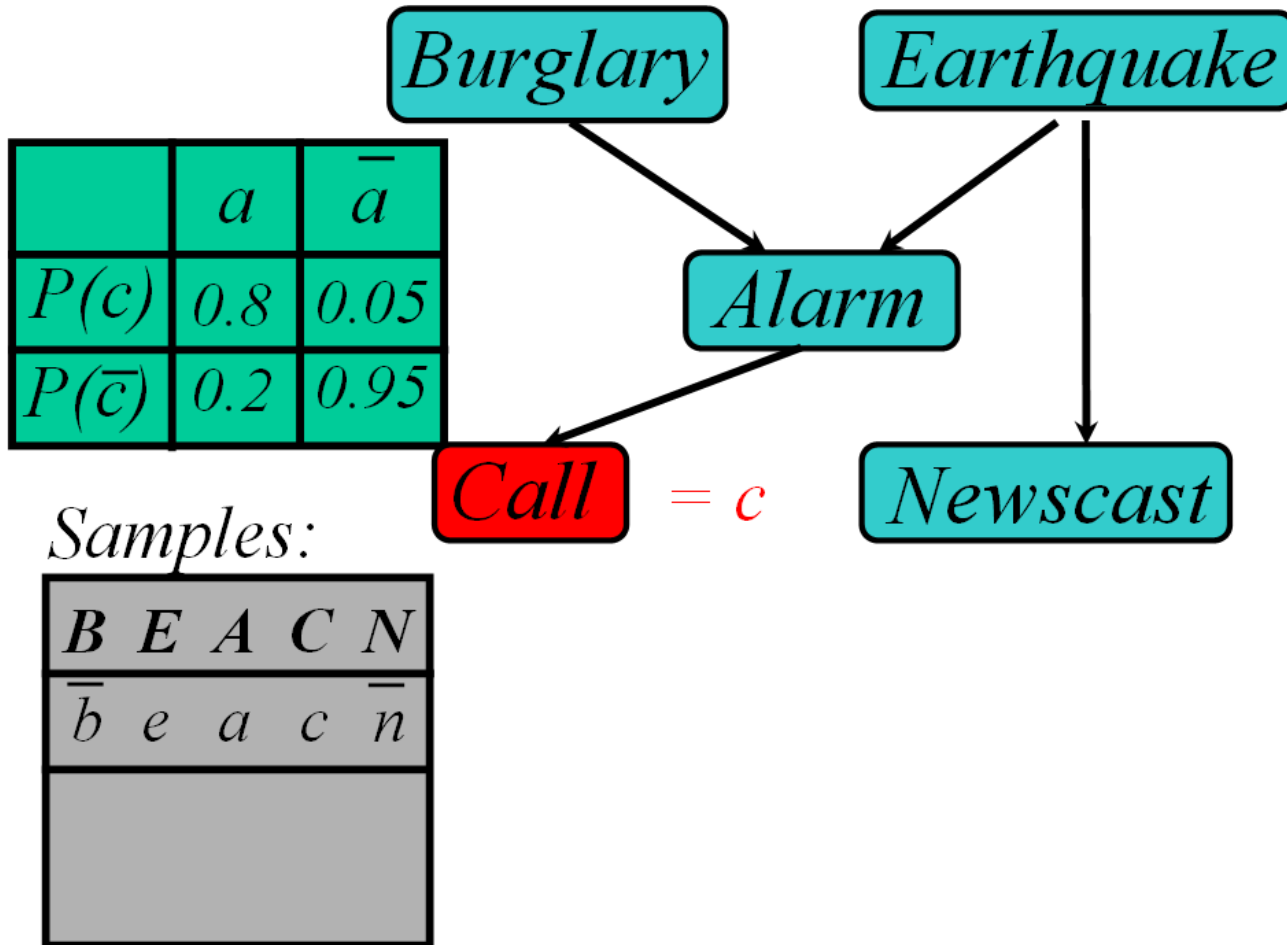

Likelihood weighting $P(B|C)$

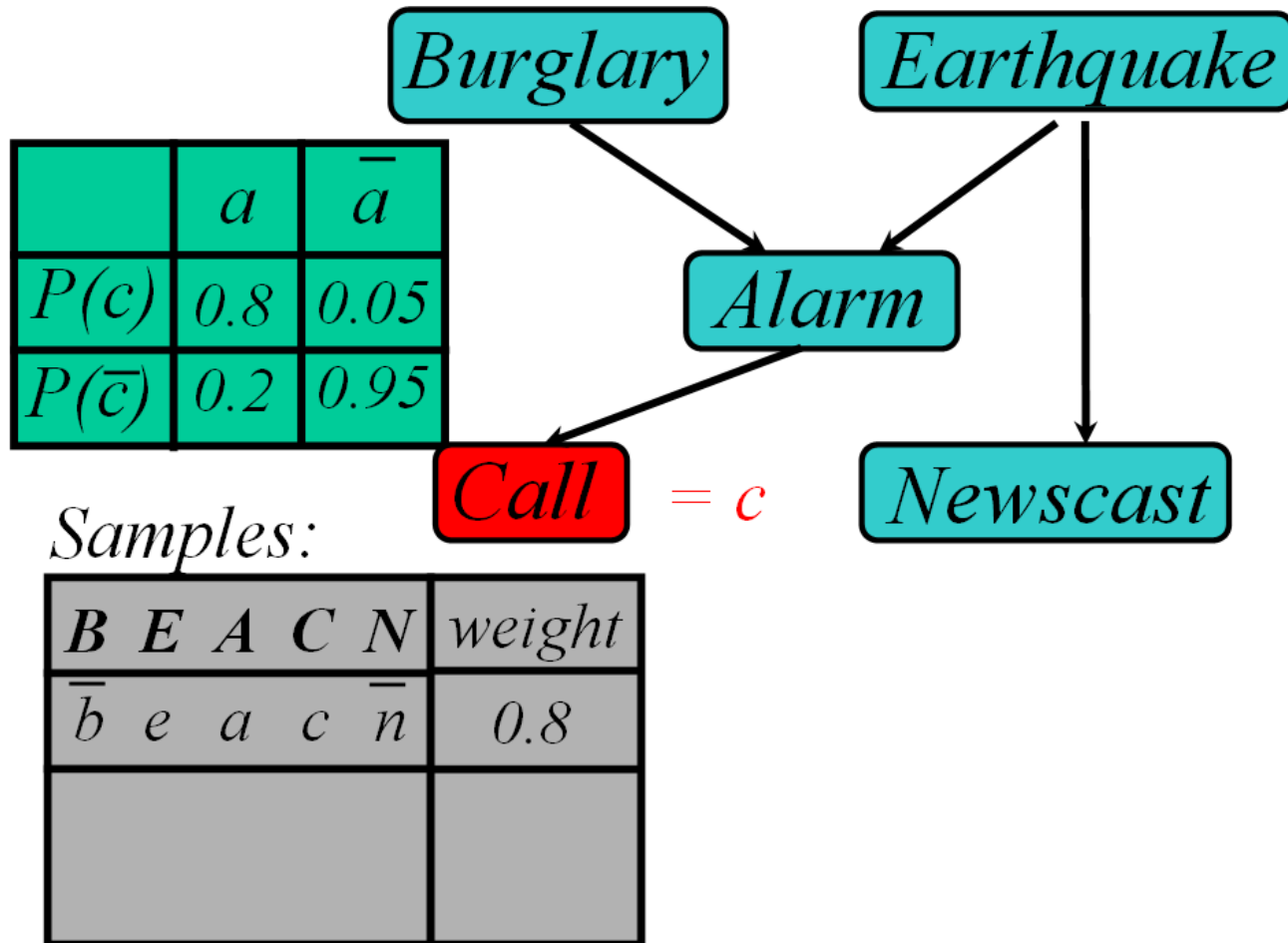

Likelihood weighting $P(B|C)$

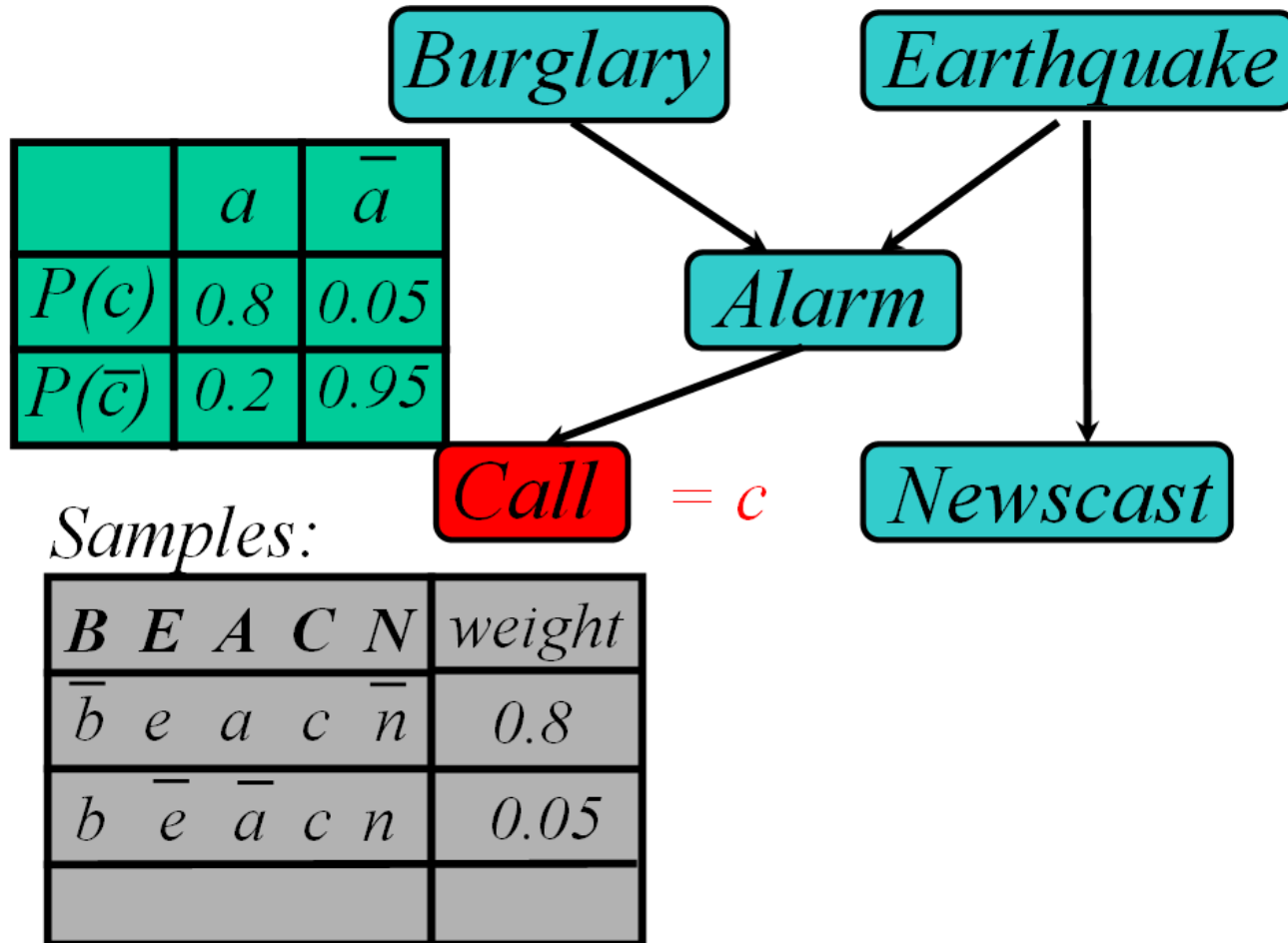

Likelihood weighting $P(B|C)$

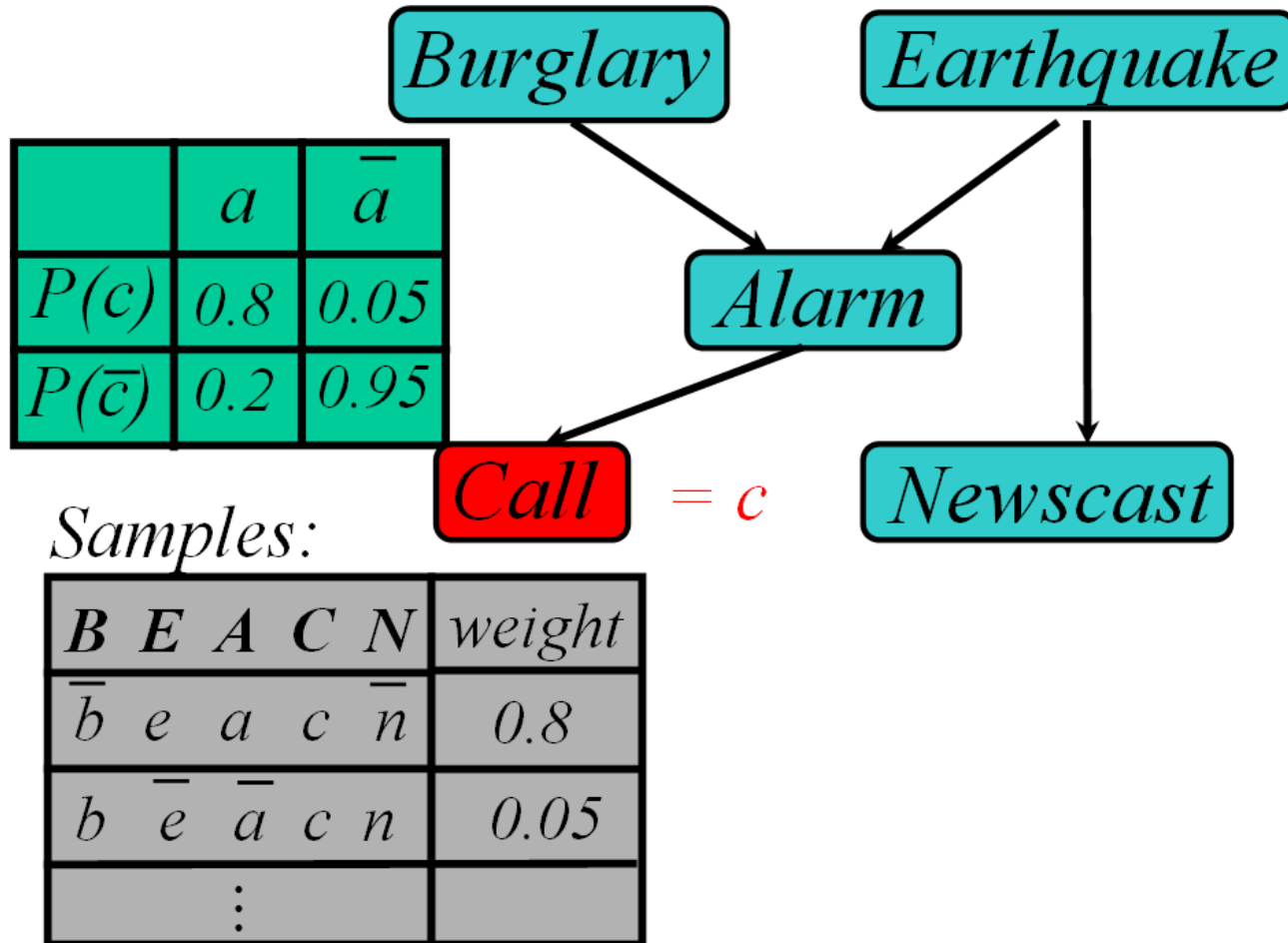

Likelihood weighting $P(B|C)$

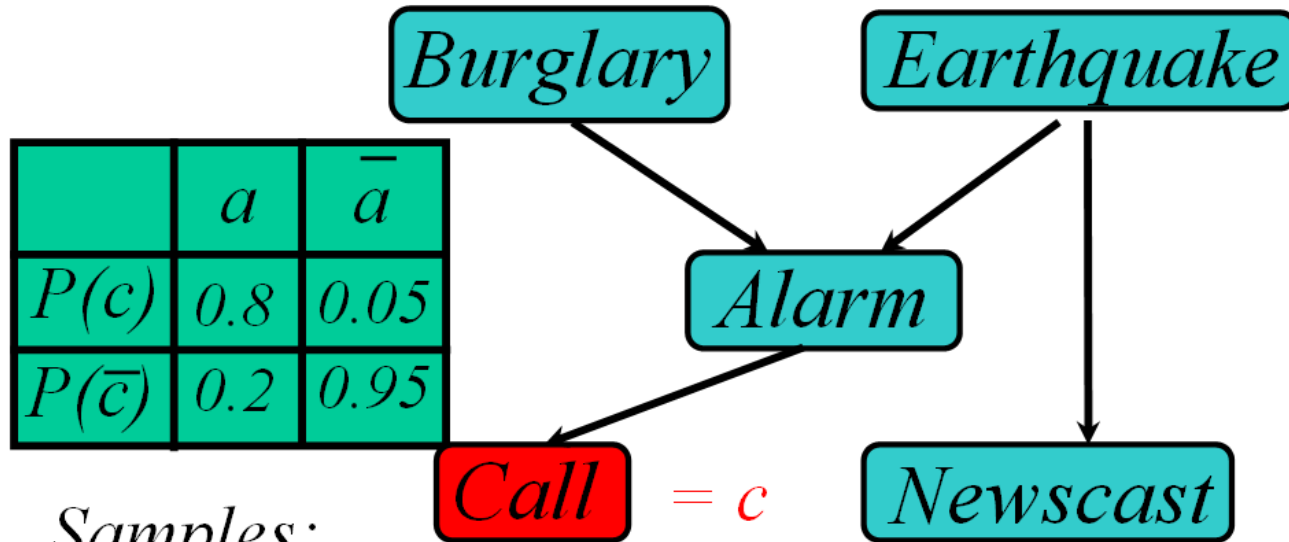

	a	\bar{a}
$P(c)$	0.8	0.05
$P(\bar{c})$	0.2	0.95

Samples:

B	E	A	C	N	weight
\bar{b}	e	a	c	\bar{n}	0.8
b	\bar{e}	\bar{a}	c	n	0.05
	\vdots				

$$P(b|c) = \frac{\text{weight of samples with } B=b}{\text{total weight of samples}}$$

Likelihood Weighting

- **Sampling probability:** $S(z,e) = \prod_i P(z_i | \text{Parents}(Z_i))$
 - Neither prior nor posterior
- **Wt for a sample $\langle z,e \rangle$:** $w(z,e) = \prod_i P(e_i | \text{Parents}(E_i))$
- **Weighted Sampling probability** $S(z,e)w(z,e)$
 - $= \prod_i P(z_i | \text{Parents}(Z_i)) \prod_i P(e_i | \text{Parents}(E_i))$
 - $= P^i(z,e)$
- **→ returns consistent estimates**
- **performance degrades w/ many evidence vars**
 - but a few samples have nearly all the total weight
 - late occurring evidence vars do not guide sample generation

MCMC with Gibbs Sampling

- Fix the values of observed variables
- Set the values of all non-observed variables randomly
- Perform a random walk through the space of complete variable assignments. On each move:
 1. Pick a variable X
 2. Calculate $\Pr(X=\text{true} \mid \text{all other variables})$
 3. Set X to true with that probability
- Repeat many times. Frequency with which any variable X is true is its posterior probability.
- Converges to true posterior when frequencies stop changing significantly
 - stable distribution, mixing

Markov Blanket Sampling

- How to calculate $\Pr(X=\text{true} \mid \text{all other variables})$?
- Recall: a variable is independent of all others given it's Markov Blanket
 - parents
 - children
 - other parents of children
- So problem becomes calculating $\Pr(X=\text{true} \mid \text{MB}(X))$
 - We solve this sub-problem exactly
 - Fortunately, it is easy to solve

$$P(X) = \alpha P(X \mid \text{Parents}(X)) \prod_{Y \in \text{Children}(X)} P(Y \mid \text{Parents}(Y))$$

Example

$$P(X) = \alpha P(X \mid \text{Parents}(X)) \prod_{Y \in \text{Children}(X)} P(Y \mid \text{Parents}(Y))$$

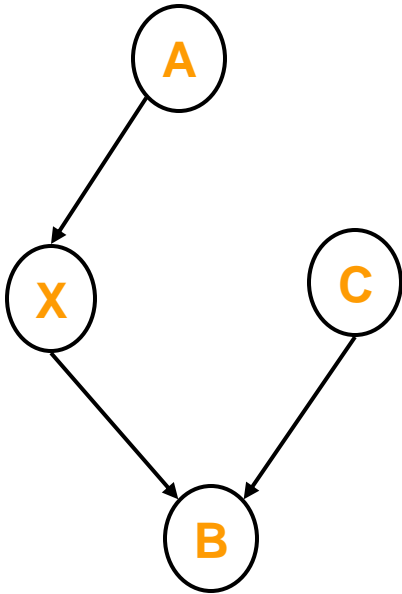

$$\begin{aligned} P(X \mid A, B, C) &= \frac{P(X, A, B, C)}{P(A, B, C)} \\ &= \frac{P(A)P(X \mid A)P(C)P(B \mid X, C)}{P(A, B, C)} \\ &= \left[\frac{P(A)P(C)}{P(A, B, C)} \right] P(X \mid A)P(B \mid X, C) \\ &= \alpha P(X \mid A)P(B \mid X, C) \end{aligned}$$

Example

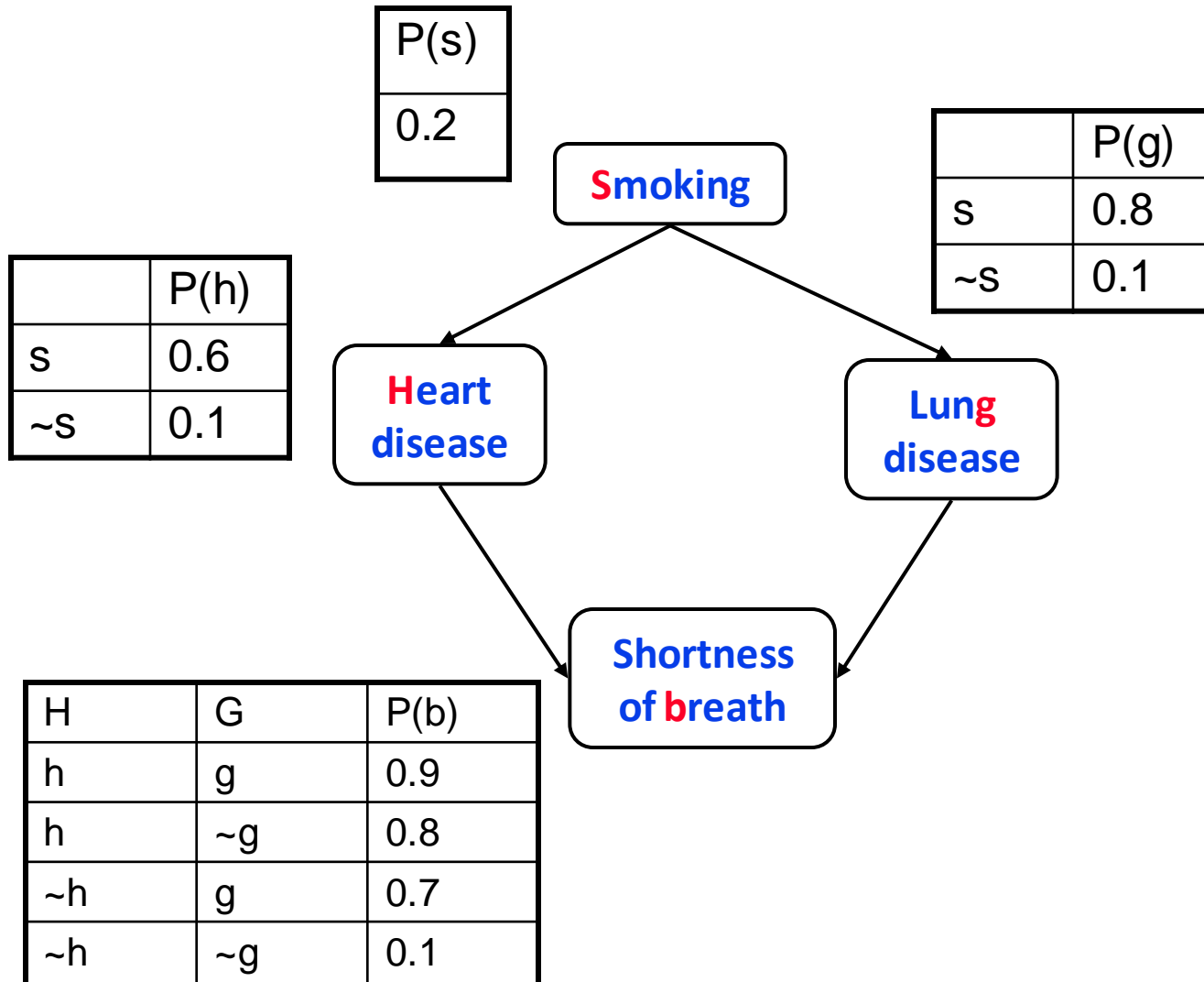

Example

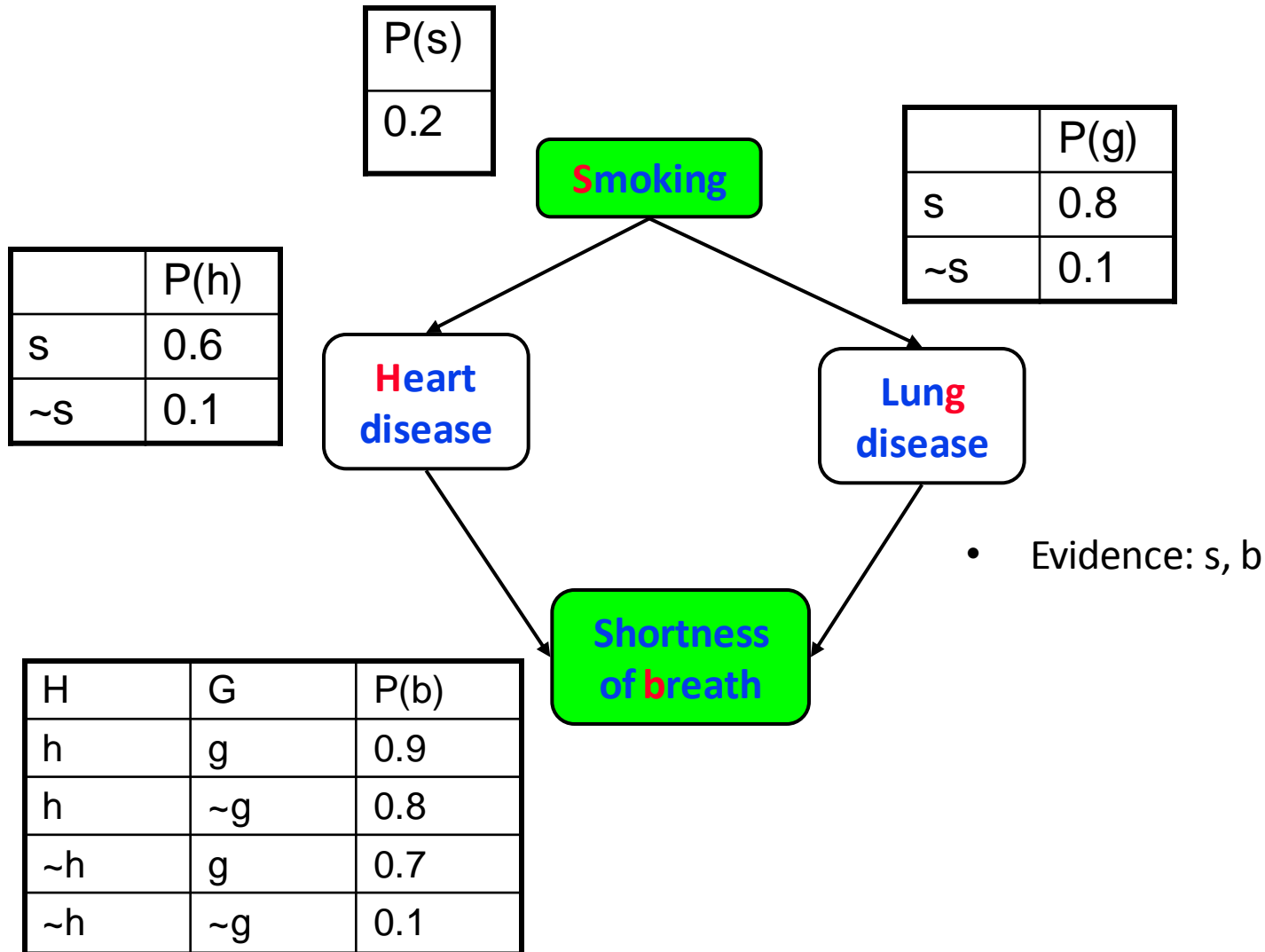

Example

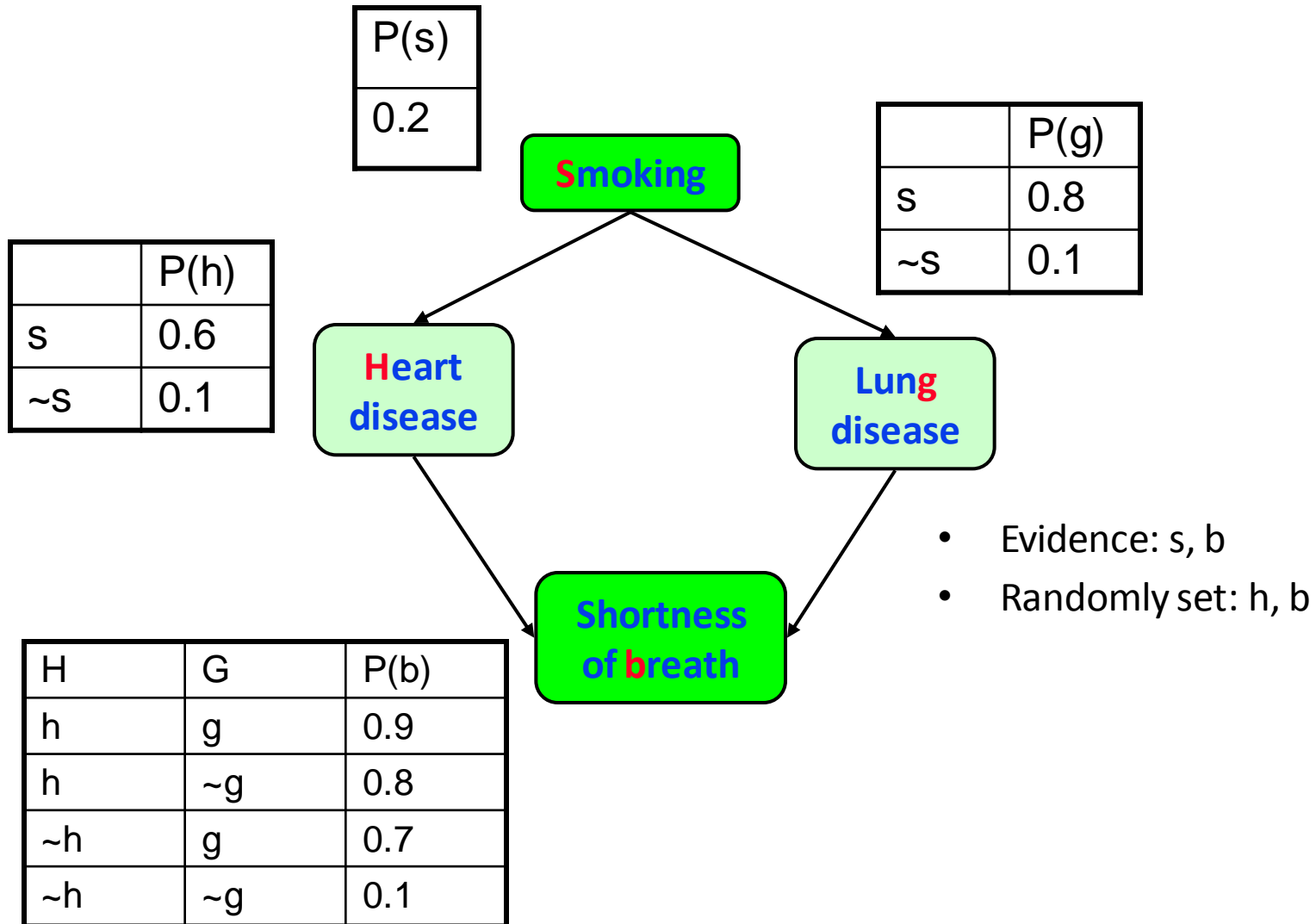

Example

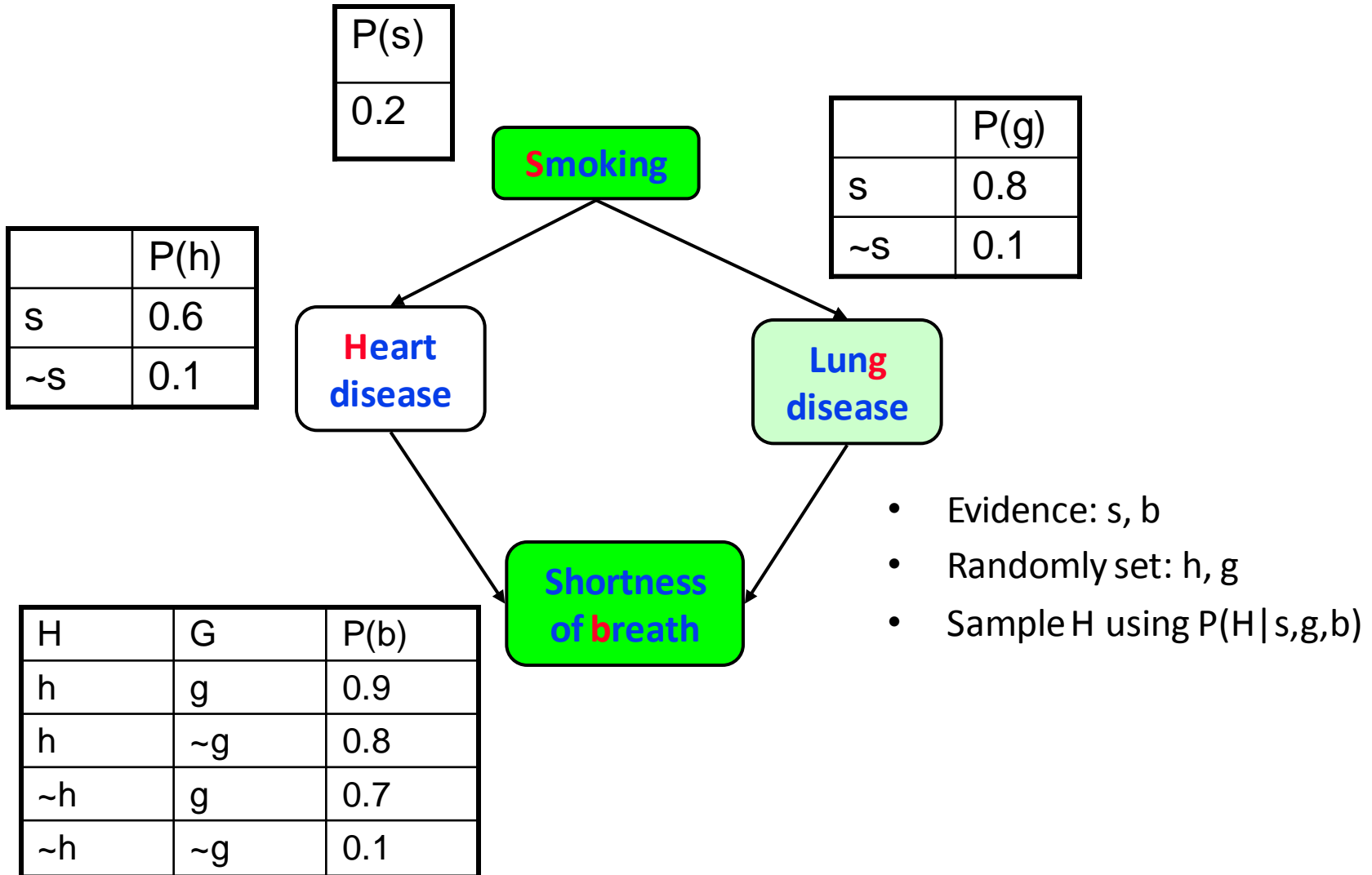

Example

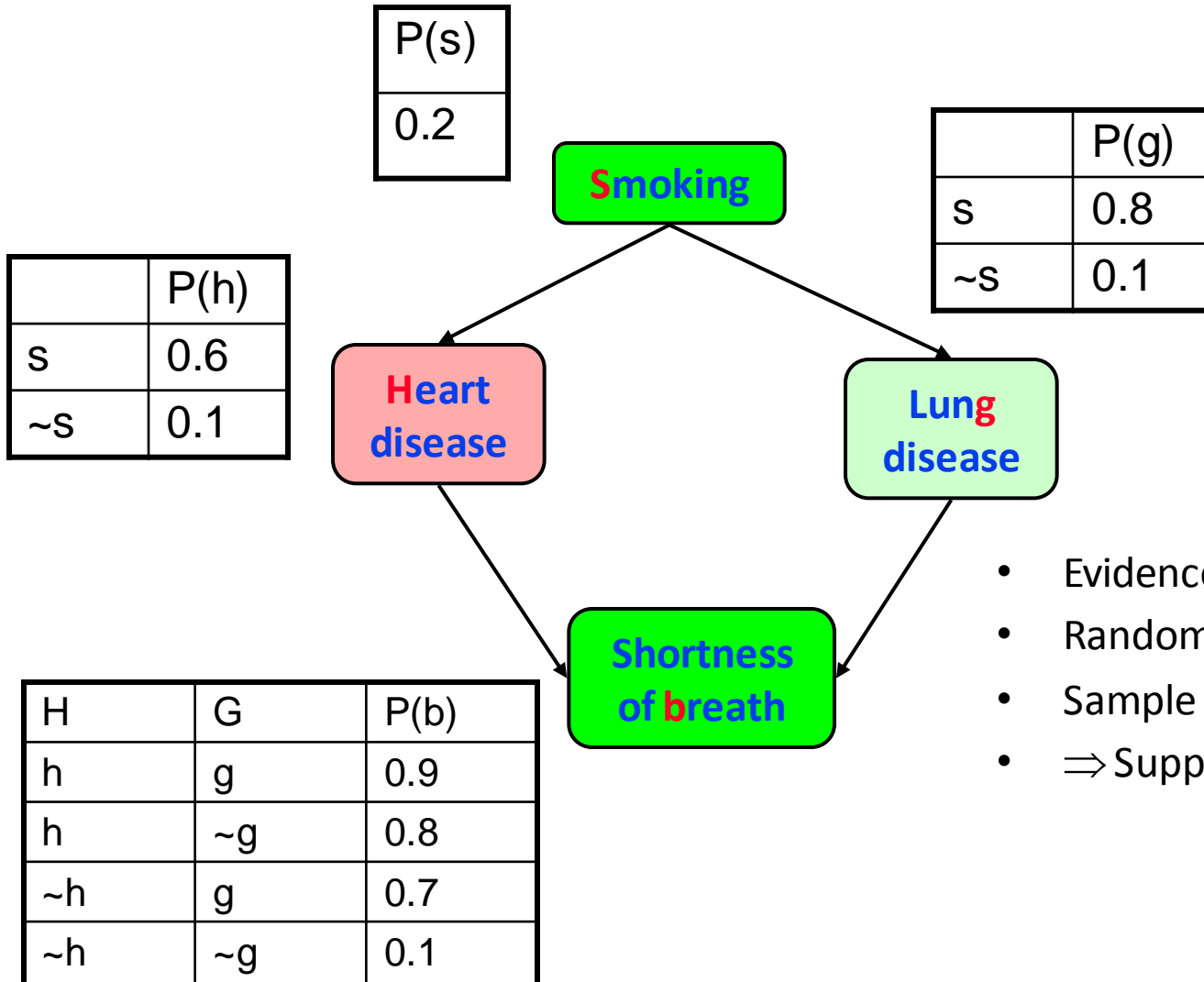

- Evidence: s, b
- Randomly set: $\sim h$, g
- Sample H using $P(H|s,g,b)$
- \Rightarrow Suppose result is $\sim h$

Example

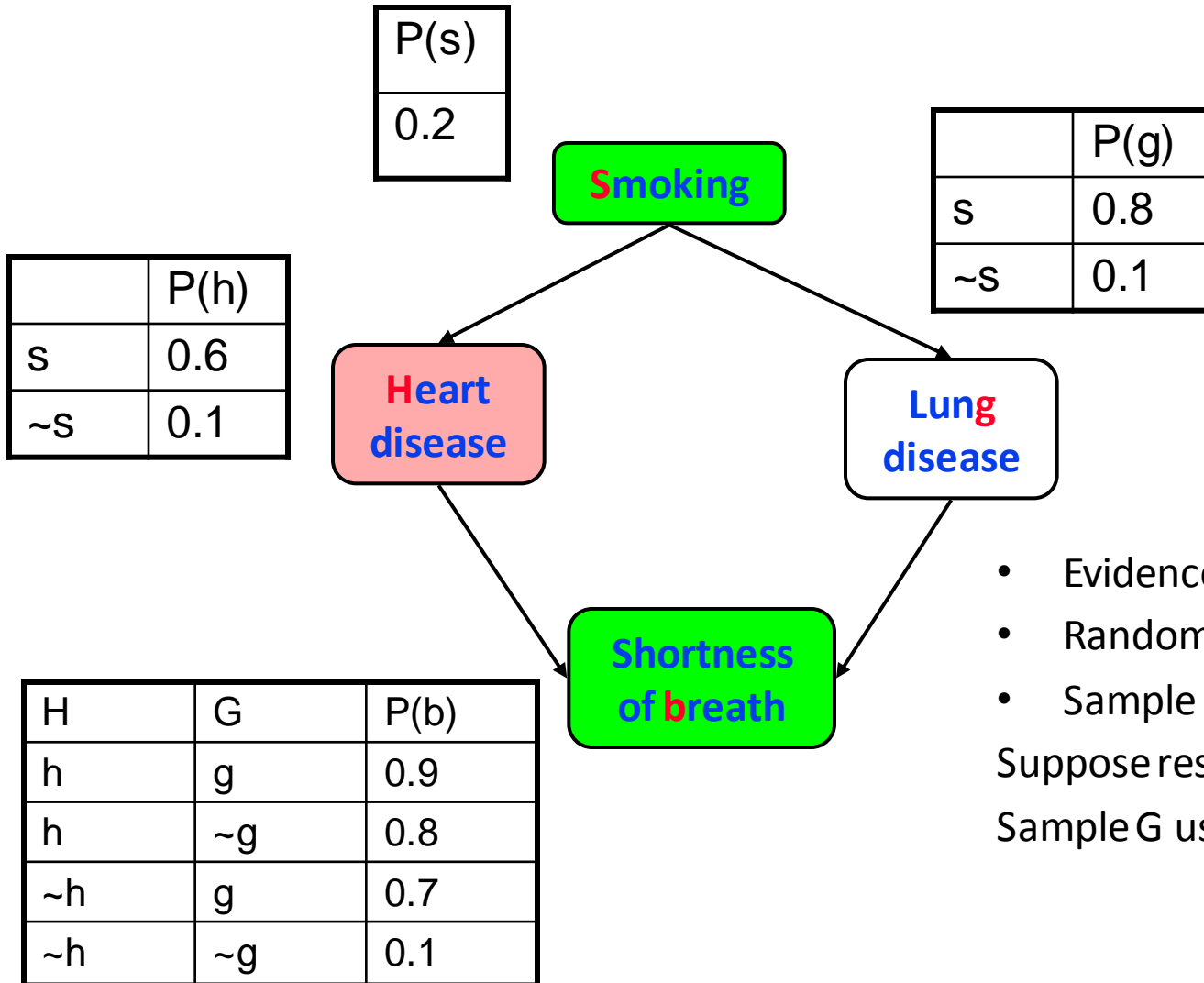

- Evidence: s, b
 - Randomly set: ~h, g
 - Sample H using $P(H|s,g,b)$
- Suppose result is ~h
- Sample G using $P(G|s,\sim h,b)$

Example

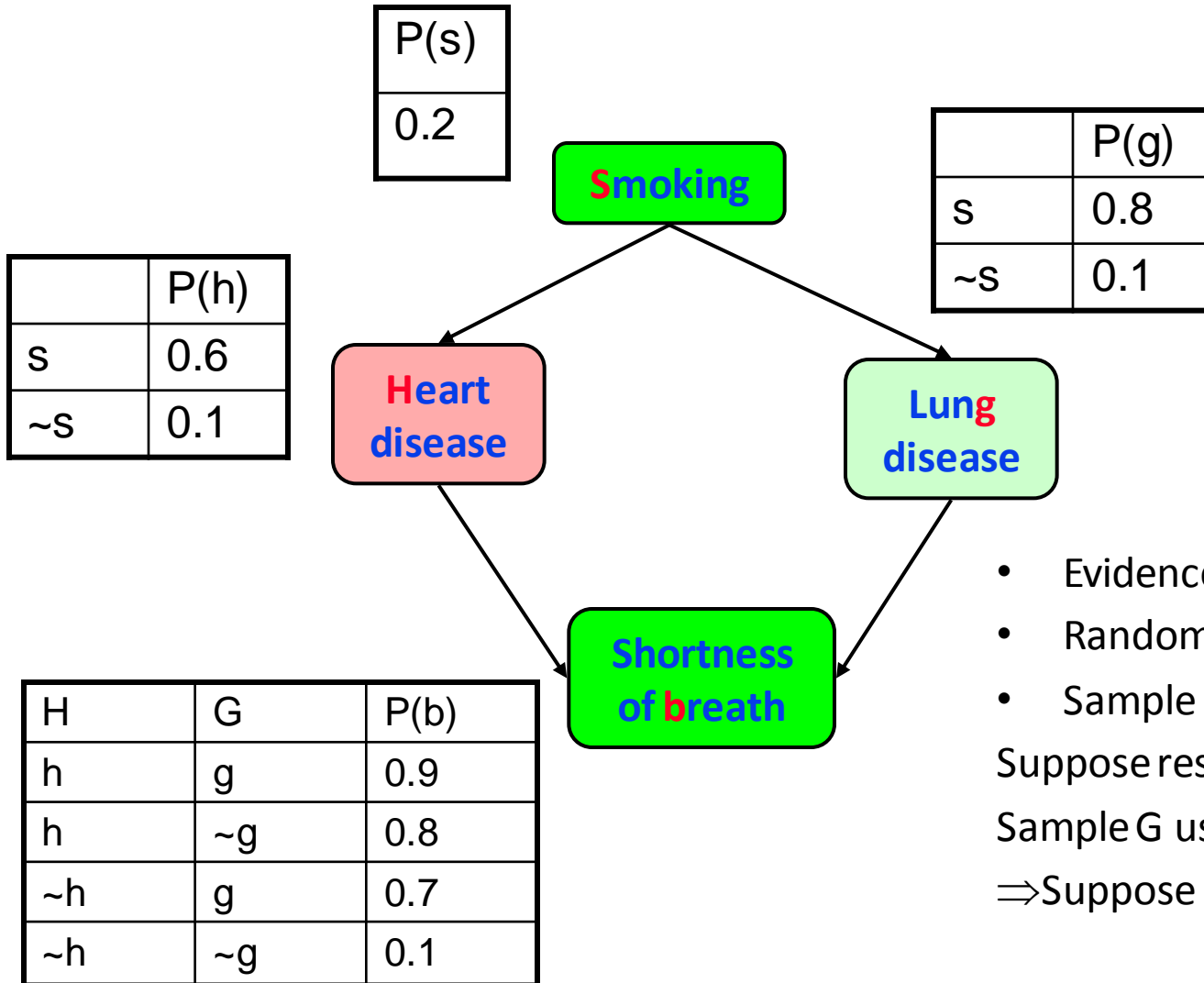

- Evidence: s, b
 - Randomly set: ~h, g
 - Sample H using $P(H|s,g,b)$
- Suppose result is ~h
- Sample G using $P(G|s,\sim h,b)$
- \Rightarrow Suppose result is g

Example

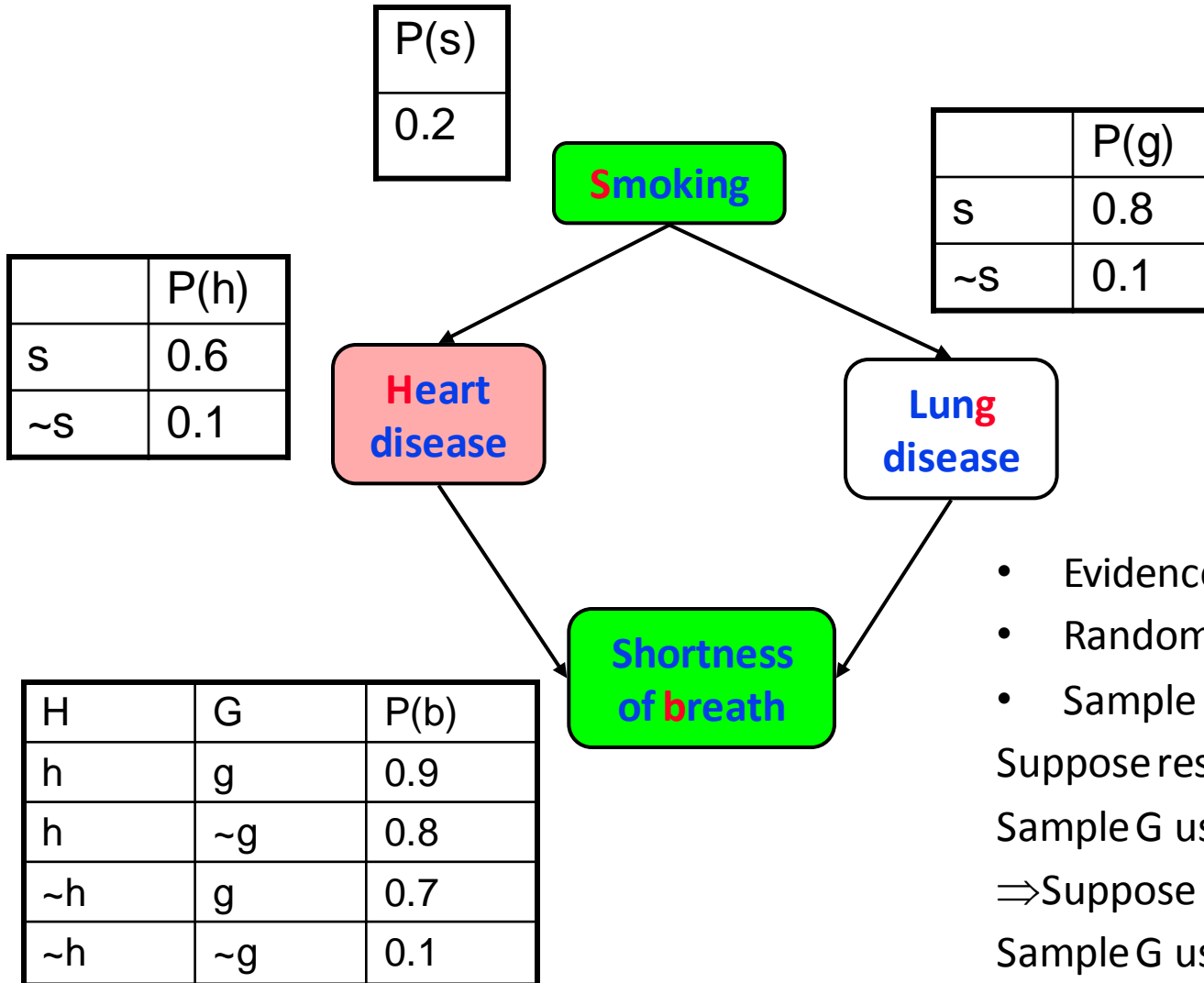

- Evidence: s, b
 - Randomly set: $\sim h$, g
 - Sample H using $P(H|s,g,b)$
- Suppose result is $\sim h$
- Sample G using $P(G|s,\sim h,b)$
- \Rightarrow Suppose result is g
- Sample G using $P(G|s,\sim h,b)$

Example

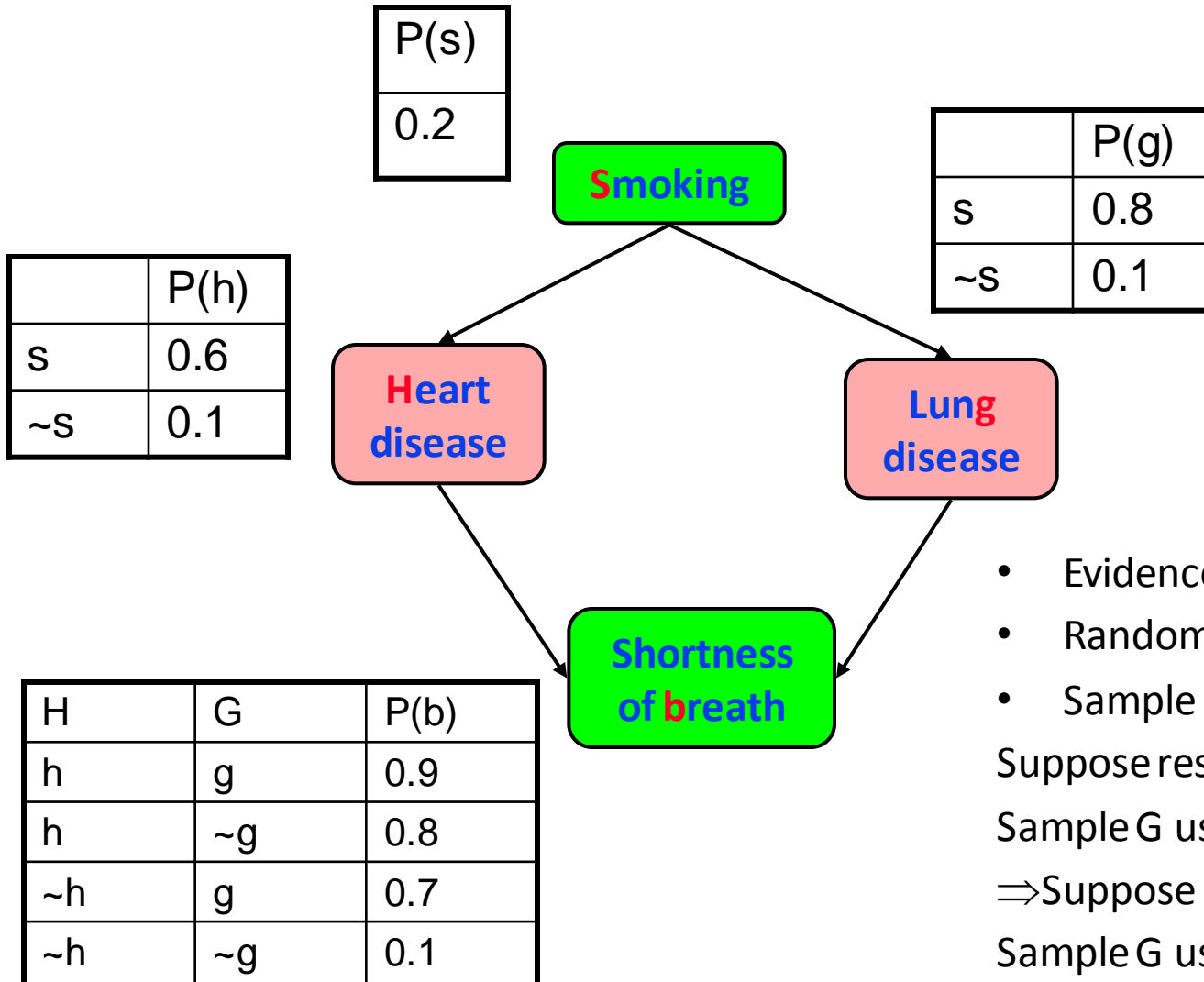

- Evidence: s, b
- Randomly set: ~h, g
- Sample H using $P(H|s,g,b)$

Suppose result is ~h

Sample G using $P(G|s,\sim h,b)$

⇒ Suppose result is g

Sample G using $P(G|s,\sim h,b)$

⇒ Suppose result is ~g

Gibbs MCMC Summary

$$P(X/E) = \frac{\text{number of samples with } X=x}{\text{total number of samples}}$$

- **Advantages:**
 - No samples are discarded
 - No problem with samples of low weight
 - Can be implemented very efficiently
 - 10K samples @ second
- **Disadvantages:**
 - Can get stuck if relationship between two variables is *deterministic*
 - Many variations have been devised to make MCMC more robust

Other inference methods

- Exact inference
 - Junction tree
- Approximate inference
 - Belief Propagation
 - Variational Methods