

Learning Deep Architectures for AI

By Yoshua Bengio

Commentary by Robert Gens

What's a Deep Architecture?

- ▶ Mindset or approach
- ▶ Not a specific system
- ▶ Some examples
- ▶ Just the tip of the iceberg

- Machine of simple processing nodes and wires

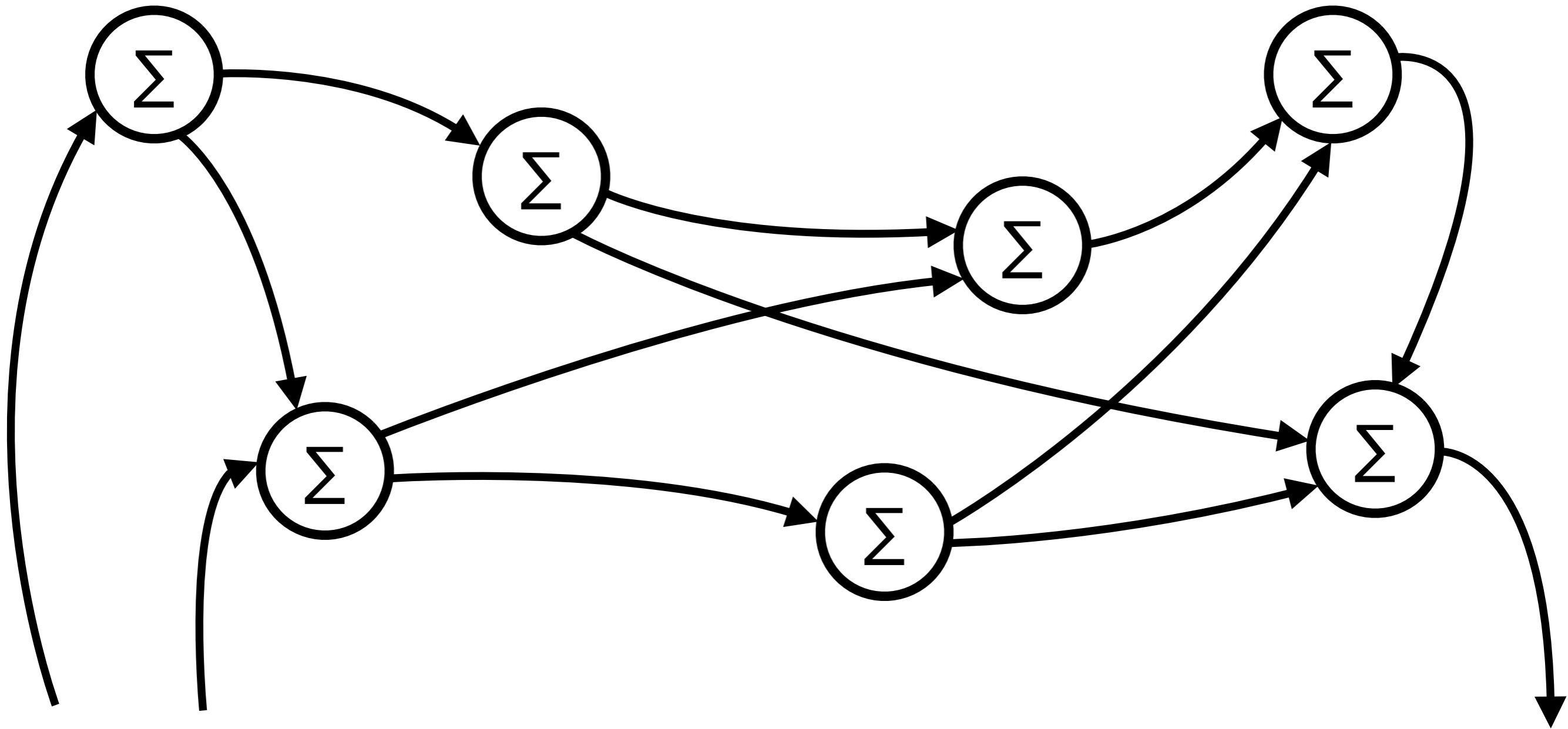

► Mindset or approach **What's a Deep**

- Information is represented in the wires

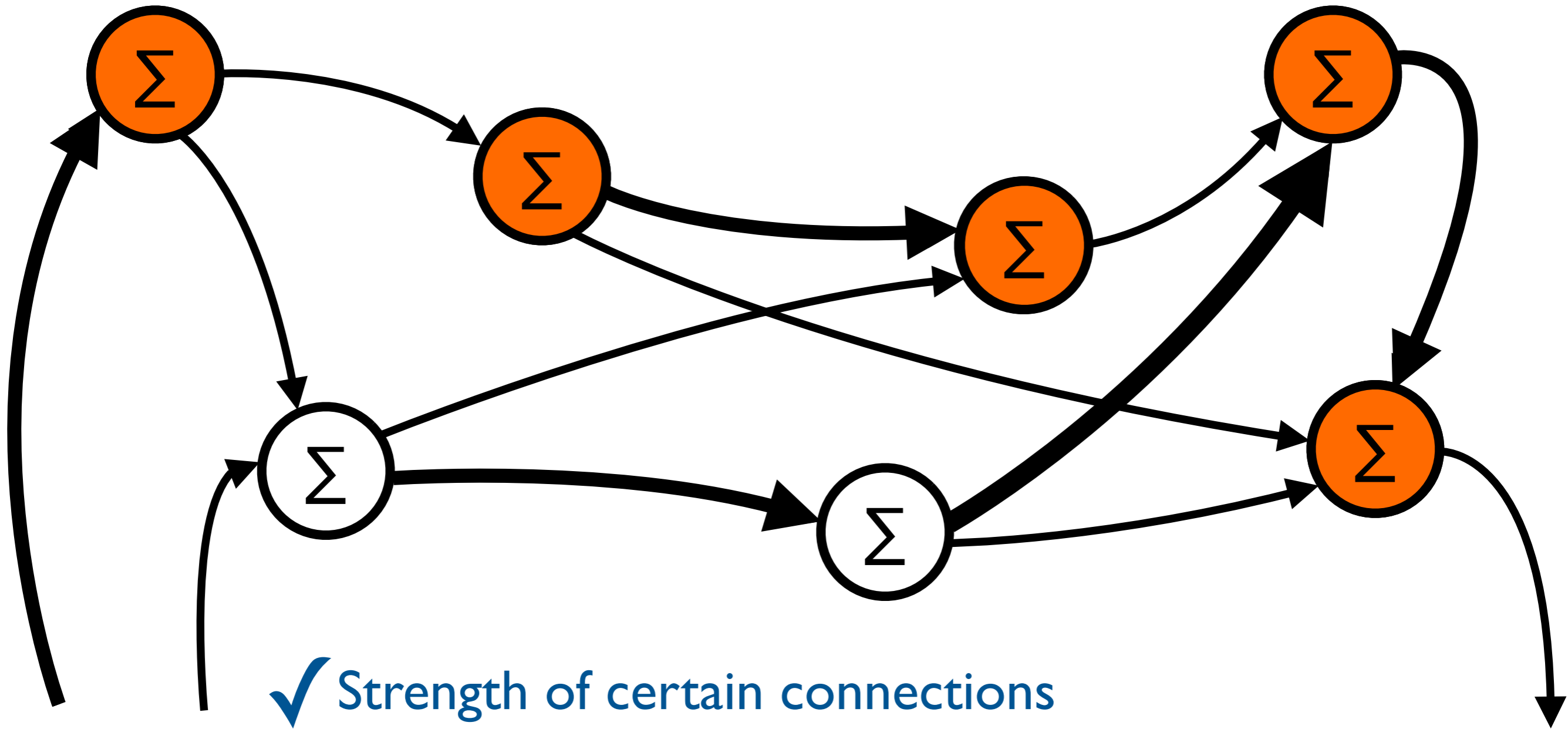

✓ Strength of certain connections

✓ Activity of the nodes and signals along wires in time

► Mindset or approach **What's a Deep**

- Nodes are typically arranged in layers

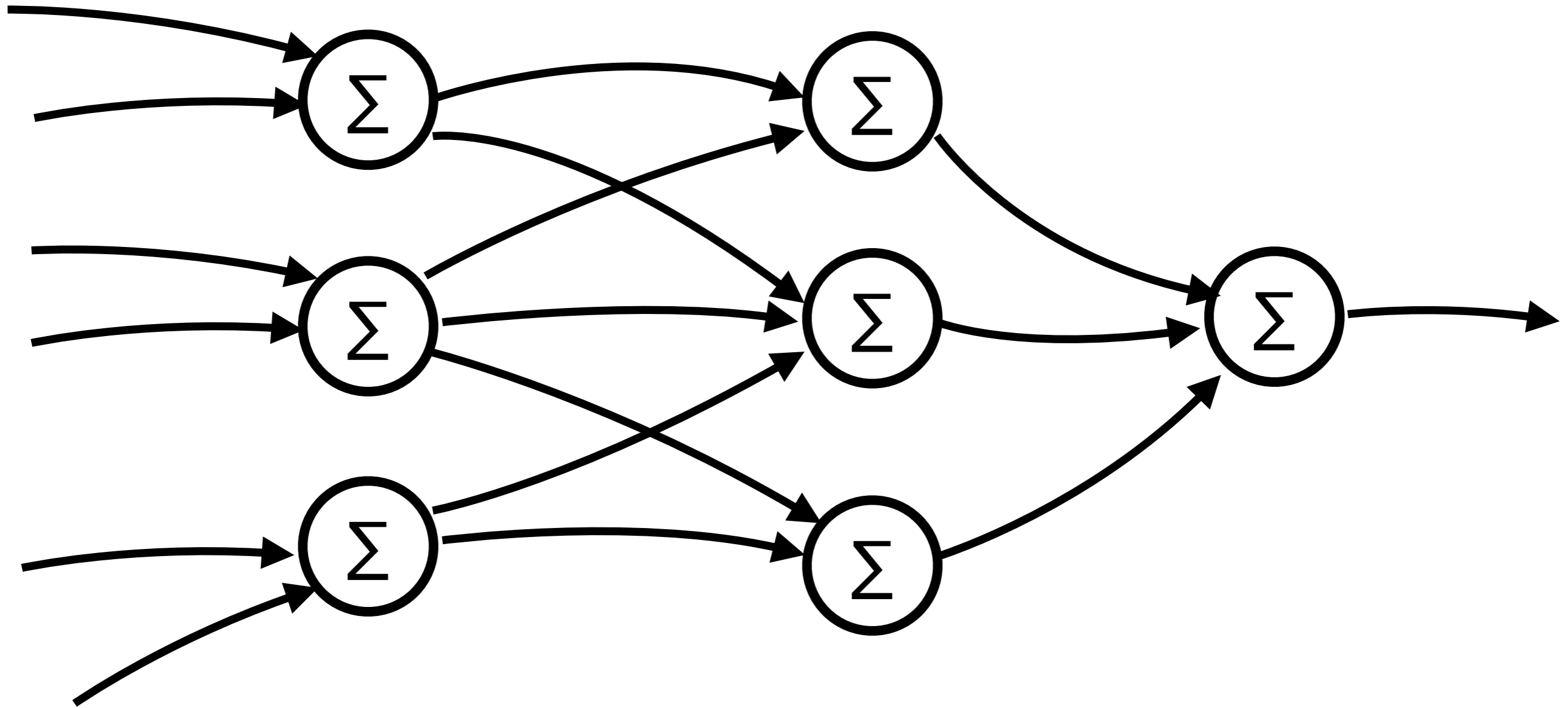

► Mindset or approach **What's a Deep**

- More layers is better

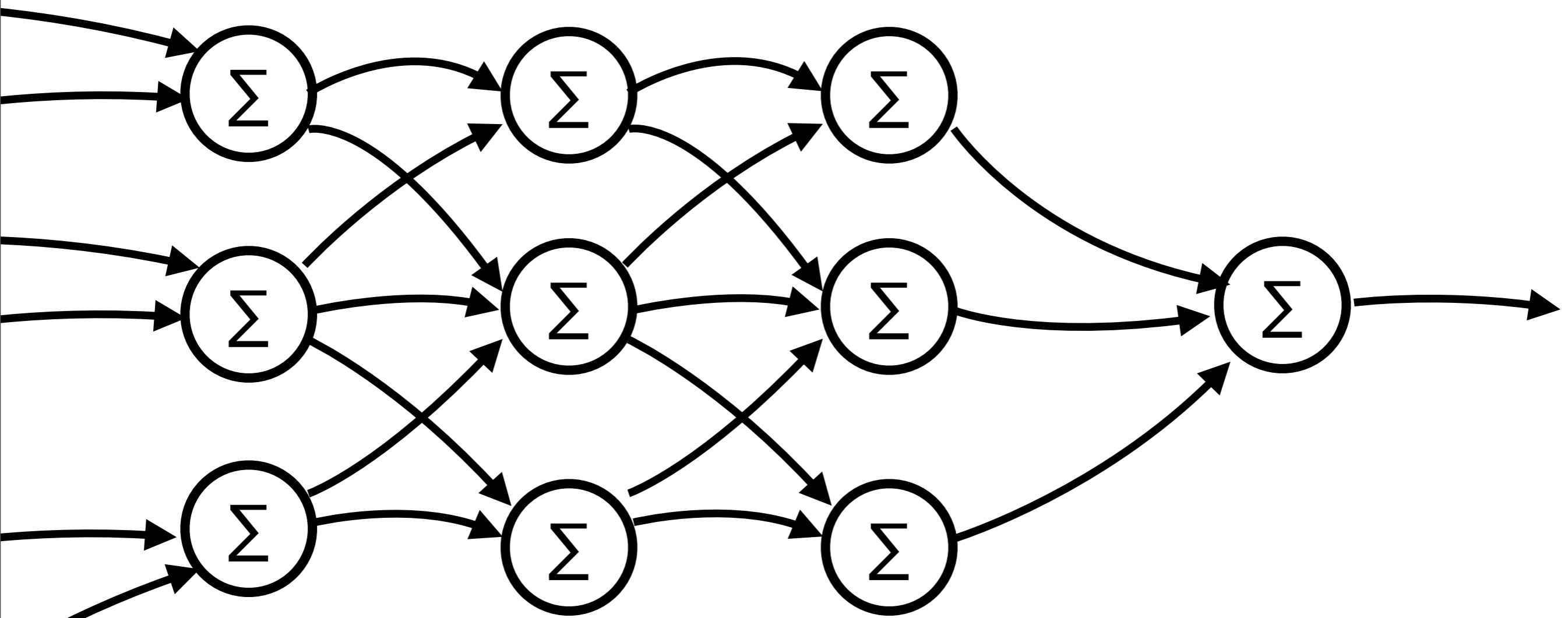

✓ More expressive in less space

✓ Integrate across space and time in less time

► Mindset or approach **What's a Deep**

What's a Deep Architecture?

- Machine of simple processing nodes and wires
- Information is represented in the wires
- Nodes are typically arranged in layers
- More layers is better

▶ Mindset or approach

Why should I care?

Speech

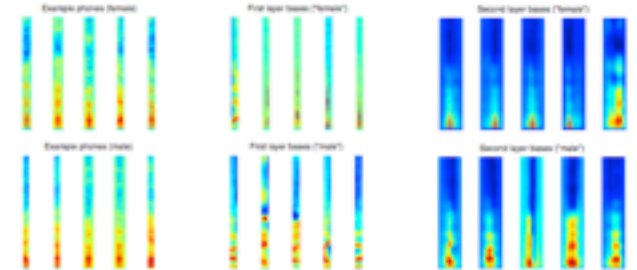
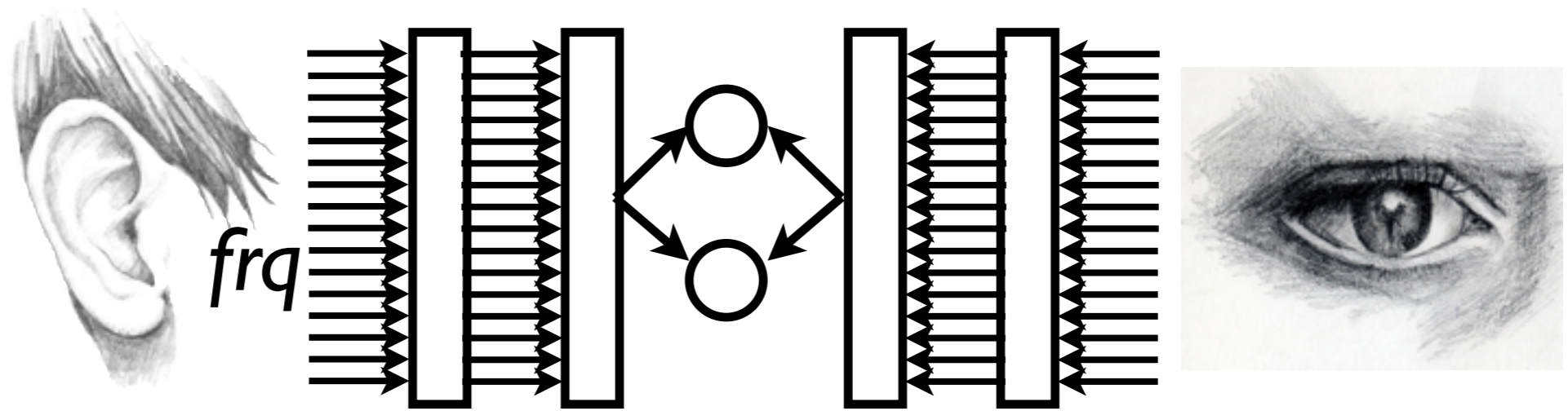

► Mindset or approach

Why should I care?

Speech

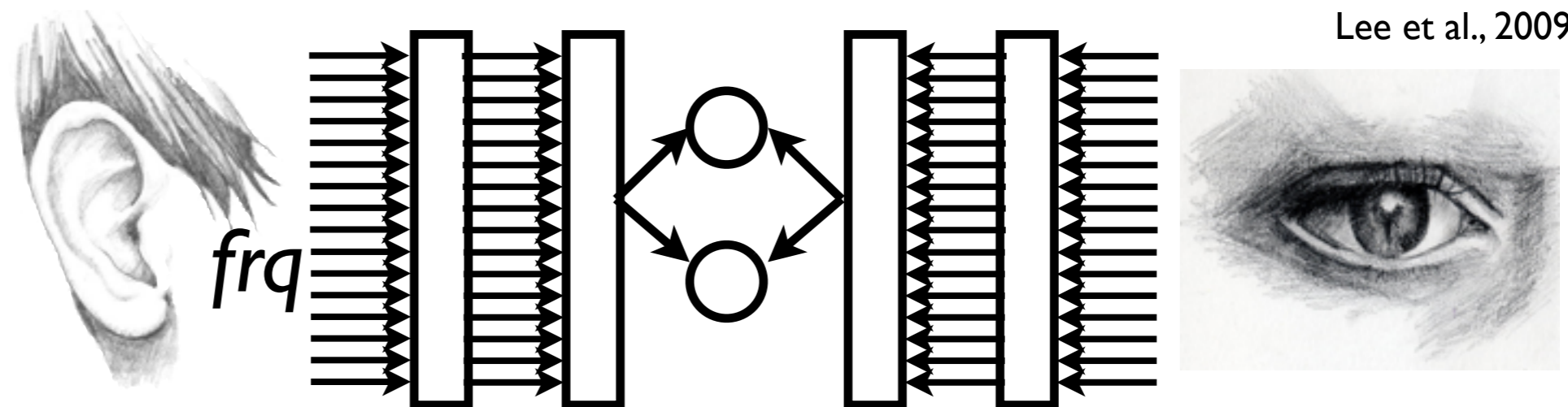
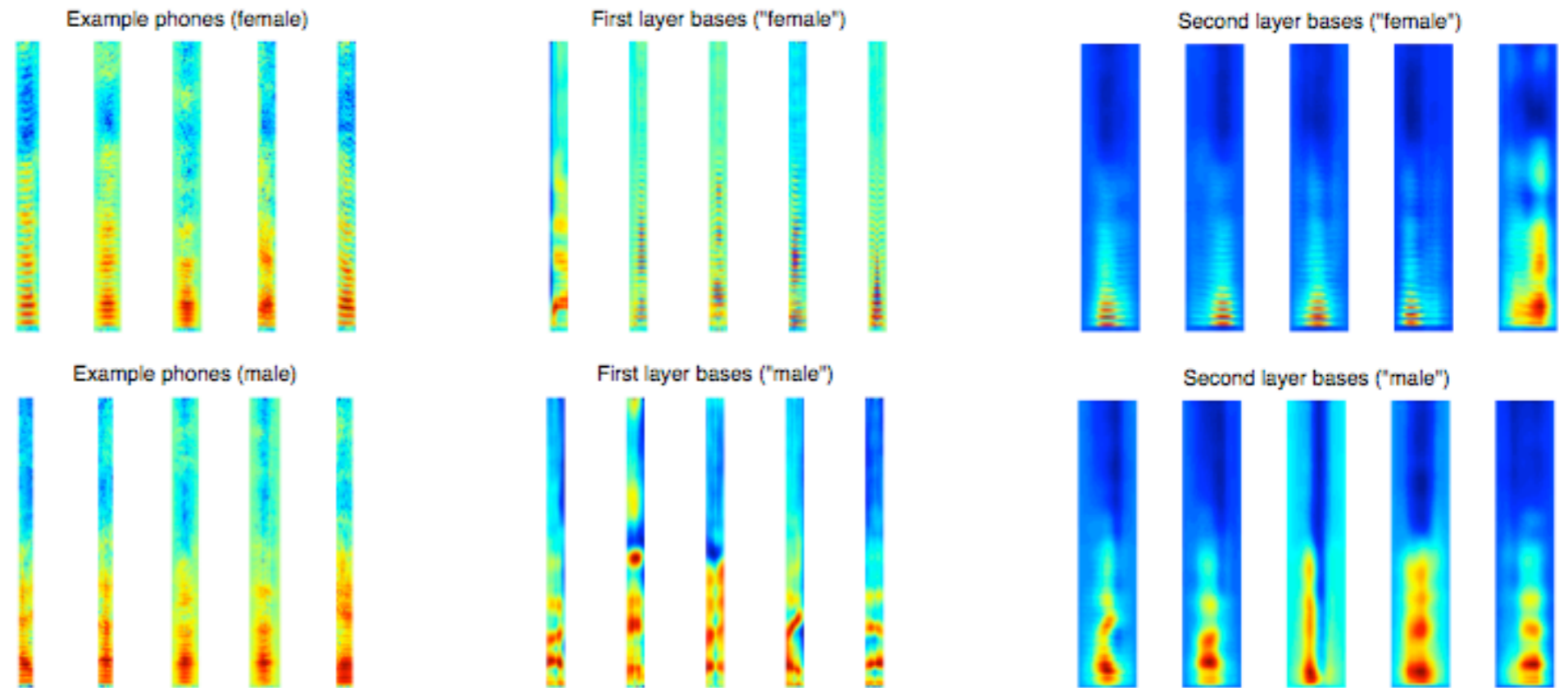

► Mindset or approach

Why should I care?

What caused the civil war?

Information Extraction

_____ caused the Civil War - 5 results
Slavery (4) **caused** the Civil War
Constitution (3) **caused** the Civil War
Trade Minister of Malaysia (2) **cause** Civil war
Lincoln (2) **caused** the Civil War
North and South (2) **caused** the Civil War

Flat

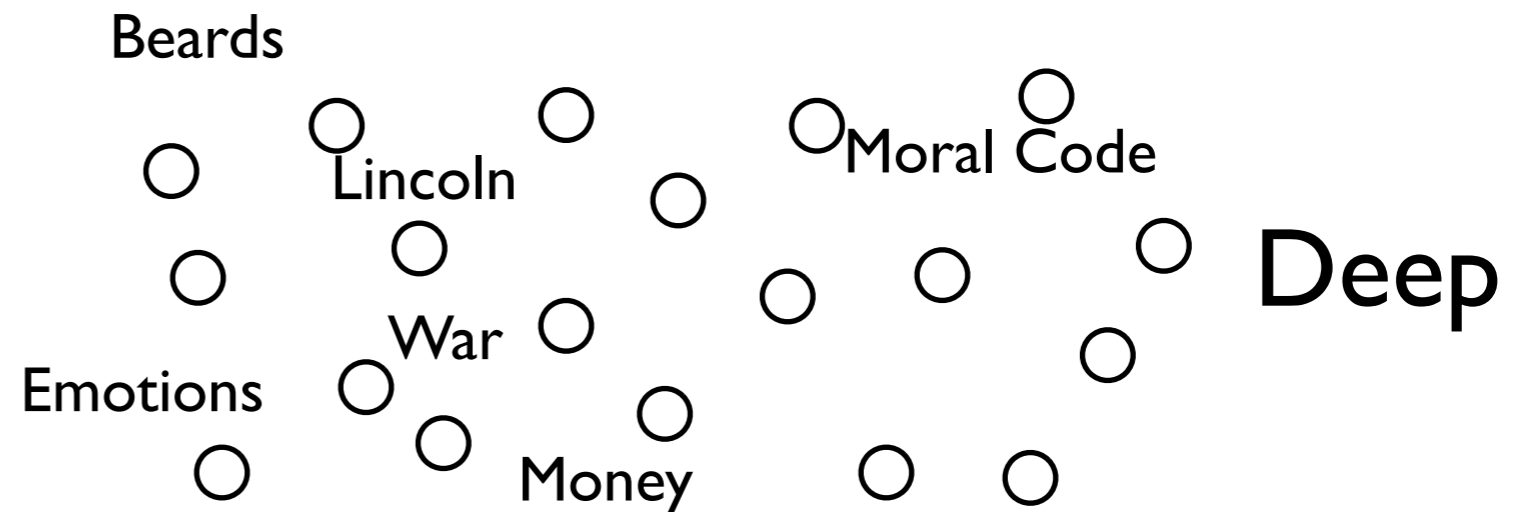

► Mindset or approach

Speech

Information Extraction

Why should I care?

Long Tail

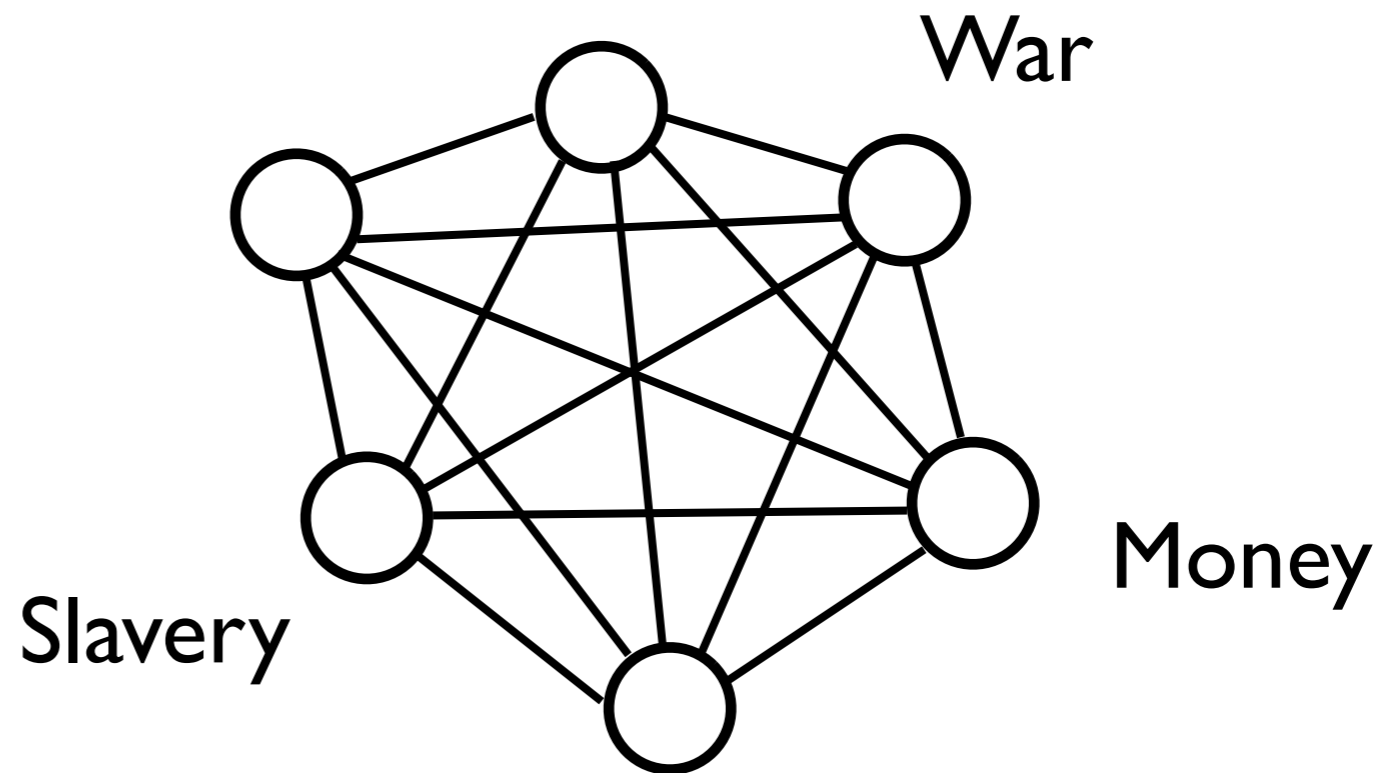

Flat can work here

► Mindset or approach

Speech

Information Extraction

Why should I care?

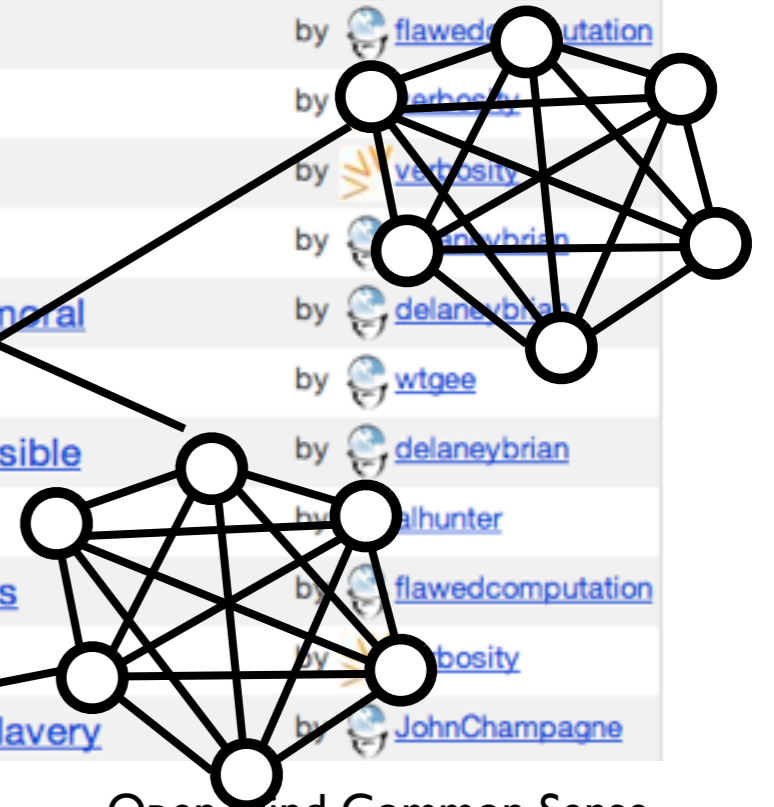
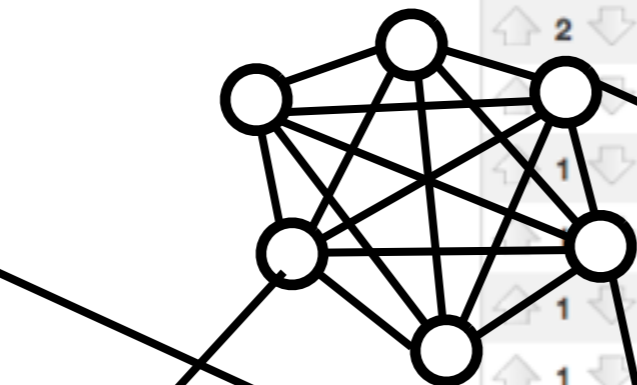
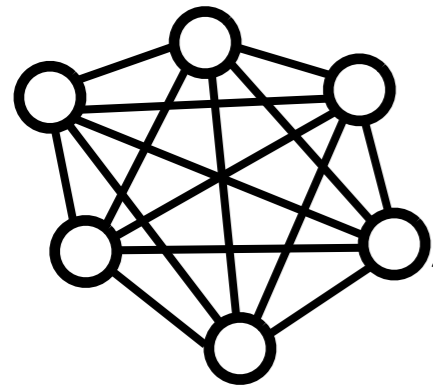

Long Tail

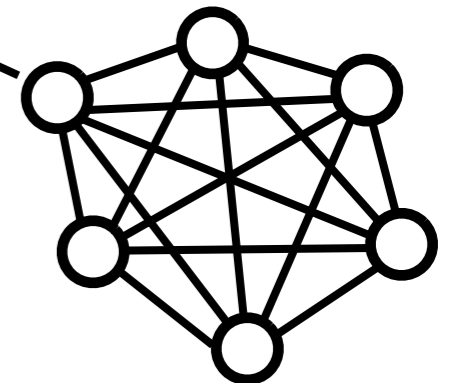
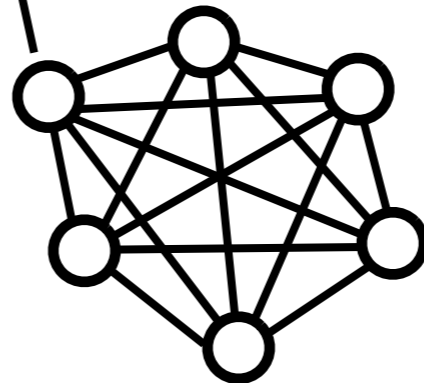
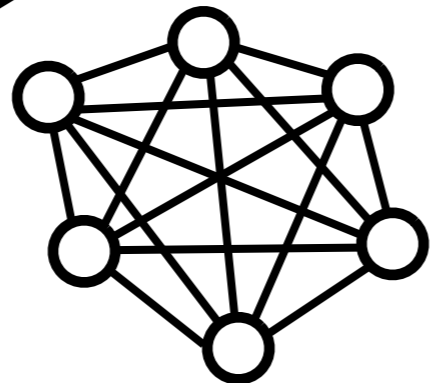
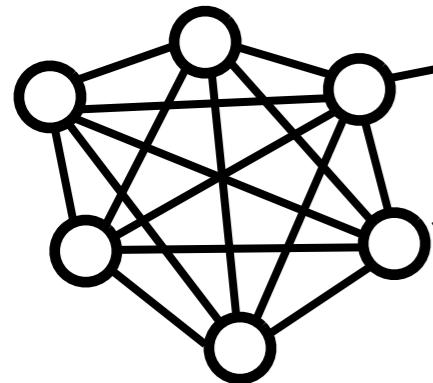
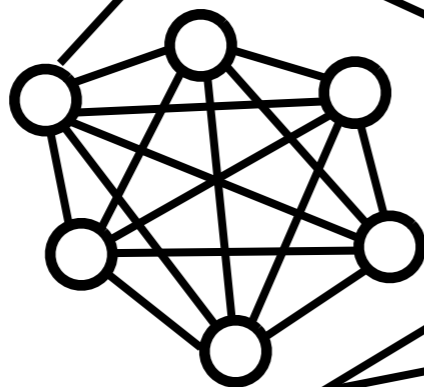

↑ 2 ↓	slavery is bad	by flawed computation
↑ 1 ↓	slavery is banned long	by verbosity
↑ 1 ↓	slavery is captivity	by delaneybrian
↑ 1 ↓	slavery is coercion and immoral	by delaneybrian
↑ 1 ↓	Slavery is now illegal	by wtgee
↑ 1 ↓	slavery is morally reprehensible	by delaneybrian
↑ 1 ↓	slavery has rewards	by delaneybrian
↑ 1 ↓	slavery is anit- human rights	by delaneybrian
↑ 1 ↓	slavery is master slaves	by verbosity
↑ 1 ↓	Using beings as things is slavery	by JohnChampagne

Open Mind Common Sense

► Mindset or approach

Speech

Information Extraction

Why should I care?

Long Tail

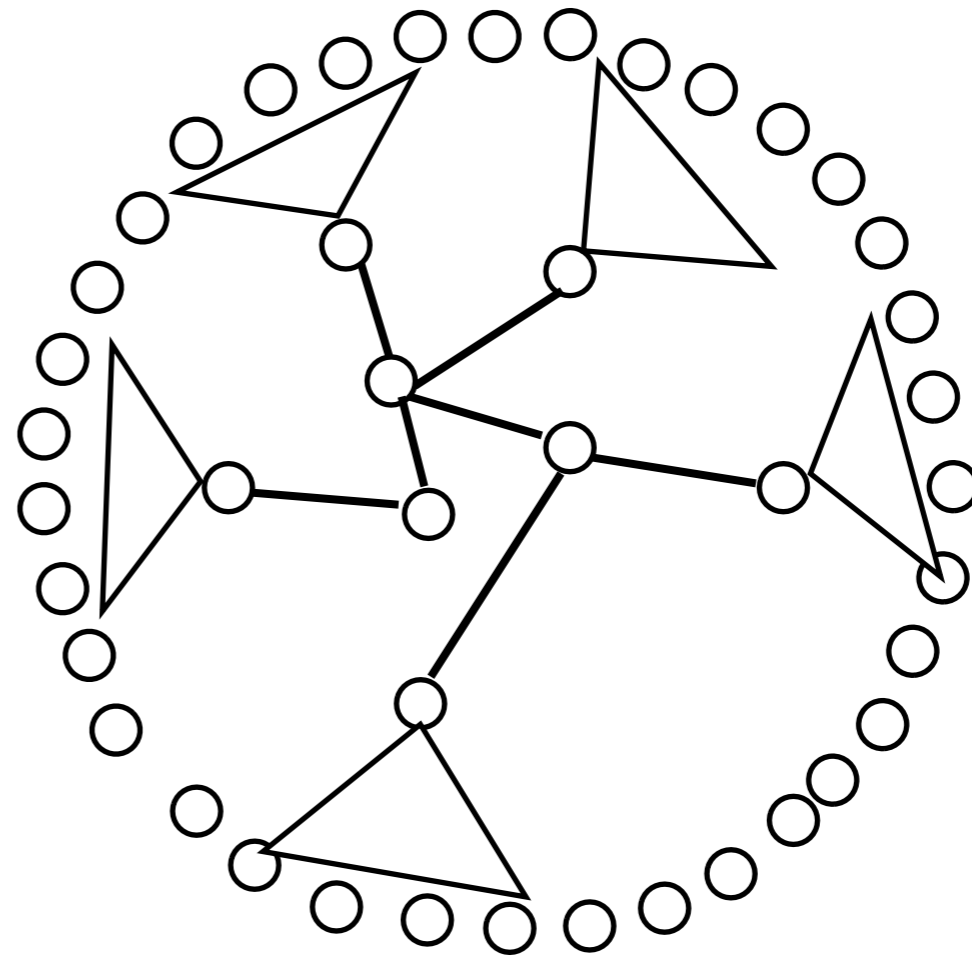

► Mindset or approach

Speech

Information Extraction

Long Tail

Why should I care?

Realtime

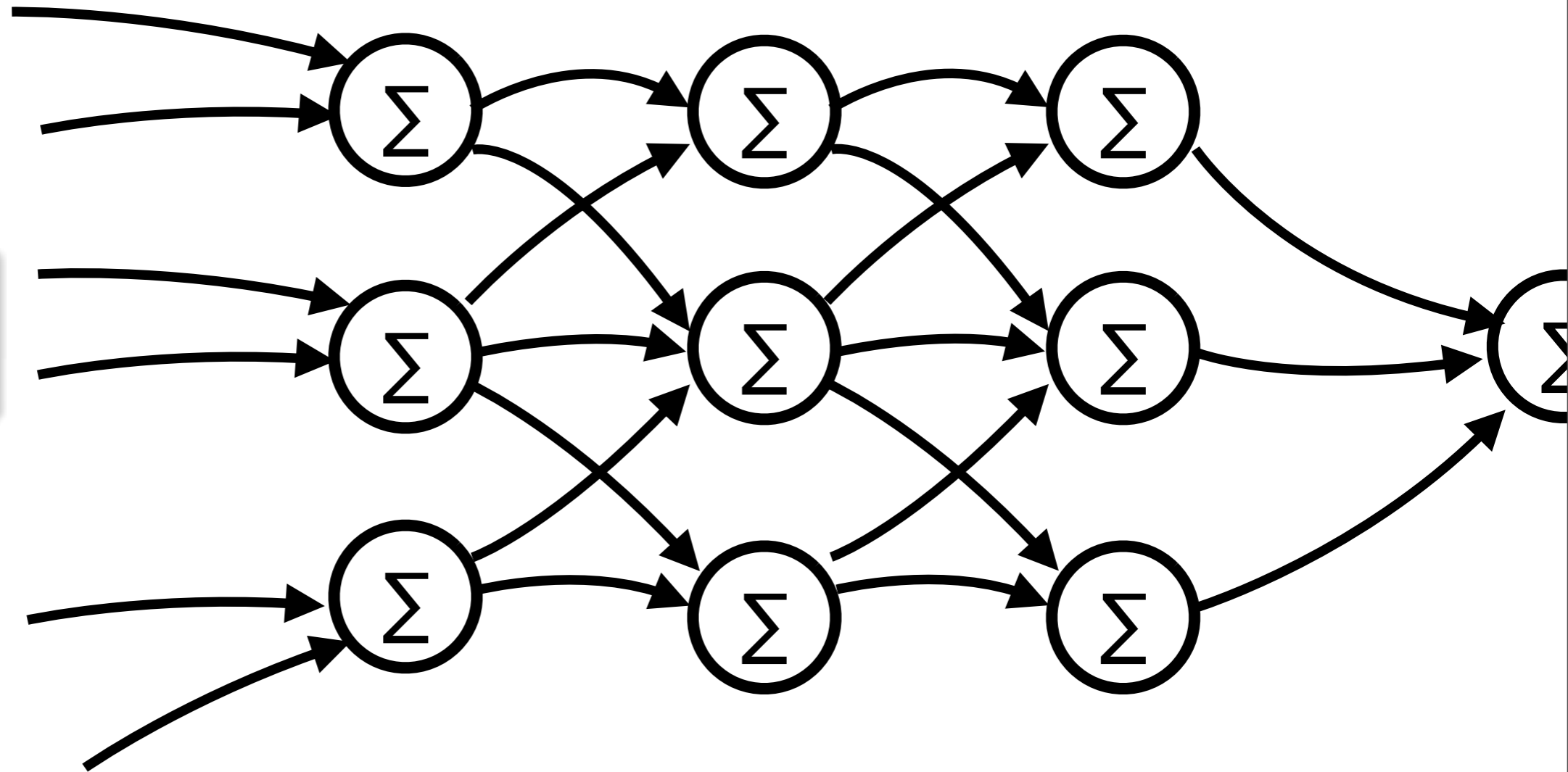

► Mindset or approach

Speech

Information Extraction

Long Tail

Realtime

Why should I care?

- Integrate multiple sources of information
- Limited space
- Constant time*

“Intelligence”

► Mindset or approach

Confusion

Convolutional
Neural Network

Deep Neural
Network

Convolutional
Deep Belief
Network

Deep Belief
Network

Recurrent
Temporal RBM

Restricted
Boltzmann
Machine

Neural
Networks

Boltzmann
Machines



Autoencoder

Deep Boltzmann
Machine

Time Delay
Neural Network

Sigmoid Belief
Network

Factored RBM

► Not a specific system

A Story



Pitts



McCulloch



Rosenblatt



Minsky



Papert



Ackley



Hinton



Sejnowski

1943

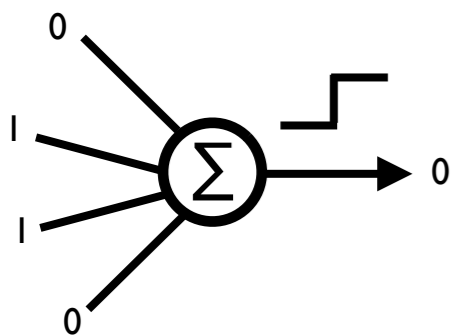

Artificial Neuron

1960

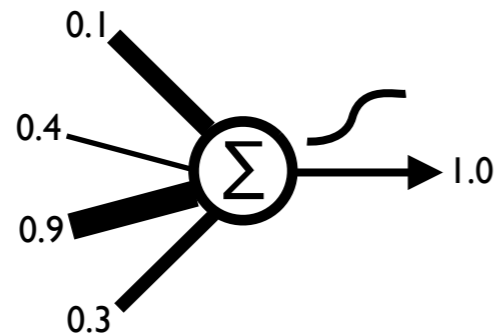

Perceptron

1969



Perceptrons

1985

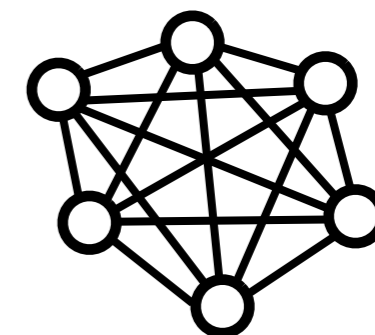

Boltzmann Machine

► Some examples



Smolensky



Hinton

Hinton et al.

1986

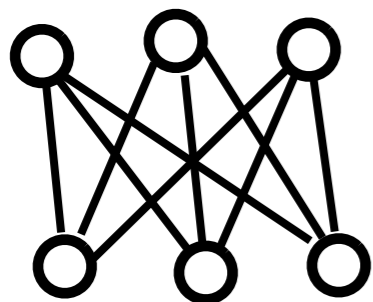

Harmoniums
(Restricted Boltzmann Machine)

2002

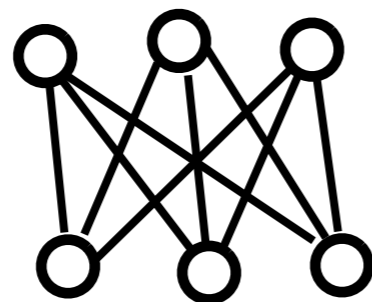

Contrastive
Divergence

2006

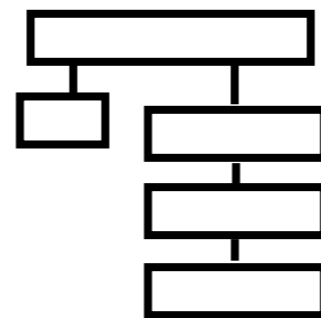

Deep Belief
Networks

► Some examples

To be continued

- Appropriate depth? Prove it.
- Supervised training \Rightarrow local minima? RBMs?
- How do we monitor progress? Measure results?
- How do we accommodate recurrent networks?
- Curriculum?
- The cortex and rest of the brain

▶ Just the tip of the iceberg